



SPEAR & JACKSON

**INSTRUCTION
MANUAL**

REAR ROLLER LAWN MOWER

1200W

LM1200



AFTERSALES SERVICE
01904 727505

MON-FRI 9am-5pm SAT/SUN 11am-4pm
www.spearandjackson-power.com



Important - Please read these instructions fully before operating or maintaining your lawnmower

These instructions contain important information that will help you get the best from your lawnmower, protecting your power tool investment.

THANK YOU!

Dear Customer,

Thank you for choosing a Spear and Jackson lawnmower.

Spear and Jackson was founded in 1760 in the city of Sheffield, which is world famous for the production of steel, cutlery and garden and hand tools.

Through continuous innovation and the use of new technologies and materials, Spear and Jackson has gained an enviable reputation as a supplier of reliable, high performance and high quality products designed to make your work in the garden as easy and enjoyable as possible.

FREE EXTENDED WARRANTY

We are so confident in the quality of our products we provide a 2 year guarantee on our garden power tools. We offer 12 month extended warranty for all registered garden power tools. Simply register your product within 28 days of purchase via www.spearandjackson-power.com to extend the standard manufacturer's warranty with an additional 12 months. After registering your product, your garden power tool will be covered for parts and labour for 3 years from the date of purchase, subject to the terms of the guarantee. If you do not wish to register your product within 28 days, your product is guaranteed for 2 year after date of purchase. It's important to retain your proof of purchase.

7 DAYS A WEEK TECHNICAL SUPPORT

We want you to get the best out of your products. Our easy-to-read instruction manual guides you with best practice use and maintenance tips. You can also visit www.spearandjackson-power.com for online help, general tips and useful videos about your garden product. However if you prefer to speak to one of technicians please call **01904 727505, Mon-Fri 9am-5pm and Sat/Sun 11am-4pm**, we can solve around 80% of questions directly over the phone.

We hope you enjoy your product and looking forward to any feedback, as this allows us to develop even better products for the future.

CONTENTS

Safety Information	04
Description of symbols	04
General safety	05
Personal safety	06
Operating safety	07
Maintenance and storage safety	09
Intended use	09
Box Content / Parts	10
Assembly	11
Unpacking	11
Fix the cable retain relief	11
Handle assembly	11
Fix the cable	12
Assemble the grass bag	12
Connection to the power supply	13
Operation	14
General operation	14
Setting cutting height	14
Connection to the power supply	15
Switching on	15
Switching off	15
Mowing direction	16
Grass bag full indicator	16
Maintenance	17
Technical Data	20
Troubleshooting	21
Guarantee	22
EC DECLARATION OF CONFORMITY	23

SAFETY INFORMATION

Please read these instructions fully before operating or maintaining your machine

DESCRIPTION OF SYMBOLS

The following warning symbols appear throughout this manual and indicate the appropriate safety measures you should take when operating and maintaining the lawnmower.



Before any use, refer to the corresponding paragraph in the present manual.



This symbol, before a safety comment, indicates a precaution, a warning or a danger. Ignoring this warning can lead to an accident for yourself or for others. To limit the risk of injury, fire, or electrocution always apply the recommendations indicated.



wear hearing protection



wear eye protection



wear protective gloves



Do not expose and operate the tool in rain.



Remove the plug from the mains immediately if cable is damaged or cut.



Objects thrown by the product could hit the user or other bystanders. Always ensure that other people and pets remain at a safe distance from the product when it is in operation. In general, children must not come near the area where the product is.



Beware of sharp blades. Remove plug from mains before maintenance or if cord is damaged.



Cutting device continues to rotate after the product is switched off. Wait until all components have completely stopped before touching the lawn mower.



Double insulation.



Keep the mains power cord away from cutting area.



Guaranteed sound power level value in 96 dB



The product complies with the applicable European directives and an evaluation method of conformity for these directives was done.



Recycle unwanted materials instead of disposing of them as waste. All tools, hoses and packaging should be sorted, taken to the local recycling centre and disposed of in an environmentally safe way.

SAFETY INFORMATION

Please read these instructions fully before operating or maintaining your machine

GENERAL SAFETY



IMPORTANT!

- Keep this instruction manual in a safe place for future reference.
- Read the instructions carefully. Be familiar with the controls and the proper use of the equipment.
- Never allow children or people unfamiliar with these instructions to use the pressure washer. Local regulations can restrict the age of the operator.
- Never use the machine while people, especially children, or pets are nearby. Keep in mind that the operator or user is responsible for accidents or hazards occurring to other people or their property.
- This appliance is not intended for use by persons (including children) with reduced physical, sensory or mental capabilities, or lack of experience and knowledge, unless they have been given supervision or instruction concerning use of the appliance by a person responsible for their safety.
- Don't use the appliance without reading the instruction sheet.
- Children should be supervised to ensure that they do not play with the appliance.

Work area safety

- Keep the work area clean and well lit. Cluttered or dark areas invite accidents.
- Do not operate power tools in explosive atmospheres, such as in the presence of flammable liquids, gases or dust. Power tools create sparks which may ignite the dust or fumes.

- Keep children and bystanders away while operating a power tool. Distractions can cause you to lose control.

Electrical safety

- Power tool plugs must match the outlet. Never modify the plug in any way. Do not use any adapter plugs with earthed (grounded) power tools. Unmodified plugs and matching outlets will reduce the risk of electric shock.
- Avoid body contact with earthed or grounded surfaces, such as pipes, radiators, ranges and refrigerators. There is an increased risk of electric shock if your body is earthed or grounded.
- Do not expose power tools to rain or wet conditions. Water entering a power tool will increase the risk of electric shock.
- Do not abuse the cord. Never use the cord for carrying, pulling or unplugging the power tool. Keep the cord away from heat, oil, sharp edges or moving parts. Damaged or entangled cords increase the risk of electric shock.
- When operating a power tool outdoors, use an extension cord suitable for outdoor use. Use of a cord suitable for outdoor use reduces the risk of electric shock.
- If operating a power tool in a damp location is unavoidable, use a residual current device (RCD) protected supply. Use of an RCD reduces the risk of electric shock. The maximum operating current of the RCD must be less than 30mA.
- The voltage indicated on the rating plate must correspond to the voltage of the power source.

SAFETY INFORMATION

Please read these instructions fully before operating or maintaining your machine

- Only use or replace power supply cables for this unit which correspond to the types indicated by the manufacturer. See the operating instructions for the order no. and types.
- Never touch the mains plug with wet hands.
- Do not run over, crush or pull the power supply cable or extension lead, otherwise it may be damaged. Protect the cable from heat, oil and sharp edges.
- The extension lead must have a cross section in accordance with the operating instructions and be protected against splashed water. The connection must not be in water.

Power tool use and care

- Do not force the power tool. Use the correct power tool for your application. The correct power tool will do the job better and more safely when operated at the rate for which it was designed.
- Do not use the power tool if the switch does not turn it on and off. Any power tool that cannot be controlled with the switch is dangerous and must be repaired.
- Disconnect the plug from the power source and/or the battery pack from the power tool before making any adjustments, changing accessories, or storing power tools. Such preventive safety measures reduce the risk of starting the power tool accidentally.
- Store idle power tools out of the reach of children and do not allow persons unfamiliar with the power tool or these instructions to operate the power tool. Power tools are dangerous in the hands of

untrained users.

- Maintain power tools. Check for misalignment or binding of moving parts, breakage of parts and any other condition that may affect the power tool's operation. If damaged, have the power tool repaired before use. Many accidents are caused by poorly maintained power tools.
- Keep cutting tools sharp and clean. Properly maintained cutting tools with sharp cutting edges are less likely to bind and are easier to control.
- Use the power tool, accessories and tool bits etc. in accordance with these instructions, taking into account the working conditions and the work to be performed. Use of the power tool for operations different from those intended could result in a hazardous situation.

PERSONAL SAFETY

- Stay alert, watch what you are doing and use common sense when operating the machine. Do not use the machine while you are tired or under the influence of drugs, alcohol or medication.
- Use personal protective equipment. Always wear eye protection. Protective equipment such as dust mask, non-skid safety shoes
- Stay alert, watch what you are doing and use common sense when operating the machine. Do not use the machine while you are tired or under the influence of drugs, alcohol or medication.

SAFETY INFORMATION

Please read these instructions fully before operating or maintaining your machine

- Use personal protective equipment. Always wear eye protection. Protective equipment such as dust mask, non-skid safety shoes or hearing protection used for appropriate conditions will reduce personal injuries.
- Prevent unintentional starting. Ensure the switch is in the off -position before connecting to power source and/or battery pack, picking up or carrying the tool.
- Do not carry the machine with your finger on the switch .
- Remove any adjusting key or wrench before turning the machine on. A wrench or a key left attached to a rotating part of the machine may result in personal injury.
- Do not overreach. Keep proper footing and balance at all times.
- Dress properly. Do not wear loose clothing or jewellery. Keep your hair, clothing and gloves away from moving parts. Loose clothes, jewellery or long hair can be caught in moving parts.
- If devices are provided for the connection of dust extraction and collection facilities, ensure these are connected and properly used. Use of dust collection can reduce dust-related hazards.
- Warning! Switch off, remove plug from mains before adjusting, cleaning or if cable is cut, damaged or entangled.
- The blades continue to rotate for a few seconds after the machine is switched off.
- The machine is double insulated for safety and requires no earth connection.
- The operating voltage is 230V AC, 50Hz (for non-EU countries 220V, 240V as

applicable). If you want to use an extension cable when operating your product, only the following cable dimensions should be used:

- 1.0mm²: max. length 40m
- 1.5 mm²: max. length 60m
- 2.5 mm²: max. length 100m
- Note: If an extension cable is used it must be earthed and connected through the plug to the earth cable of your supply network in accordance with prescribed safety regulations.
- If in doubt contact a qualified electrician or the nearest Cobra Service Centre.
- WARNING! Inadequate extension cables can be dangerous. Extension cable, plug and socket must be of watertight construction and intended for outdoor use.
- It is recommended for increased electrical safety to use a Residual Current Device (RCD) with a tripping current of not more than 30mA. Always check your RCD every time you use it.

OPERATING SAFETY

Training

- Read the instructions carefully. Be familiar with the controls and the proper use of the product.
- Never allow people unfamiliar with these instructions or children to use the product.

SAFETY INFORMATION

Please read these instructions fully before operating or maintaining your machine

Local regulations can restrict the age of the operator.

- Keep in mind that the operator or user is responsible for accidents or hazards occurring to other people or their property.

Preparation

- Never operate the product while people, especially children, or pets are nearby.
- Wear eye, ear and mouth protection at all times while operating the product

Operation

- Use the product only in daylight or good artificial light.
- Never operate the product with damaged guards or shields or without guards or shields in place.
- Keep hands and feet away from the cutting attachment at all times and especially when switching on the motor.
- Before use check the controls and correct operation of the product.
- Before using the product or after any impact, check for signs of wear or damage and repair as necessary.
- Always disconnect the product from the power supply (i.e. remove the plug from the power supply or the battery pack)
 - whenever leaving the product unattended;
 - before clearing a blockage;
 - before checking, cleaning or working on the product
 - after striking a foreign object;

- whenever the product starts vibrating abnormally.
- Take care against injury to feet and hands from the cutting attachment.
- Always ensure that the air vents are kept clear of debris.
- Never use replacement parts or accessories not provided or recommended by the manufacturer.
- The product should be supplied via a residual current device (RCD) with a tripping current of not more than 30 mA.
- Avoid using the product in bad weather conditions especially when there is a risk of lightning.
- Position the cord so that it will not be caught by the cutting attachment during operation.
- Disconnect from the power supply when the cord becomes damaged or tangled.
- If the cord becomes damaged during use, disconnect the cord from the supply immediately. **DO NOT TOUCH THE CORD BEFORE DISCONNECTING THE SUPPLY.**
- Do not use the product if the cord is damaged or worn.
- Warning! The cutting elements continue to move after the product is switched off.
- Keep the extension cord away from the blades at all times.
- Only use an extension cord with conductors of not less than 1.5mm² or 2.0mm² and:
 - if rubber insulated, ordinary tough rubber sheathed flexible cord (code designation 60245 IEC 53);

SAFETY INFORMATION

Please read these instructions fully before operating or maintaining your machine

INTENDED USE

This lawnmower is designed for domestic use only:

- This electric lawnmower is intended for bagging, mulching and discharging lawns in domestic and hobby gardens.
- This product is not to be used in wet weather conditions and may not be used to mow dry, wet or unusually high grass, e. g. pasture grass or for shredding leaves.
- This product is intended for private domestic use only, not for any commercial trade use. It must not be used for any purposes other than those described.

Any use of the machine that deviates from its intended use and is not included in these.

- if polyvinyl chloride insulated, ordinary polyvinyl chloride sheathed flexible cord (code designation 60227 IEC 53).
- Do not expose the product to rain. instructions is considered unauthorized use and relieves the manufacturer from his or her legal liability.

MAINTENANCE AND STORAGE SAFETY

- Disconnect the product from the power supply (i.e. remove the plug from the power supply or the battery pack) and check for damage after use.
- Disconnect the product from the power supply (i.e. remove the plug from the power supply or the battery pack) before carrying out maintenance or cleaning work.
- Use only the manufacturer's recommended replacement parts and accessories.
- Inspect and maintain the product regularly. Have the product repaired only by an authorised service centre or similar qualified specialist.
- When not in use, store the product out of the reach of children.

Service

- Have your power tools serviced by a qualified repair person using only identical replacement parts. This will ensure that the safety of the power tool is maintained.

BOX CONTENT

PARTS

- | | |
|------------------------|---------------------------|
| 1 Switch box | 7 Grass bag |
| 2 Switch bar | 8 Lower handle |
| 3 Upper handle | 9 Height adjusting handle |
| 4 Middle handle | 10 Deck |
| 5 Quick release lock | 11 Cable retain relief |
| 6 Full grass indicator | 12 Extension cord |

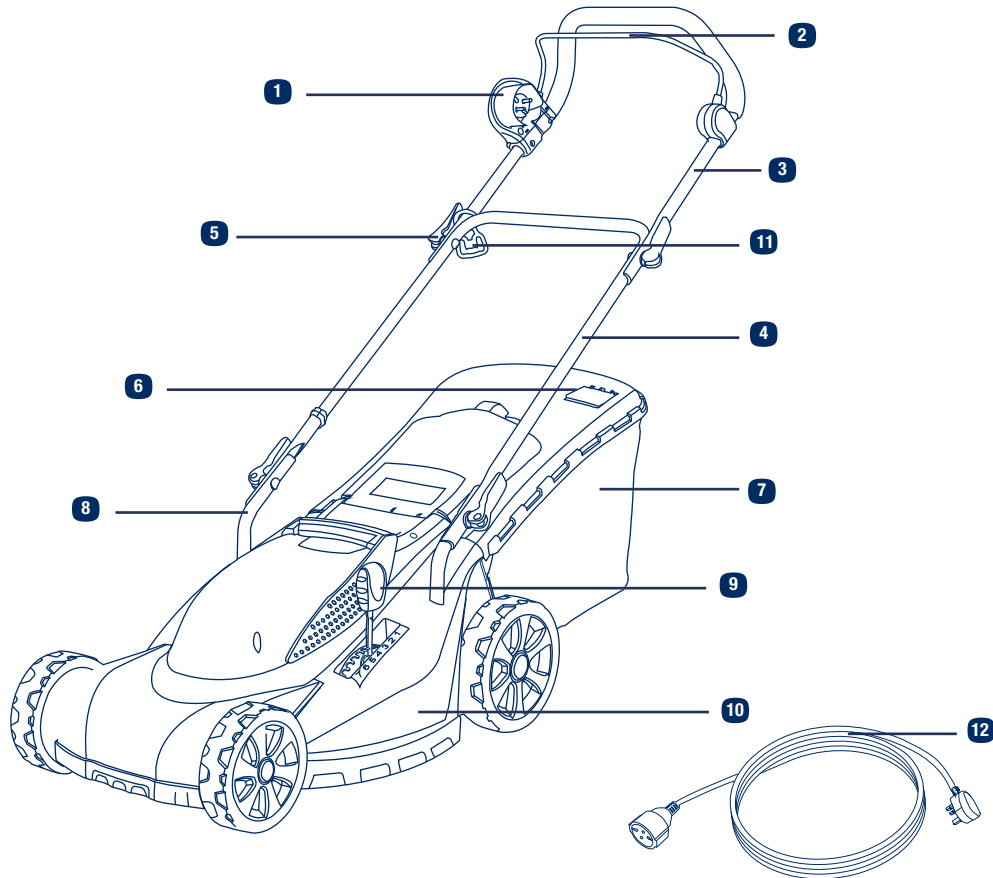

ASSEMBLY

1 Unpacking

- Unpack all parts and lay them on a flat, stable surface.
- Remove all packing materials and shipping devices if applicable.
- Make sure the delivery contents are complete and free of any damage. If you find that parts are missing or show damage do not use the product but contact your dealer. Using an incomplete or damaged product represents a hazard to people and property.
- Ensure that you have all the accessories and tools needed for assembly and operation. This also includes suitable personal protective equipment.

2 Fix the cable retain relief

- Lead the middle handle through the hole in the cable retain relief, and hook on it.

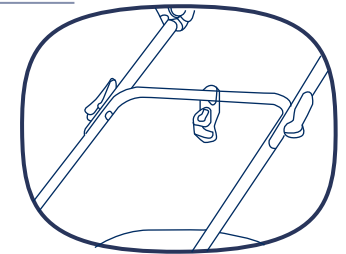

3 Handle assembly

- Fit the upper handle, middle handle and lower handle together with the quick release lock system. you can rotate release lock to adjust the tightness of lock.

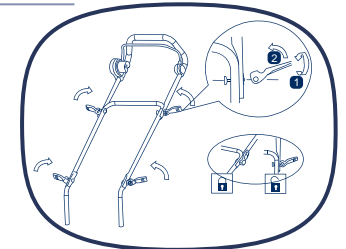

If there are any parts missing, please call the customer helpline on 01904 727505

ASSEMBLY

4 Fix the cable

- i. Ensure that the cables clips supplied are used to fix the cable to the handle.

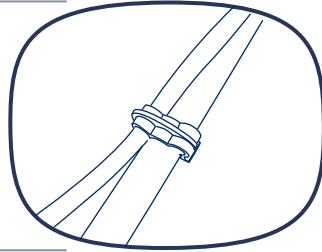

5 Assemble the grass bag

- i. Insert the grass bag handle in the upper cover of grass bag.

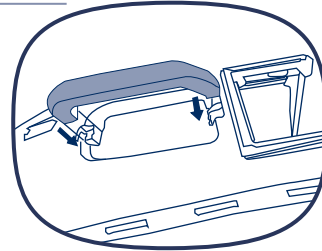

- ii. Place the metal frame inside the grass collection bag. Make sure that these clips are fully secured to the metal frame.

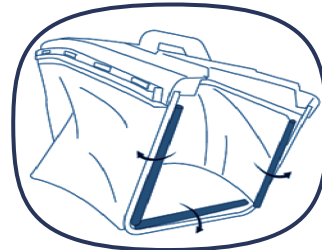

- iii. Hang the collection bag on the hook.

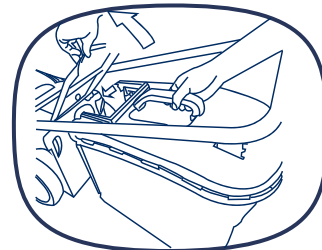

ASSEMBLY

6 Connection to the power supply

- i. Connect the extension cord to the switch box

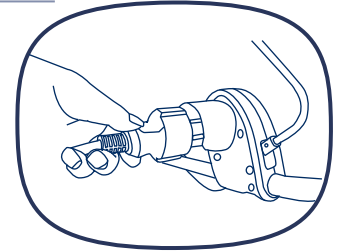

- ii. Double the extension cord, about a foot from the end. Hook the loop over the cord strain

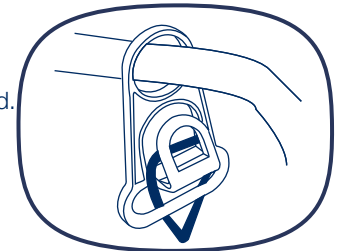

- iii. Connect the plug to the main socket

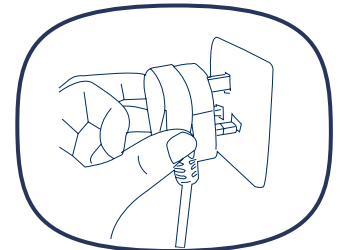

OPERATION

GENERAL OPERATION

- Check the product, its power cord and plug as well as accessories for damage before each use. Do not use the product if it is damaged or shows wear.
- Double check that accessories or cutting device are properly fixed.
- Always hold the product by its handles. Keep the handles dry to ensure safe support.
- Ensure that the air vents are always unobstructed and clear. Clean them if necessary with a soft brush. Blocked air vents may lead to overheating and damage the product.
- Switch the product off immediately if you are disturbed while working by other people entering the working area. Always let the product come to complete stop before putting it down.
- Do not overwork yourself. Take regular breaks to ensure you can concentrate on the work and have full control over the product.

NOTE: Only operate the product at reasonable hours - not early in the morning, late at night or on weekends/public holidays when people might be disturbed. Inform yourself about local restrictions.

Setting cutting height

- i. Push the adjusting lever in order to make it out of the tooth
- ii. Push the lever at the required Position (1 to 7)

NOTE: Always ensure the lever clicks back in its slot.

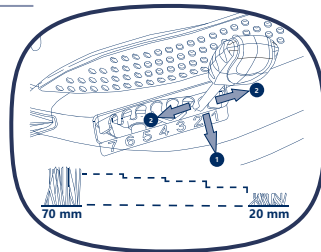

OPERATION



WARNING!

A separate extension cable is provided with your machine. If the cable is accidentally caught while mowing your lawn you only have to replace this extension cable. Please ensure you replace it with the right one. For more information visit www.spearandjackson-power.com

Connection to the power supply

- i. Connect the extension cord to the switch box and connect the plug to the main socket.

NOTE: If operating the appliance in a damp location is unavoidable, use a residual current device(RCD) protected supply. Use of an RCD reduces the risk of electric shock.

Switching on

- i. Press the button (1).
- ii. Pull the switch bar (2) towards the handle and hold in position.

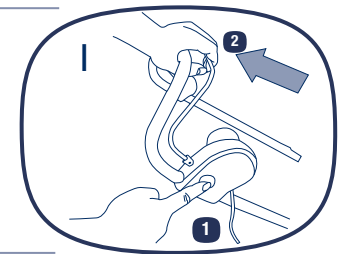

Switching off

- i. Release the switch bar.

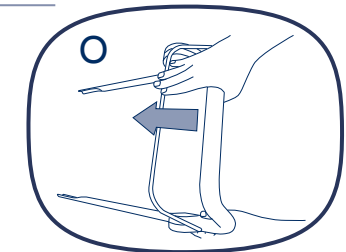

OPERATION

Mowing direction

- i. When you begin to mow please follow the arrow, so that you can avoid twist your extension cord or cut the cord.

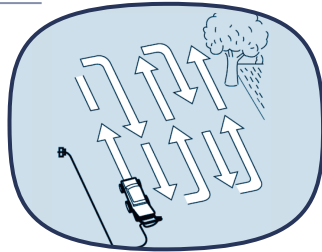

Grass bag full indicator

- i. If the collection bag is empty or it is not full with grass, the grass full indicator will open.

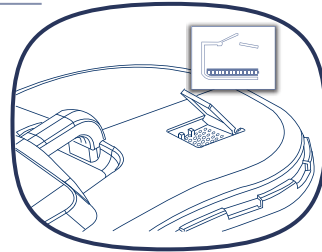

- ii. If the collection bag is full with grass the grass full indicator will close.

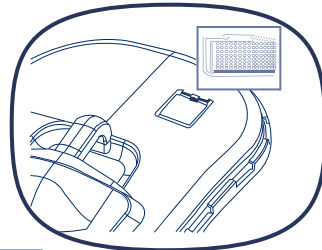

MAINTENANCE



WARNING! Always switch the product off, disconnect it from the power supply and let the product cool down before performing inspection, maintenance and cleaning work!

- i. Keep the underbody and cutting device clean and free of debris. Remove clippings from the discharge chute.
- ii. Check all nuts and bolts periodically for tightness before operation. After prolonged use, especially in sandy soil conditions, the cutting device will become worn and lose some of its original shape. The cutting efficiency will be reduced and the cutting device should be replaced.
- iii. Lubricate the cutting device after each use to prolong the life span of the cutting device and product. Apply light machine oil along the edge of the cutting device.

Replacing the cutting blade

Keep the cutting blade sharp to ensure a good cutting performance. Replace a worn or damaged cutting blade with a new one of the same type or have it sharpened by a qualified specialist.

- i. Loosen the bolt anticlockwise using a suitable wrench and remove it together with the blade.
- ii. Replace the blade with a new one of the same type.
- iii. Reattach the blade onto the spindle, pay attention to correct alignment. Tighten the bolt clockwise with 16 Nm min, 20 Nm max. to ensure safe operation of your product.

NOTE: Replace this cutting device after 50 hours mowing or 2 years whichever is sooner regardless of condition. If the cutting device is cracked or damaged, immediately replace it with a new one.

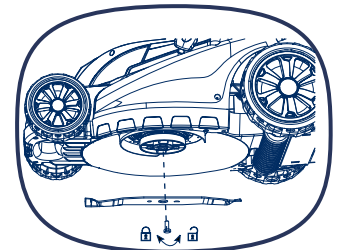

MAINTENANCE

Repair

This product does not contain any parts that can be repaired by the consumer. Contact an authorised service centre or a similarly qualified person to have it checked and repaired.

Power cord

If the power cord is damaged, it must be replaced by the manufacturer. Original spare parts can be purchased via www.spearandjackson-power.com

UK plug

If you need to replace the fitted plug, then this must be replaced using a BS1363/A Mains plug fitted with a BS1362 approved fuse of identical value to the original fuse. Proceed as follows:

IMPORTANT: The wires in the mains lead are coloured in accordance with the following code:

Blue – Neutral, Brown – Live In case the colours of the wires in the mains lead don't match the colour marking on the terminals, please proceed as follow.

Connect the blue wire to the terminal marked N (Neutral) or coloured black. The brown wire must be connected to the terminal marked L or coloured red.

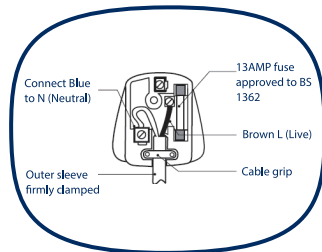

MAINTENANCE

Storage

- Switch the product off and disconnect from power supply.
- Clean the product as described above.
- To reduce storage space, the upper handle can be folded down, unscrew the wing nuts by approximately 6 revolutions.
- We recommend using the original package for storage or covering the product with a suitable cloth or enclosure to protect it against dust.

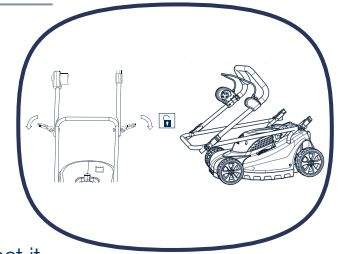

Transportation

- Switch the product off and disconnect from power supply.
- Protect the product from any heavy impact or strong vibrations which may occur during transportation in vehicles.
- Secure the product to prevent it from slipping or falling over.

Recycling and disposal

- The product comes in a package that protects it against damage during shipping. Keep the packaging until you are sure that all parts have been delivered and the product is functioning properly. Recycle the packaging afterwards.
- Old products are potentially recyclable and do not, therefore, belong in your household rubbish. You are requested to assist us and our contribution to saving resources and protecting the environment by handing in this product at an equipped collection centre (if there is one available).



TECHNICAL DATA

Model	LM1200
Input voltage rating	230-240~,50Hz
Input power	1200W
No load speed	3500 min ⁻¹
Max. cutting length	340mm
Cutting height	20-70mm, 7 adjustments
Grass catcher volume	40L
Safety class	class II
Weight	15.7kg
Protection degree	IPX4

TROUBLESHOOTING

Suspected malfunctions are often due to causes that the user can fix themselves. Therefore, check the product using this section. In most cases the problem can be solved quickly.



WARNING! Only perform the steps described within these instructions! All further inspection, maintenance and repair work must be performed by an authorised service centre or a similarly qualified specialist if you cannot solve the problem yourself!

Gloves and appropriate protective clothing must be worn when performing these instructions.

Problem	Solution
1. Motor does not run	<ul style="list-style-type: none"> · Check mains connection cable, circuit-breaker or fuse · Start on short grass or on an area which has already been mown · Clean discharge channel/housing (the mowing blade must rotate freely) · Correct the cutting height.
2. Motor power drops	<ul style="list-style-type: none"> · Correct the cutting height · Clean discharge channel/housing · Replace the mower cutter blade -see maintenance section
3. Grass catcher is not filled sufficiently	<ul style="list-style-type: none"> · Correct the cutting height · Allow the lawn to dry · Replace the mower cutter blade - see maintenance section · Clean the grille on the grass collection bag · Clean the discharge channel /housing

GUARANTEE

If your device develops a fault, please don't hesitate to contact our customer service department on 01904 727505, we can solve 80% of problems via the phone.

1. These guarantee terms cover additional guarantee rights and do not affect your statutory warranty rights. All our products are covered by a 2 year manufacturer guarantee unless this product was registered within 28 days of purchase via www.spearandjackson-power.com and therefore obtained an additional 12 month warranty.
2. Claims must be accompanied by Proof of Purchase. This must be in the form of a Sales receipt or Bank statement and must show that the product has been purchased within the guarantee period as described under point 1, from the retailer that it was originally bought from. Please keep your receipt safe or staple it to the back of this manual for future reference.
3. Our guarantee covers problems caused by material or manufacturing defects, and will result in the repair of these defects or replacement of the device with a like for like or similar article.
4. Our devices have not been designed for commercial, trade or industrial applications, any signs of use of the equipment in these application or equivalent activities, invalidates the guarantee.
5. The following are also excluded from our guarantee:
 - A. Faults due to accidents, customer misuse or unauthorized repairs
 - B. Consumable Parts such as quick release locks, extension cables, wheels, grass bags and other accessories that are compatible with the product.
 - C. Failure due to lack of routine maintenance.
 - D. Failure as a result of not using the equipment in accordance with the manual and safety instructions
 - E. The adjustment of cables, drives belts or recoil starters.

Guarantee claims should be submitted before the end of the guarantee period, see point 1, but a paid service exists for repairs commissioned after this period. The original guarantee period remains applicable to the device even if repairs are carried out or parts are replaced. In such cases, the work performed or parts fitted will not result in an extension of the guarantee period, and no new guarantee will become active for the work performed or parts fitted.

If you have any problems or questions concerning your garden power tool, please contact our after sales service at 01904 727505 or visit www.spearandjackson-power.com.

EC DECLARATION OF CONFORMITY

We

SUMEC Hardware & Tools Co., Ltd.
1XinghuoRD., Nanjing, China
And our branch office
SUMECCUK Co., Ltd.
Unit A&B Escrick Business Park
Escrick, York YO19 6 FD

Declare that the product

Electric blower vac
Factory No: SLM34KZC
Model No: LM1200
Function: Lawnmower
Serial number: LM1200-150001-150240

Complies with the following directives:

EMC Directive: 2004/108/EC
Machinery Directive: 2006/42/EC
Low Voltage Directive 2006/95/EC
Noise Directive: 2000/14/EC
RoHS Directive: 2011/65/EU
WEEE Directive 2012/19/EU

Standards conform to:

EN60335-1:2012
EN60335-2-77:2010
EN62233:2008

We additionally confirm the following in accordance with the 2000/14/EC emissions guideline:

Conformity Assessment Procedure as Per AnnexVI,
Measured sound pressure level LpA:79.8dB (A) ,k=3dB (A)
Measured sound power level LwA:92.1dB (A) ,K=2.1dB (A)
Guaranteed sound power level LwA:95dB (A)

Authorized Signatory

Date: _18-06-2015_____

Signature: 

Name: Mr. Liu Kai

General Manager

SUMEC Hardware & Tools Co., Ltd.

