



SPEAR & JACKSON

INSTRUCTION MANUAL

HIGH PRESSURE WASHER

2000W

PW2000



AFTERSALES SERVICE

01904 727505

MON-FRI 9am-5pm SAT/SUN 11am-4pm
www.spearandjackson-power.com



Important - Please read these instructions fully before operating or maintaining your pressure washer

These instructions contain important information that will help you get the best from your pressure washer, protecting your power tool investment.

THANK YOU!

Dear Customer,

Thank you for choosing a Spear and Jackson pressure washer. Spear and Jackson was founded in 1760 in the city of Sheffield, which is world famous for the production of steel, cutlery and garden and hand tools. Through continuous innovation and the use of new technologies and materials, Spear and Jackson has gained an enviable reputation as a supplier of reliable, high performance and high quality products designed to make your work in the garden as easy and enjoyable as possible.

FREE 2 YEARS GUARANTEE

We are so confident in the quality of our products we provide a free 2 year guarantee on our registered garden power tools. Simply register your product within 28 days of purchase via www.spearandjackson-power.com to extend the standard manufacturer's warranty with an additional 12 months. After registering your product, your garden power tool will be covered for parts and labour for 2 years from the date of purchase, subject to the terms of the guarantee. If you do not wish to register your product within 28 days, your product is guaranteed for 1 year after date of purchase. Therefore it's important to retain your proof of purchase.

7 DAYS A WEEK TECHNICAL SUPPORT

We want you to get the best out of your products. Our easy-to-read instruction manual guides you with best practice use and maintenance tips. You can also visit www.spearandjackson-power.com for online help, general tips and useful videos about your garden product. However if you prefer to speak to one of technicians please call **01904 727505, Mon-Fri 9am-5pm and Sat-Sun 11am-4pm**, we can solve around 80% of questions directly over the phone.

We hope you enjoy your product and looking forward to any feedback, as this allows us to develop even better products for the future.

CONTENTS

Safety Information	04
Description of symbols04
General safety05
Personal safety05
Operating safety06
Maintenance and storage safety07
Intended use07
Box Content / Parts	08
Assembly	09
Assemble gun holster and cord bracket09
Connect the hose and pressure washer09
Connect the hose and spray gun09
Fit the lance to spray gun09
Assemble inlet adapter10
Connect garden hose and inlet adapter10
Connect garden hose and water supply10
OFF position10
Connect socket10
Operation	11
Before starting11
Starting11
Stopping11
High pressure working12
Use with adjustable spray lance12
Use the turbo lance13
Use the patio cleaner13
Use the fixed brush13
Use the detergent bottle14
Maintenance	15
Overview of cleaning15
Storing, transport15
Disposal15
Technical Data	16
Troubleshooting	17
Guarantee	17

SAFETY INFORMATION

Please read these instructions fully before operating or maintaining your machine

DESCRIPTION OF SYMBOLS

The following warning symbols appear throughout this manual and indicate the appropriate safety measures you should take when operating and maintaining the pressure washer.



IMPORTANT!

Please read all of the safety and operating instructions carefully before using this tool. Please pay particular attention to all sections of this user guide that carry warning symbols and notices.



WARNING!

This is a warning symbol. This symbol is used throughout the user guide whenever there is a risk of personal injury. Ensure that these warnings are read and understood at all times.



Wear eye and ear protections.



Disconnect the mains plug immediately if the cable is damaged, has been badly twisted or is completely cut through and in the event that the device is left unattended for a short time.



WARNING!

Never direct discharge stream at persons, animals, the unit or electric components.



Appliance not suitable for connection to the portable water mains.

Water that has flown through backflow preventers is considered to be non-potable. The appliance is not intended to be connected to the potable water mains. If necessary, please use only with a water backflow preventer or, inlet hose-set approved by IEC 61770.



Double insulations, Class II appliance.



Waste Disposal and Environmental Protection!

Be environmentally friendly. Return the tool, accessories and packaging to a recycling centre when you have finished with them. Electrical machines do not belong in domestic waste. Take the equipment to a waste disposal site. The plastic and metal parts that are used can be separated out into pure grade, which allows recycling.

SAFETY INFORMATION

Please read these instructions fully before operating or maintaining your machine

GENERAL SAFETY



IMPORTANT!

- The equipment is intended for use only in premises having a service current capacity equal to or greater than 100A per phase.
- Keep this instruction manual in a safe place for future reference.
- Read the instructions carefully. Be familiar with the controls and the proper use of the equipment.
- Never allow children or people unfamiliar with these instructions to use the pressure washer. Local regulations can restrict the age of the operator.
- Never use the machine while people, especially children, or pets are nearby. Keep in mind that the operator or user is responsible for accidents or hazards occurring to other people or their property.
- This appliance is not intended for use by persons (including children) with reduced physical, sensory or mental capabilities, or lack of experience and knowledge, unless they have been given supervision or instruction concerning use of the appliance by a person responsible for their safety.
- Children should be supervised to ensure that they do not play with the appliance.

PERSONAL SAFETY



WARNING!

RISK OF FATAL INJURY!

- Use special care when cleaning tyres. Vehicle tyres/tyre valves may become

- damaged or burst when handled improperly. First signs of damage include discolorations on the tyre. Damaged vehicle tyres/tyre valves pose a life-threatening risk. Keep the jet at a distance of at least 30cm!
- Never direct the jet against yourself or others in order to clean clothes or footwear.
- The appliance is not designed for connecting to tap water. If necessary, please use only with a water backflow preventer or inlet hose-set approved by IEC 61770.
- Risk of injection or injury, do not direct discharge stream at persons.
- Do not use the appliance when there are other people around, unless they are also wearing safety equipment.
- High-pressure jets can be dangerous if misused. The jet must not be directed at persons, animals, electrical equipment or the appliance itself.
- Know how to stop the product and bleed pressure quickly, be thoroughly familiar with the controls.
- Stay alert, watch what you are doing.
- Do not operate the product when fatigued or under the influence of alcohol or drugs.
- Keep operating area clear of all persons.
- Do not overreach or stand on unstable support. Keep good footing and balance at all times.
- Always wear protective clothing and safety glasses. Loose particles and other debris may be propelled at high speed by the water jet. Wear ear protectors.
- The operator or user is responsible for accidents or damages to other people or their property.

SAFETY INFORMATION

Please read these instructions fully before operating or maintaining your machine

OPERATING SAFETY

WARNING!

- High-pressure hose fittings and couplings are important for the safety of the appliance. Use only hose fitting and couplings supplied by the manufacturer.
- Inadequate extension cables can be dangerous.
- The electrical supply connection shall be made by a qualified electrician can comply with IEC60364-1.
- The electric supply connection shall be made by a qualified electrician and comply with IEC 60364-1. It is recommended that the electric supply to this machine should include either a residual current device that will interrupt the supply if the leakage current to earth exceeds 30 mA for 30 ms or a device that will prove the earth circuit.
- Disconnect from the electrical power supply before carrying out user maintenance.
- Don't use the appliance if a supply cable or important parts of the appliance are damaged, e.g. safety devices, high-pressure hoses, trigger gun.
- If extension cable is used, the plug and socket outlet must be of a watertight construction.
- If the supply cord is damaged, it must be replaced by the manufacturer or its service agent or a similarly qualified person in order to avoid a hazard.
- Water that run through backflow preventers is considered to be non-potable.
- The PVC or polychloroprene sheathed power cord, or extension cables (H05VV-F) are

acceptable for use at temperatures at or above 0 °C.

- Always ensure that a machine which has been switched off cannot be restarted unintentionally.
- Only use hoses, fittings and couplings supplied and recommended by the manufacturer.
- Never carry the equipment by the cable or the hose. Do not carry the equipment with your finger on the On/Off switch when it is connected to the mains.
- Remove the plug from the plug socket if you are not using the equipment, when transporting it or when it is left unattended, when checking the equipment, cleaning it or removing blockages, when undertaking maintenance work or changing accessories, if the power or extension cable is damaged, after contact with foreign bodies, or in the event of abnormal vibration.
- Do not use the equipment near flammable liquids or gases. In case of non-observance, there is a risk of fire or explosion.
- Do not use the pressure washer if a supply cord, safety devices, hoses, switch or trigger gun is damaged.
- If an extension cord is used, the plug and socket must be of watertight construction. Inadequate extension cords can be dangerous.
- Ensure that the mains voltage matches the information on the label.
- Before each use check the equipment, power cable and plug for damage, to avoid an electrical shock.

SAFETY INFORMATION

Please read these instructions fully before operating or maintaining your machine

- Damaged cables, coupling and plugs or connecting leads that are not compliant with specifications are not to be used. Remove the plug from the plug socket immediately in case of damage or cutting through of the mains cable.
- Do not use the equipment when the switching action of the On/Off switch is impaired. Have damaged switches replaced at our Service Centre.
- Do not overload your equipment. Work only within the indicated range of performance. For heavy work, do not use a machine with insufficient power. Do not use your equipment for purposes other than those specified.

efficient working. Follow the maintenance directions.

- Machine may be damaged by frost. There is always residual water left inside the high-pressure washer and in the pump. Do not store the machine at temperatures below freezing point in order to avoid frost damage.

INTENDED USE

This high-pressure cleaner is designed for domestic use only:

- to clean machines, vehicles, buildings, tools, facades, terraces, garden equipment etc. using a high-pressure water jet (and detergents if required).
- to use with accessories, replacement parts and detergents approved by Spear & Jackson.

Observe the instructions provided with these detergents.

Any use of the machine that deviates from its intended use and is not included in these instructions is considered unauthorized use and relieves the manufacturer from his or her legal liability.

MAINTENANCE AND STORAGE SAFETY

WARNING!

- To ensure the appliance safety, use only original spare parts from the manufacturer or approved by the manufacturer.
- Retrofitting or making any unauthorized changes to the machine, as well as the use of unapproved parts will invalidate your warranty.
- Do not attempt to repair the equipment yourself. All work not indicated in these instructions is to be carried out only by service stations authorized by us.
- Store the equipment in a dry location and out of reach of children.
- Handle the equipment with care. Keep the equipment clean for safe and more

BOX CONTENT

PARTS

- | | |
|----------------------------|-------------------------------|
| 1 Detergent bottle x 1 | 9 Turbo lance x 1 |
| 2 High pressure washer x 1 | 10 Adjustable spray lance x 1 |
| 3 Gun holster x 1 | 11 Spray gun x 1 |
| 4 Crank x 1 | 12 Cord bracket x 1 |
| 5 High pressure hose x 1 | 13 Nozzle pin x 1 |
| 6 Patio cleaner x 1 | 14 Operating manual x 1 |
| 7 Extension lance x 1 | 15 Water inlet adapter x 1 |
| 8 Fixed brush x 1 | 16 Screws x 2 |

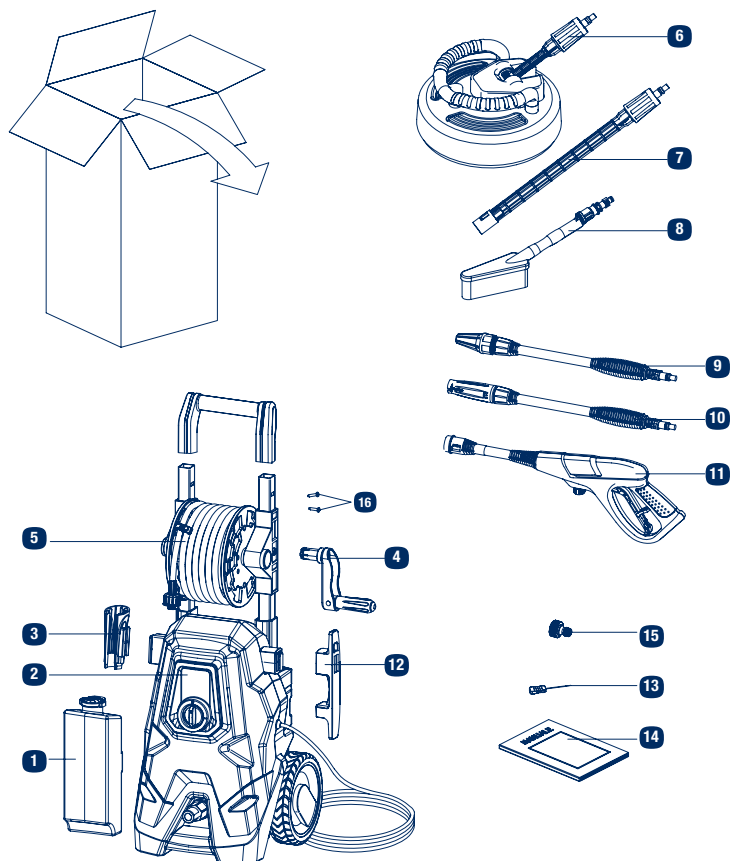

ASSEMBLY



WARNING - Pull out the power plug before carrying out any work on the equipment, and use only original parts. Before starting any cleaning task, it is important to inspect the area for objects that could create a hazard. Remove any objects from the work area that could be tripped over, such as toys or outdoor furniture. Ensure that all doors and windows are closed tightly.

- 1 Assemble Gun holster (3) and cord bracket (12).**

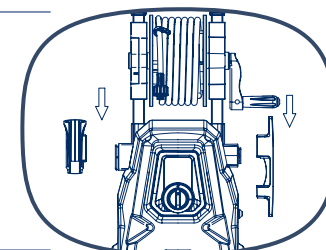

- 2 Connect the hose and spray gun.**

Screw the high pressure hose (5) firmly onto the spray gun (11).

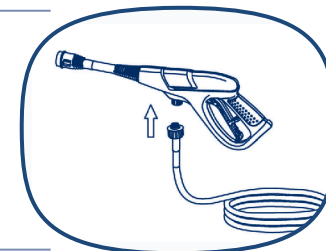

- 3 Fit the lance to spray gun.**

Insert the adjustable spray lance (10) or turbo lance (9) to spray gun (11), and twist 1/4 turn to lock in position.

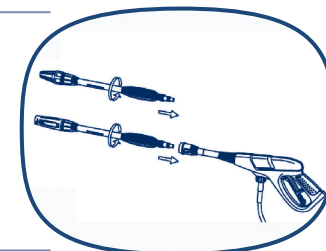

If there are any parts missing, please call the customer helpline on 01904 727505

ASSEMBLY

4 Connect garden hose and water supply.

Attach garden hose to the water supply and turn water on. Let little water run through the hose then turn it off.

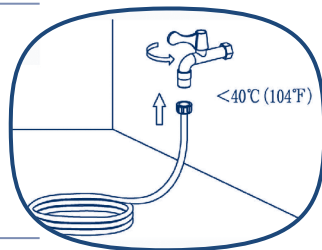

5 Assemble inlet adapter.

Attach the inlet adapter (15) to the machine's water inlet. Hand tighten only.

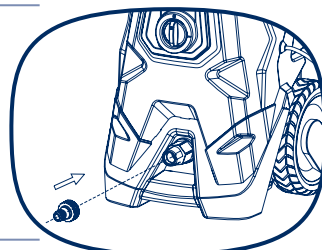

6 Connect garden hose and inlet adapter.

Attach a hose with a quick connect coupling (not included) to the high pressure washer. Turn water on.

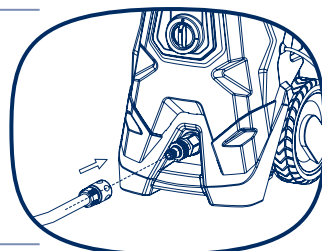

7 OFF position.

Make sure the ON/OFF switch is in the OFF position.

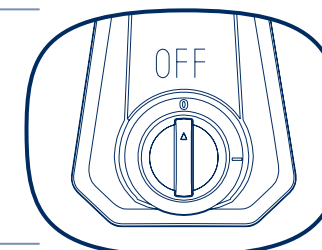

8 Connect socket.

Insert the mains plug into the socket.

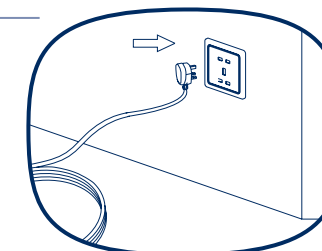

OPERATION

WARNING - Wear suitable clothing, ears and eyes protecting when working with the equipment. Ensure that the mains voltage value matches the label on the equipment.

Before starting

- Check the machine for visual defects.
- Check that all parts of the machine have been securely fitted.
- Check if the water connector and the high-pressure pipes are tight.

Starting

- Put the high pressure washer on level ground. Stand in a secure and stable position.
- Open the water inlet valve.
- Unlock the safety trigger on the spray gun, and press the trigger until there is a steady stream of water.
- To switch the machine on, set the On/Off switch to ON.

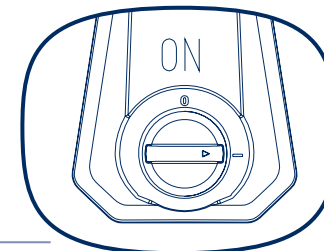
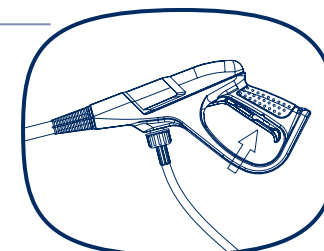

Stopping

- Release the trigger, and replace the safety lock.
- To switch the machine off, set the On/Off switch to OFF.
- Close the water inlet valve.

ATTENTION! Risk of machine damage!

Never operate the machine without the water being connected as dry running may damage the pump. Use a water filter if the inlet water is contaminated.

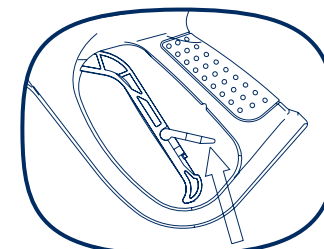

OPERATION



RISK OF FATAL INJURY!

Use special care when cleaning tyres. Vehicle tyres/ tyre valves may become damaged or burst when handled improperly. First signs of damage included discolorations on the tyre. Damaged vehicle tyres/ tyre valves pose a life-threatening risk. Keep the jet at a distance of at least 30 cm!

The high-pressure jet may be dangerous when handled improperly. The jet may not be directed towards living beings (persons, animals), live equipment or the machine itself.

High pressure working

- Switch on the high pressure washer and hold the hand-held spray gun firmly with both hands.
- Unlock the safety button and press the trigger on the handheld spray gun.
- The high-pressure pump starts running as soon as you operate the hand-held spray gun.
- The high-pressure pump stops running as soon as you release the trigger on the hand-held spray gun.

Note: Always test the surface in a small and discreet place before cleaning. Pressure washing can strip paint from surfaces and/or leave some surfaces damaged.

Use with adjustable spray lance

Ideal for lighter cleaning task like cars, bikes, patios and furniture.

The adjustable spray lance has a 180 degree rotation nozzle to adjust the width of the spray and as such the pressure on the surface.

To adjust the spray, turn the nozzle into the desired direction as shown on the nozzle.

It takes a couple of seconds for the spray to adjust to the new setting.

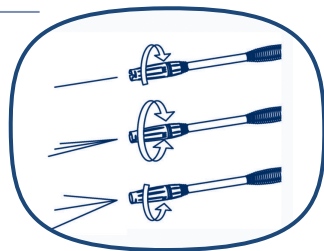

CAUTION! Jet spray adjustment is very aggressive. Do not adjust while spraying.

Switch the machine off when interrupting your work for extended periods of time.

OPERATION

Use the turbo lance

Ideal for stubborn dirt, painted wood and PVC windows, conservatories and furniture.

The turbo lance is designed to have less impact on the surface as the spray rotates around.

Note: Before you clean, always test the impact of the pressure washer on the surface on a non-prominent place.

- Stop the machine.
- Change the spray lance with turbo lance.
- Test the lance on the surface in non intrusive place.

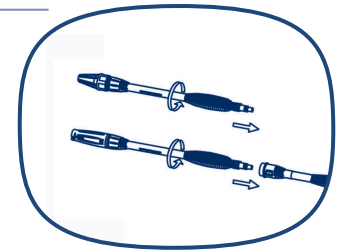

Use the patio cleaner

Ideal for cleaning areas without the splash-back of dirt like patios, fences, garage doors, gravel and pebbled pathways.

Stop the machine before changing the lance for the extension pole and patio cleaner

To clean the patio make side ways movements, instead of up and down scrubbing movements.

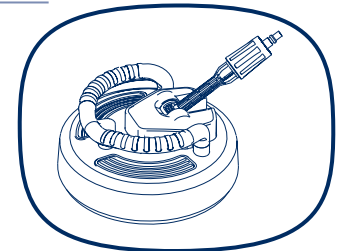

Use the fixed brush

Ideal for cleaning delicate surfaces, like vehicles and paint work, as the fixed brush is a low pressure accessory.

Stop the machine before attaching the brush to the spray gun.

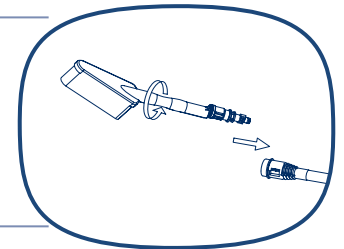

OPERATION

Use the detergent bottle

Special pressure washer detergents can be used to increase the cleaning power of the pressure washer.

Detergent can only be used with low pressure attachments like the adjustable lance in low pressure setting, the turbo lance and the fixed brush.

- i. Make sure the machine is turned off and engage the safety lock on the spray gun, before filling the detergent bottle.
- ii. Pull the lid from the bottle and fill with detergent diluted according to the fluid instructions.
- iii. Replace the lid.
- iv. Push the adjustable lance nozzle forward, configuring the machine to low pressure.

Note:

- The lance has to be set to low pressure for the machine to engage when using detergent.
- Allow detergent to remain on the surface for a short time before rinsing. Do not allow detergent to dry on surface
- Before you change the type of detergent for another job, rinse the detergent tank with clean water. Pull the trigger on the lance at low pressure for one minute until all all detergent is flushed through the system.

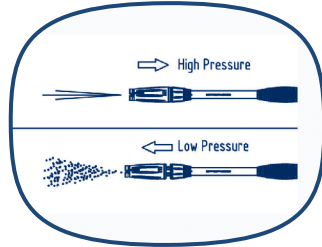
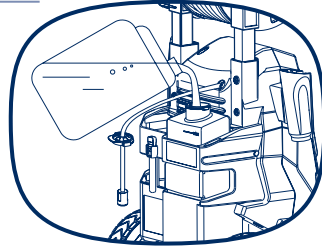

Use with waterbut or reservoir

The machine can also operate with water from sources other than a water tap, e. g. ponds and water butts. The use of an additional water filter (not supplied) is highly recommended for this kind of use.

Make sure the water source is situated no more than 1m below the level of the machine. The water inlet hose must not be too long, approx. 3 m. Fill water supply hose (not supplied) with water before connecting it to the machine. Running the machine without water (running dry) will damage it. Run machine without lance attached until there is a constant flow of water.

Turn off machine and connect lance.

Note: The internal filter of the machine is not intended for the filtration of large quantities of impurities.

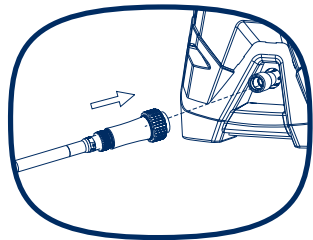

MAINTENANCE

Overview of cleaning

- After every use wipe the machine with a slightly damp cloth. Do not clean the machine using a high-pressure water jet.
- Clean the high-pressure jet nozzle.

The pressure washer is equipped with a water filter to protect the pump. If the filter is not kept clean, the water flow to the machine will be restricted and the pump may be damaged.

To clean water filter, remove inlet adapter and get the filter out.

- Rinse filter until it is free of debris and blockage.
- Replace the filter and inlet adapter.

Cleaning from lime scale

Over time water lime scale, water lime scale may build up on your lance outlet, use the nozzle cleaning pin (13) to remove this.

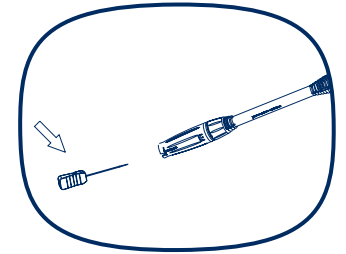
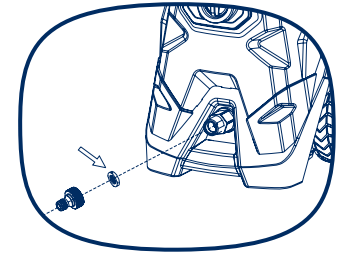

Storing

Store the machine where it is dry and well ventilated.

When placing the machine out of service for an extended period of time, remove the cleaning agent and drain all the water left in the hoses.

Transport

If shipping, use the original packaging wherever possible.

Disposal

Disposing of the machine

Machines which are labelled with the this symbol  must not be disposed of in household rubbish. You must dispose of such old electrical and electronic appliances separately.

Please check with your local authority about the possibilities for correct disposal. You will thus help to avoid that damaged materials get into the environment.

Disposing of the packaging

The packaging consists of cardboard and correspondingly marked sheets that can be recycled. Make these materials available for recycling.

TECHNICAL DATA

Model	PW2000
Input voltage rating	230 V , 50 Hz
Input power	2000W
Working pressure	11MPa
Max pressure	15MPa
Flow rate	5.5L/min.
IP number	IPX5
Safety class	class II
Inlet pressure:	0.6MPa
Supply water temperature (max.):	40°(104°F)

Part number	Accessories
01106B12	Trigger gun
01118ZF	Rotary brush
01118ZE	Fixed brush
01106B14	Spiral lance
01106BA	Vario lance
01118ZI	Patio cleaner
01118ZX	Water filter
Upgrades	(see www.spear&jackson-power.com for more information)
1106B35	90 degree nozzle
01106ZG	High performance lance
01118AR	Spray tips for metal lance

TROUBLESHOOTING

No power

- Check the plug socket, cable, line and plug, where appropriate, have it repaired via a certified electrician.
- If any of the parts are defective, such as On/Off switch / motor etc.
- Please contact after sales support at 01904 727505.

The high pressure washer operates intermittently

- Power cable is damaged.
- Internal loose electrical connection.
- On/Off switch defective
- Contact the after sales support at 01904 727505.

No or only little pressure is built up

- Check if there is any air in the system, if so, please ventilate the machine! Run the machine without the high-pressure hose connected until water starts leaking without bubbles. Re-attach the high-pressure hose.
- Check all inlet pipes leading to the pump for leaks or clogs.
- Check the setting on the hand-held spray gun.

Great pressure varieties

- Clean the high pressure jet nozzle with the nozzle pin provided (13).
- Check the water inlet pressure.

Machine is leaking

- Please contact the after sales support at 01904 727505.

GUARANTEE

If your device develops a fault, please don't hesitate to contact our customer service department on 01904 727505, we can solve 80% of questions via the phone.

1. These guarantee terms cover additional guarantee rights and do not affect your statutory warranty rights. All our products are covered by a one year manufacturer guarantee unless this product was registered within 28 days of purchase via www.spearandjackson-power.com and therefore obtained an additional 12 month warranty.
2. Claims must be accompanied by Proof of Purchase. This must be in the form of a Sales receipt or Bank statement and must show that the product has been purchased within the guarantee period as described under point 1, from the retailer that it was originally bought from. Please keep your receipt safe or staple it to the back of this manual for future reference.
3. Our guarantee covers problems caused by material or manufacturing defects, and will result in the repair of these defects or replacement of the device with a like for like or similar article.
4. Our devices have not been designed for commercial, trade or industrial applications, any signs of use of the equipment in these application or equivalent activities, invalidates the guarantee.
5. The following are also excluded from our guarantee:
 - A. Faults due to accidents, customer misuse or unauthorized repairs
 - B. Consumable Parts such as detergent bottle, patio cleaner, jet lance, fixed brush and nozzle pin, and other accessories that are compatible with the product.
 - C. Failure due to lack of routine maintenance.
 - D. Failure as a result of not using the equipment in accordance with the manual and safety instructions
 - E. The adjustment of cables, drives belts or recoil starters.

Guarantee claims should be submitted before the end of the guarantee period, see point 1, but a paid service exists for repairs commissioned after this period. The original guarantee period remains applicable to the device even if repairs are carried out or parts are replaced. In such cases, the work performed or parts fitted will not result in an extension of the guarantee period, and no new guarantee will become active for the work performed or parts fitted.

If you have any problems or questions concerning your garden power tool, please contact our after sales service at 01904 727505 or visit www.spearandjackson-power.com.

EC DECLARATION OF CONFORMITY

We

SUMEC Hardware & Tools Co., Ltd.
1XinghuoRD., Nanjing, China
And our branch office
SUMECUK Co., Ltd.
Unit A&B Escrick Business Park
Escrick, York YO 19 6FD

Declare that the product

Electric pressure washer
Model No: PW2000
Function: Clean work
Serial number: PW2000-150001-150378

Complies with the following directives:

EMC Directive: 2004/108/EC
Machinery Directive: 2006/42/EC
Low Voltage Directive 2006/95/CE
Noise Directive: 2000/14/EC
RoHS Directive: 2011/65/EU
WEEE Directive 2012/19/EU

Standards conform to:

EN 55014-1/A2:2011 EN 55014-2/A2:2008
EN 61000-3-2/A2:2009 EN 61000-3-11:2000
EN 60335-1:2012 EN 60335-2-79:2012 EN 62233:2008

We additionally confirm the following in accordance with the 2000/14/EC emissions guideline:

Conformity Assessment Procedure as Per AnnexVI,
Measured sound pressure level L_{pA} : 78.2dB (A), $k=3dB$ (A)
Measured sound power level L_{wA} : 91.6 dB (A), $K=3dB$ (A)
Guaranteed sound power level L_{wA} : 94dB (A)

Authorized Signatory

Date: 18-06-2015

Signature: 

Name: Mr. Liu Kai

General Manager

SUMEC Hardware & Tools Co., Ltd.

