

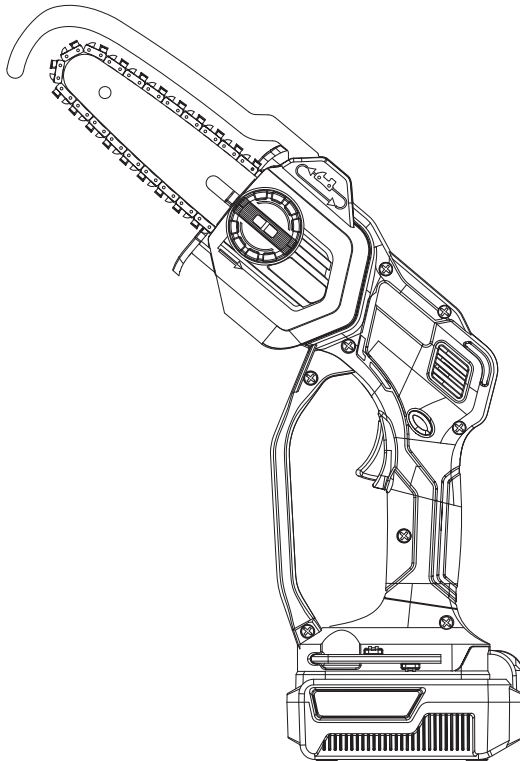

Original User's Instructions

18V Cordless Mini Pruning Chainsaw

SKU: 74317



READ BEFORE USE

PLEASE KEEP THESE INSTRUCTIONS FOR FURTHER REFERENCE

PRODUCT SUPPORT

In the unlikely event of you needing technical support, replacement part or you believe a repair is needed, please contact us in the first instance by following the steps below.



SCAN ME

STEP 1

Find your proof of purchase and scan this QR code **OR** call our helpline below

STEP 2

Get in touch with our team and receive expert technical support



STEP 3

Our team will arrange collection to repair your product under warranty **OR** an alternative resolution



STEP 4

Your product will be assessed and if required, repaired back to full working order



STEP 5

Your repaired product will be returned to you via courier within 10 days



GET IN TOUCH

 01904 947568

 support@coreservice.co.uk

We recommend you keep the original packaging, if repair is needed.

 Technical support: 9am-5pm, Mon-Fri

 Helpline: 24/7

 **HAWKSMOOR**

CONTENTS

• WHAT'S IN THE BOX -----	3
• SPECIFICATIONS -----	4
• EXPLANATIONS AND SYMBOLS, CAUTIONS AND WARNINGS -----	5
• IMPORTANT SAFETY WARNINGS -----	8
• PRODUCT DESCRIPTION AND IDENTIFICATIONS -----	22
• ASSEMBLY AND OPERATING INSTRUCTIONS -----	23
• CARE AND CLEANING -----	34
• TROUBLE SHOOTING -----	35
• DECLARATION OF CONFORMITY / PERFORMANCE -----	36
• ENVIRONMENTAL INFORMATION -----	37
• WARRANTY -----	38
• CUSTOMER SUPPORT -----	38

WHAT'S IN THE BOX

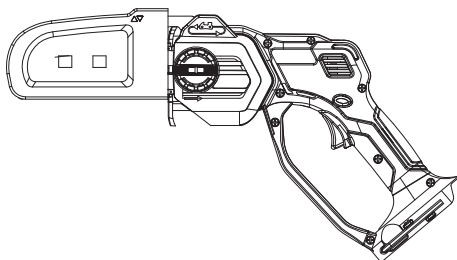

Hand-held mini pruning chainsaw

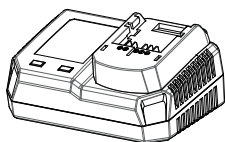

Charger



Battery



Oil bottle

Please note there is no oil supplied due to shipping restrictions, only the bottle which should be filled with chainsaw chain oil before use.

If you do not have all these items, please contact:

www.coreservice.co.uk

Hotline: +44 01904 947568

Email support@coreservice.co.uk

SPECIFICATION

Technical Data	
Model	LS C13
Mains voltage	18 V d.c.
No load chain speed	3.2 m/s
Cutting length	110 mm
Bar length	127mm
Sound pressure level: L_{pA}	67.9 dB(A), K=3
Sound power level: L_{wA}	87.9 dB(A), K=3
-Guaranteed sound power level	97dB(A)
Vibration front handle	<2.5 m/s ² ; K=1.5 m/s ²
Net weight approx.	2.7 kg
Battery pack model	B0P-SP06-18ZK
Battery capacity	4.0 Ah
Battery charging time Max	60 mins
Charger model	B0Q-SP07-2040ZZ
Battery charger input	220-240V AC, 50/60Hz 130W
Battery charger output	20V d.c. 4.5A
Protection class of battery charger	Class II

Note: The above specifications are the MAXIMUM capacities of the tool. The maximum branch diameter depends on the hardness of the wood and its branches scale. Voltage measured without workload. Initial battery voltage reaches 20 Volts. Nominal voltage is 18 Volts.

EXPLANATIONS AND SYMBOLS, CAUTIONS AND WARNINGS



Caution / Warning.



Read the instruction manual.



Wear hearing protection!
Wear eye protection!
Wear respiratory protection!



Wear protective gloves!



Wear slip-resistant, sturdy footwear!



Wear mask!



Switch the product off and disconnect it from the power supply before assembly, cleaning, adjustments, maintenance, storage and transportation.



Objects thrown by the product could hit the user or other bystanders. Always ensure that other people and pets remain at a safe distance from the product when it is in operation. In general, children must not come near the area where the product is. Minimum distance 15m.



Kickback! Tip contact may cause the guide bar to move suddenly upward and backwards what may cause serious injury to user.



Contact of the guide bar tip with any object should be avoided.



Always use the product with two hands. Do not use only one hand when operating the product.



Do not use in rain or wet conditions.



Guaranteed sound power level value



Chain oil fill



Correct direction of cutting-teeth



Caution! Risk of injury due to running blades!



Danger of falling objects.



Double insulation. Protection class II



The product complies with the applicable European Directives and an evaluation method of conformity for these Directives was done.



UK Conformity Assessed



Do not throw into water.



Do not throw to fire.



Do not subject the battery to strong sunlight over long periods of time. Do not leave on a heater (max.45°C).



Batteries contain Li-ion. Do not dispose of waste batteries in domestic waste. Contact local authority to find out how to dispose of batteries.

Li-ion



WEEE symbol. Waste electrical products should not be disposed of with household waste. Please recycle where facilities exist. Check with your Local Authority or local store for recycling advice.



The charger is for indoor use only.



Protective 3.15 A limited

IMPORTANT SAFETY WARNINGS

General Power Tool Safety Warnings



Warning: Please read the following instructions carefully, failure to do so could lead to serious personal injury. When using the electric mini pruning chainsaw, basic safety precautions, including the following, should always be followed to reduce the risk of fire, electric shock and personal injury. Read all these instructions before operating this product and save these instructions.

The term “power tool” in the warnings refers to your mains-operated (corded) power tool or battery-operated (cordless) power tool.

Become familiar with the owner’s manual before attempting to operate this machine.

- This machine is not intended for use by persons (including children) with reduced physical, sensory or mental capabilities, or lack of experience and knowledge, unless they have been given supervision or instruction concerning use of the appliance by a person responsible for their safety.
- Children should be supervised to ensure that they do not play with the appliance.
- The machine is only to be used with the power supply unit provided with the machine.

Important! Read carefully before use, keep for further reference.

Work Area Safety

- Keep work area clean and well lit. Cluttered or dark areas invite accidents.
- Do not operate power tools in explosive atmospheres, such as in the presence of flammable liquids, gases or dust. Power tools create sparks which may ignite the dust or fumes.
- Keep children and bystanders away while operating a power tool. Distractions can cause you to lose control.

Electrical Safety

- Power tool plugs must match the outlet. Never modify the plug in any way. Do not use any adapter plugs with earthed (grounded) power tools. Unmodified plugs and matching outlets will reduce risk of electric shock.
- Avoid body contact with earthed or grounded surfaces, such as pipes, radiators, ranges and refrigerators. There is an increased risk of electric shock if your body is earthed or grounded.
- Do not expose power tools to rain or wet conditions. Water entering a power tool will increase the risk of electric shock.
- Do not abuse the cord. Never use the cord for carrying, pulling or unplugging the power tool. Keep cord away from heat, oil, sharp edges or moving parts. Damaged or entangled cords increase the risk of electric shock.
- When operating a power tool outdoors, use an extension cord suitable for outdoor use. Use of a cord suitable for outdoor use reduces the risk of electric shock.
- If operating a power tool in a damp location is unavoidable, use a residual current device (RCD) protected supply. Use of an RCD reduces the risk of electric shock.

Personal Safety

- Stay alert, watch what you are doing and use common sense when operating a power tool. Do not use a power tool while you are tired or under the influence of drugs, alcohol or medication. A moment of inattention while operating power tools may result in serious personal injury.
- Use personal protective equipment. Always wear eye protection. Protective equipment such as dust mask, non-skid safety shoes, hard hat, or hearing protection used for appropriate conditions will reduce personal injuries.
- Prevent unintentional starting. Ensure the switch is in the off-position before connecting to power source and/or battery pack, picking up or carrying the tool. Carrying power tools with your finger on the switch or energizing power tools that have the switch on invites accidents.
- Remove any adjusting key or wrench before turning the power tool on. A wrench or a key left attached to a rotating part of the power tool may result in personal injury.
- Do not overreach. Keep proper footing and balance at all times. This enables better control of the power tool in unexpected situations.
- Dress properly. Do not wear loose clothing or jewelry. Keep your hair and clothing away from moving parts. Loose clothes, jewelry or long hair can be caught in moving parts.
- If devices are provided for the connection of dust extraction and collection facilities, ensure these are connected and properly used. Use of dust collection can reduce dust-related hazards.
- Do not let familiarity gained from frequent use of tools allow you to become complacent and ignore tool safety principles. A careless action can cause severe injury within a fraction of a second.

Power Tool Use and Care

- Do not force the power tool. Use the correct power tool for your application. The correct power tool will do the job better and safer at the rate for which it was designed.
- Do not use the power tool if the switch does not turn it on and off. Any power tool that cannot be controlled with the switch is dangerous and must be repaired.
- Disconnect the plug from the power source and/or remove the battery pack, if detachable, from the power tool before making any adjustments, changing accessories, or storing power tools. Such preventive safety measures reduce the risk of starting the power tool accidentally.
- Store idle power tools out of the reach of children and do not allow persons unfamiliar with the power tool or these instructions to operate the power tool. Power tools are dangerous in the hands of untrained users.
- Maintain power tools and accessories. Check for misalignment or binding of moving parts, breakage of parts and any other condition that may affect the power tool's operation. If damaged, have the power tool repaired before use. Many accidents are caused by poorly maintained power tools.
- Keep cutting tools sharp and clean. Properly maintained cutting tools with sharp cutting edges are less likely to bind and are easier to control.
- Use the power tool, accessories and tool bits etc. in accordance with these instructions, taking into account the working conditions and the work to be performed. Use of the power tool for operations different from those intended could result in a hazardous situation.
- Keep handles and grasping surfaces dry, clean and free from oil and grease. Slippery handles and grasping surfaces do not allow for safe handling and control of the tool in unexpected situations.

Service

- Have your power tool serviced by a qualified repair person using only identical replacement parts. This will ensure that the safety of the power tool is maintained.

Product Safety Warnings

Mini Pruning Chainsaw Safety Warnings:

- Use the tool only with specifically designated battery packs. Use of any other battery packs will increase the risk of injury and fire.
- Only operate the product in daylight or in good artificial light.
- Interrupt your work when you feel tired or exhausted. Make regular breaks to regenerate. A moment of inattention while operating the product may result in serious personal injury.
- Do not expose tool and charger to rain or wet conditions. If a tool or charger is exposed to moisture it will increase the risk of electric shock, battery damage, fire or explosion.
- Keep all parts of the body away from the saw chain when the chain saw is operating. Before you start the chain saw, make sure the saw chain is not contacting anything. A moment of inattention while operating chain saws may cause entanglement of your clothing or body with the saw chain.
- Keep all parts of the body away from the saw chain. Do not remove cut material or hold material to be cut when saw chain is moving. Make sure the switch is off when clearing jammed material. A moment of inattention while operating the product may result in serious personal injury.
- Always hold the product with both hands on the handle and soft grip. Holding the product with only one hand or on parts not intended for that increases the risk of personal injury and should never be done.

- Hold the power tool by insulated gripping surfaces only, because the saw chain may contact hidden wiring. Saw chains contacting a “live” wire may make exposed metal parts of the power tool “live” and could give the operator an electric shock.
- Keep cable away from cutting area. During operation the cable may be hidden in shrubs and can be accidentally cut by the saw chain.
- Wear safety glasses protection. Further protective equipment for hearing, head, hands, legs and feet is recommended. Adequate protective clothing will reduce personal injury by flying debris or accidental contact with the saw chain.
- Do not operate a chain saw in a tree, on a ladder, from a rooftop, or any unstable support. Operation of a chain saw in this manner could result in serious personal injury.
- Always keep proper footing and operate the chain saw only when standing on fixed, secure and level surface. Slippery or unstable surfaces may cause a loss of balance or control of the chain saw.
- When cutting a limb that is under tension, be alert for spring-back. When the tension in the wood fibers is released, the spring-loaded limb may strike the operator and/or throw the chain saw out of control.
- Use extreme caution when cutting brush and saplings. The slender material may catch the saw chain and be whipped toward you or pull you off balance.
- Carry the product by the soft grip with the product switched off and away from your body. When transporting or storing the product always fit the guide bar cover. Proper handling of the product will reduce the likelihood of accidental contact with the moving saw chain.
- Follow instructions for lubricating, chain tensioning and changing the bar and chain. Improperly tensioned or lubricated chain may either break or increase the chance for kickback.

- Keep handles dry, clean, and free from oil and grease. Greasy, oily handles are slippery causing loss of control.
- Use the harness provided.
- Cut wood only. Do not use chain saw for purposes not intended. For example: do not use chain saw for cutting metal, plastic, masonry or non-wood building materials. Use of the chain saw for operations different than intended could result in a hazardous situation.
- Pay attention to national and local regulations. National and local regulations may restrict the use of this product.
- Do not attempt to fell a tree until you have an understanding of the risks and how to avoid them. Serious injury could occur to the operator or bystanders while felling a tree.
- Only use replacement guide bars and saw chains specified by the manufacturer or equivalent replacements. Using non-approved cutting attachments can result in personal injuries and damage to property.
- Before using the product and after any impact or dropping, check for signs of wear or damage and repair as necessary.
- Never remove or modify any guard or safety component. Ensure that guards and other safety components necessary for machine operation are in position, in good working condition and properly maintained to avoid injuries.
- Follow all instructions when clearing jammed material, storing or servicing the chain saw. Make sure the switch is off and the battery pack is removed. Unexpected actuation of the chain saw while clearing jammed material or servicing may result in serious personal injury.
- Recommendation that training of all operation is necessary for first-time and inexperienced operator.
- Recommendation to have sharpening and maintenance of the saw chain performed by authorised service centres.

Causes and Operator Prevention of Kickback:

Kickback may occur when the nose or tip of the guide bar touches an object, or when the wood closes in and pinches the saw chain in the cut.

Tip contact in some cases may cause a sudden reverse reaction, kicking the guide bar up and back towards the operator.

Pinching the saw chain along the top of the guide bar may push the guide bar rapidly back towards the operator.

Either of these reactions may cause you to lose control of the saw which could result in serious personal injury. Do not rely exclusively upon the safety devices built into your saw. As a chain saw user, you should take several steps to keep your cutting jobs free from accident or injury.

Kickback is the result of tool misuse and/or incorrect operating procedures or conditions and can be avoided by taking proper precautions as given below:

- Maintain a firm grip, with thumbs and fingers encircling the chain saw handles, with both hands on the saw and position your body and arm to allow you to resist kickback forces. Kickback forces can be controlled by the operator, if proper precautions are taken. Do not let go of the chain saw.
- Do not overreach and do not cut above shoulder height. This helps prevent unintended tip contact and enables better control of the chain saw in unexpected situations.
- Only use replacement bars and chains specified by the manufacturer. Incorrect replacement guide bars and saw chains may cause chain breakage and/or kickback.
- Follow the manufacturer's sharpening and maintenance instructions for the saw chain. Decreasing the depth gauge height can lead to increased kickback.

Vibration and Noise Reduction

To reduce the impact of noise and vibration emission, limit the time of operation, use low-vibration and low- noise operating modes as well as wear personal protective equipment.

Take the following points into account to minimize the vibration and noise exposure risks:

1. Only use the product as intended by its design and these instructions.
2. Ensure that the product is in good condition and well maintained.
3. Use correct application tools for the product and ensure they in good condition.
4. Keep tight grip on the handles/grip surface.
5. Maintain this product in accordance with these instructions and keep it well lubricated (where appropriate).
6. Plan your work schedule to spread any high vibration tool use across a longer period of time.

The European Physical Agents (Vibration) Directive has been brought in to help reduce hand arm vibration syndrome injuries to users of product's with vibration emission. The directive requires manufacturers and suppliers to provide indicative vibration test results to enable users to make informed decisions as to the period of time a product can be used safely on a daily basis and the choice of tool. Further advice can be found at www.hse.gov.uk

Emergency

Familiarise yourself with the use of this product by means of this instruction manual. Memorise the safety directions and follow them to the letter. This will help to prevent risks and hazards.

1. Always be alert when using this product, so that you can recognise and handle risks early. Fast intervention can prevent serious injury and damage to property.
2. Switch off and disconnect from the power supply if there are malfunctions. Have the product checked by a qualified professional and repaired, if necessary, before you operate it again.



WARNING! This product produces an electromagnetic field during operation! This field may under some circumstances interfere with active or passive medical implants! To reduce the risk of serious or fatal injury, we recommend persons with medical implants to consult their doctor and the medical implant manufacturer before operating this product!

Residual Risks:

Even with the intended use of the appliance there is always a residual risk, which can not be prevented. According to the type and construction of the appliance the following potential hazards might apply:

- Contact with exposed saw teeth of the saw chain (cutting hazards)
- Access to the rotating saw chain (cutting hazards)
- Unforeseen, abrupt movement of the guide bar (cutting hazards)
- Flung out of parts from the saw chain (Cutting / injection hazards)

- Flung out of parts of the work piece
- Skin contact with the oil
- Loss of hearing, if no required ear protection used during work

Safety Warning For Battery Pack

- Fully charge battery pack before the first use.
- Recharge battery pack when the power output starts to slow. **Do not continue to use product when battery capacity level is low.**
- To prevent serious damage to the battery pack, charge in temperatures above 5°C or below 45°C. Longest life and best performance can be achieved when battery is charged at room temperature (20 °C ± 5 °C).
- If the battery temperature is hot after use, it must be allowed to cool before putting it into the charging station.
- If the battery pack becomes too hot during charging, disconnect and switch off immediately. Contact the service centre directly.
- **Do not dismantle, open or shred cells or battery pack.**
- **Do not short-circuit a battery pack.** Do not store battery packs haphazardly in a box or drawer where they may short-circuit each other or be short-circuited by conductive materials. **When battery pack is not in use, keep it away from other metal objects, like paper clips, coins, keys, nails, screws or other small metal objects, that can make a connection from one terminal to another. Shorting the battery terminals together may cause burns or a fire.**
- Do not carry individual battery packs in your pockets or bag as they could short-circuit against other metal items.
- Do not expose battery pack to heat or fire. Avoid use or storage in direct sunlight for extended periods of time.
- Do not subject battery pack to mechanical shock.

- In the event of battery leaking, do not allow the liquid to come into contact with the skin or eyes. If contact has been made, wash the affected area with copious amounts of water and seek medical advice.
- Should a Li-ion battery catch fire, ensure to use the correct fire extinguisher to combat the fire. Do not throw or spray water on a burning Li-ion battery.
- Keep battery pack clean and dry. Wipe the battery pack terminals with a clean dry cloth if they become dirty.
- Battery pack needs to be charged before use. Always refer to this instruction and use the correct charging procedure.
- Do not maintain battery pack on charge when not in use.
- After extended periods of storage, it may be necessary to charge and discharge the battery pack several times to obtain maximum performance.
- Battery pack gives its best performance when it is operated at normal room temperature ($20\text{ }^{\circ}\text{C} \pm 5\text{ }^{\circ}\text{C}$).
- When disposing of battery packs, keep battery packs of different electrochemical systems separate from each other.
- Recharge only with the charger specified by manufacturer. Do not use any charger other than that specifically provided for use with the equipment. A charger that is suitable for one type of battery pack may create a risk of fire when used with another battery pack.
- Do not use any battery pack which is not designed for use with the equipment.
- Keep battery pack out of the reach of children.
- Retain the original product literature for future reference.
- Remove the battery from the equipment when not in use.
- Dispose of properly.

- Do not mix cells of different manufacture, capacity, size or type within a device.
- Do not remove battery pack from its original packaging until required for use.

Safety Warning For Battery Charger

- Charge only battery pack of the same model provided by manufacturer and of models recommended by manufacturer.
- Do not use the original charger on other Li-ion batteries or on any other type of battery as this can increase the risk of fire or explosion.
- Check the battery charger, cable and plug before each use. Do not use the battery charger if damaged. Do not open the battery charger yourself, charger must be repaired by qualified personnel using original spare parts.
- The charger is designed to use a standard household 220-240 V~ 50Hz power source, ensure that the plug matches the outlet.
- Never modify the plug in any way, this will reduce the risk of electric shock.
- Do not abuse the cord of charger. Never use the cord for carrying, pulling or unplugging the charger. Keep cord away from heat, oil, sharp edges or moving parts. Damaged or entangled cords increase the risk of electric shock.
- Make sure the charger cord is situated so that it will not be stepped on, tripped over or get damaged.
- If the supply cord is damaged, it must be replaced by the manufacturer, its service agent or similarly qualified persons in order to avoid a hazard.
- Keep the battery charger clean. Contamination can increase the risk of electric shock.

- Protect the battery charger from rain and moisture. If water accesses the battery charger there is an increased risk of electric shock.
- Battery will heat up whilst charging. When charging batteries, ensure that the battery charger is in a well-ventilated area and to reduce the risk of fire, do not operate battery charger on or close to inflammable materials such as paper or textiles.
- Do not overcharge any batteries. Ensure that batteries and chargers are not left unsupervised during charging.
- The temperature range over which the battery pack can be charged is typically between 5°C-45°C. Attempts to charge out with the prescribed temperature range may automatically be blocked by the protection circuitry of the battery pack. Longest life and best performance can be obtained if the battery pack is charged at room temperature.
- Disconnect charger from the power supply when not in use. This will reduce the risk of electric shock or damage to the charger.
- This charger can be used by children aged from 8 years and above and persons with reduced physical, sensory or mental capabilities or lack of experience and knowledge if they have been given supervision or instruction concerning use of the appliance in a safe way and understand the hazards involved.
- Children shall not play with the appliance. Cleaning and user maintenance shall not be made by children without supervision.

PRODUCT DESCRIPTION AND IDENTIFICATIONS

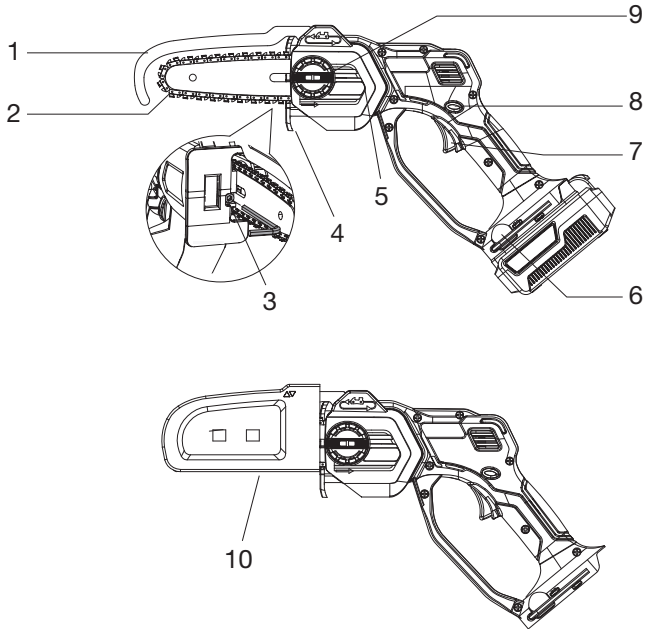

1. Chain guard
2. Bar & Chain
3. Chain tensioning hex screw
4. Base plate
5. Sprocket cover
6. Hex key
7. Trigger switch
8. Lock off switch
9. Knob screw
10. Bar & chain cover sheath

Not all the accessories illustrated or described are included in standard delivery.

ASSEMBLY AND OPERATING INSTRUCTIONS



NOTE: To reduce the risk of injury, user must read instruction manual.

Intended Use

The mini pruning chainsaw is intended for removing branches from trees. It is not suitable for extensive sawing work and felling trees or for the sawing of materials other than wood. Please observe that our machine was not designed for use in commercial, technical or industrial applications.

We assume no liability if the machine is used in commercial, technical or industrial applications or for equivalent activities.



WARNING: Before assembly and adjusting to the mini pruning chainsaw, ensure the mini pruning chainsaw is turned off and the battery pack is removed.

Remove the chain cover sheath (10)

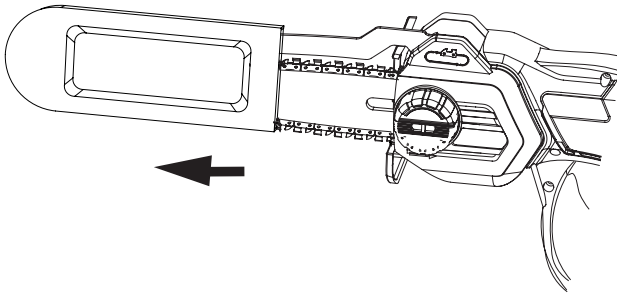

BEFORE OPERATION



WARNING: The charger and battery pack are specially designed to work together so do not attempt to use any other devices. Never insert or allow metallic objects into your charger or battery pack connections otherwise an electrical failure and hazard will occur.

NOTE: The battery pack comes partly charged. Charge the battery pack prior to first use, ideally at least 60 minutes.

- Always pull the plug of the charger from the mains before removing or connecting the battery pack to the charger.
- Never charge the battery pack when the ambient temperature is below 5°C or above 45°C.
- Never recharge a battery pack again immediately after rapid charging. This could overcharge the battery pack, thus reducing the lifespan of the battery pack and charger.
- Rest the charger for at least 15 minutes between continuously charging sessions.

Checking battery capacity

Press the battery capacity level button to check the charging level of the battery pack. The status/remaining capacity will be shown on the battery charging level indication light.

3 Green LED on	Battery pack fully charged
2 Green LED on	Battery pack 65% charged
1 Green LED on	Battery pack 35% charged
No LED lit	Battery is dead and needs to be charged

Charge the battery pack before operating when it is at medium or low battery charging level.

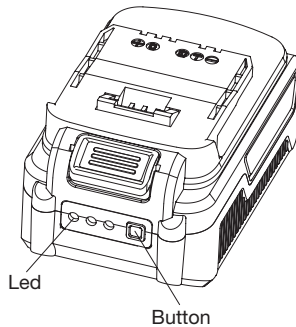

Charging procedure

- 1) Slide the battery pack into the charger base to make connections.
- 2) Connect the battery charger to the power supply. The indicator light will be red to show that the charging has started.
- 3) When charging is completed, the light will turn to green. The pack is now fully charged, unplug the charger and remove the battery pack.

Charging light indicator

Red LED on; Green LED off	Charger ready
Red LED on; Green LED flashes	Battery pack charging
Red LED off; Green LED on	Battery pack fully charged
Red LED flashes; Green LED off	Battery pack too cold or hot
Red LED flashes faster; Green LED off	Battery pack defected

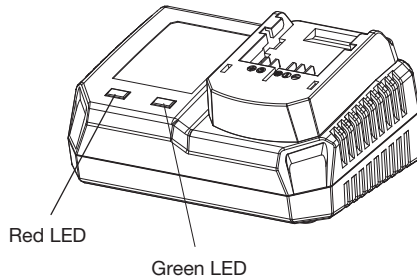

WARNING: When battery pack runs out after continuous use or exposure to direct sunlight or heat, allow time for the pack to cool down before re-charging to achieve the full capacity.

To obtain the best life from the battery

1. Never allow the battery to completely discharge before recharging. The battery pack should be placed on the charger whenever the battery pack is noticeably running down or the tool no longer performs a task it previously performed.
2. Avoid conducting short charges. Make sure that the battery is fully charged each time by allowing the charger to complete its full charging cycle.
3. Avoid allowing loose items like screws or nails etc. to be stored with battery packs as these or similar items can short battery packs and cause a fire or explosion
4. Always unplug the charger when not in use and store in a dry and secure place.
5. Avoid charging or storing your battery in temperatures below 5°C and above 45°C.
6. After use, allow the battery pack to cool down for approximately 30 minutes before attempting to recharge.

To insert the battery pack

1. Align the groove on the battery pack with the corresponding ribs on the mini pruning chainsaw.
2. Insert the battery pack until it locks into place with a click.

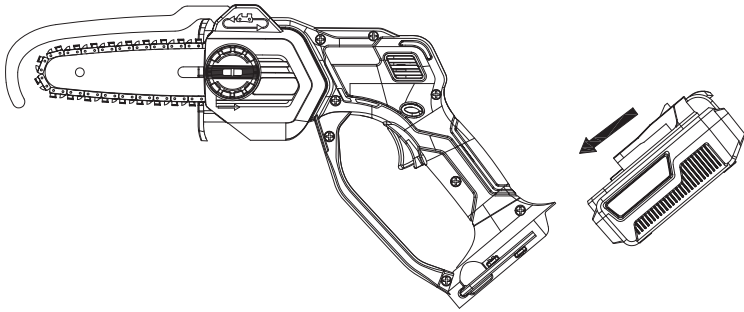

To remove the battery pack from the tool

1. Press the battery pack release button.
2. Remove the battery pack by sliding away from the tool.

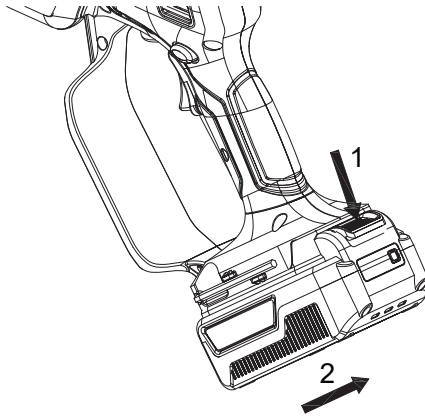

Check before starting!

DANGER! Risk of injury! The device must only be put into operation if no faults are found. If any part of the device is defective, it must be replaced before the next use.

Check the safety equipment and the safe condition of the device.

- Check all parts to make sure they fit tightly.
- Check whether there are visible defects: broken parts, cracks, etc. If you do see any damage or missing parts, please ensure the product is complete before use. For support see page 2 or 40.

Switching ON and OFF

NOTE: Lubricate the chainsaw before turning the machine on. The use of the hand held mini pruning chainsaw without lubricating the chain with chain oil will damage the saw chain and the guide bar.

For saw chain lubricating, refer to section "**Lubricate the saw chain**" on page 33.

1. Hold the hand held mini pruning chainsaw firmly and securely by the handgrip. To switch on the machine, first press the lock-off switch (8) and then press the trigger switch (7).
2. To switch off the saw, release the trigger switch (7).

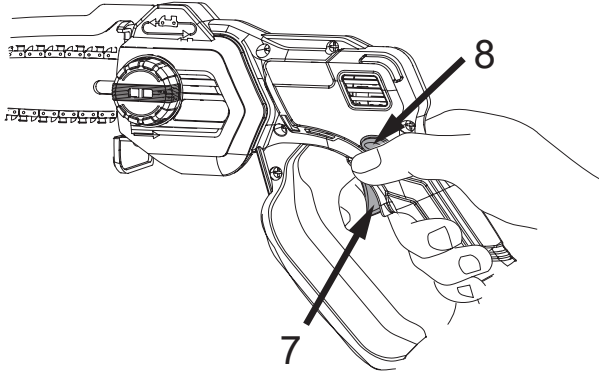

Break-in time for new saw chains

1. Remove the battery, lubricate the chain and adjust the tension of the chain. For chain tensioning operation, refer to section "**Re-mounting the saw chain**" or "**Adjust saw chain tensioning**" on page 29 and 33.
 2. Put the battery pack to the machine and switch the machine on. Allow to run idly for approximately 5 minutes.
 3. Remove the battery and check the chain tension. If necessary, retighten the chain.
 4. Once the chain is broken in and set at the correct tension, make light cuts for approximately 30 minutes, ensuring the chain is sufficiently lubricated. After 30 minutes the saw can be used for heavier pruning.
- Use only sharp saw chains. Blunt saw chains can jam more easily. Check the chain tensioning more frequently when working with new saw chains, as the new chain expands more at the beginning stage of use.
 - The service life of a saw chain depends on sufficient lubrication and the correct tensioning.
 - During operation, the chain heats up and re-tensioning may be necessary. When storing the mini chainsaw, you should always slacken the chain after use.
 - Do not re-tension a chain that has become too hot as it may become too tight on the bar. Always allow the chain to cool in this instance.
 - The tension of the saw chain is important for your safety and the function of the machine. A correctly tensioned saw chain increases the service life of the machine.

- Check the chain tension before each use.
- The saw chain is correctly tensioned if it can be pulled around the guide bar groove by hand (wear protective gloves) without sagging.
- With new saw chains, you must readjust the chain tension after a short period of operation.

Work instructions

- Hands or any part of body should never reach over the safety bar or under the base plate. There is a risk of injury.
- Do not turn on the machine if the saw chain is in contact with the workpiece or in the workpiece. It may kickback. This can lead to serious injuries.
- Clamp loose workpiece before cutting when using the hand-held mini pruning saw detached from the telescopic pole. Remove foreign objects such as nails, screws, etc.
- When cutting a branch that is under tension be alert for spring back. When the tension in the wood fibres is released, the spring-loaded limb may strike the operator and/or throw the machine out of control.
- Use extreme caution when cutting brush and saplings. The slender material may catch the saw chain and be whipped toward you or pull you off balance.
- When the saw chain is running. First place the base plate on the surface of the workpiece and let the saw cut on its own. Apply only light pressure to the saw. The chain speed should not be much slower.

Re-mounting the saw chain

Risk of injury! Always wear gloves when handling the saw chain.

1. Unscrew the know screw(9) counter-clockwise in order to remove the sprocket cover(5).

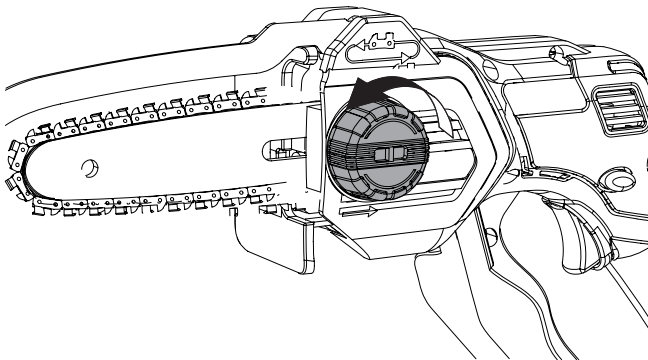

2. Hold the guide bar still and slide and wrap the chain in the groove around the guide bar. Ensure the chain tooth is in the correct running direction by comparing it to the chain icon on the guide bar and the machine.

Hold the guide bar still and fit the chain onto the drive sprocket. While lining up the slot in the middle of the guide bar with the position bolt on the machine. Align the tensioning hole on the guide bar to the chain tensioning bolt on the machine.

Make sure the cutting teeth direction of the chain match the saw chain tooth icon shown on the machine.

Assure all parts are seated properly. Make sure the drive links are fully seated in the drive sprocket, avoiding a kink.

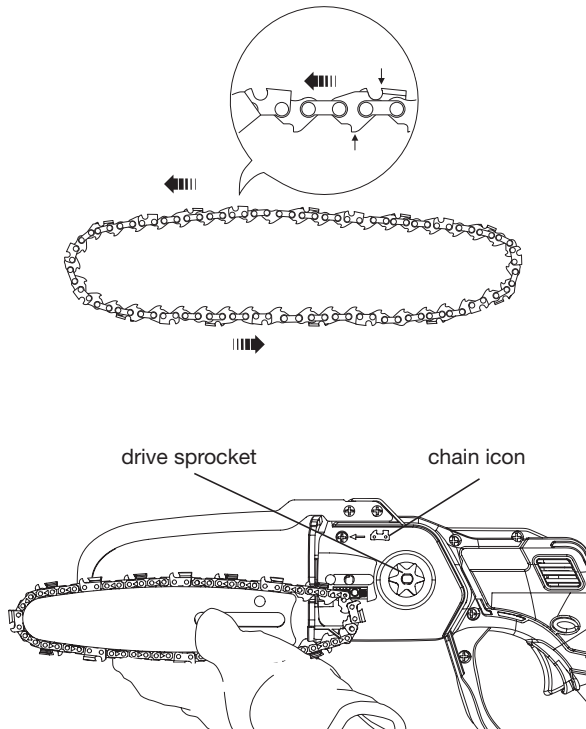

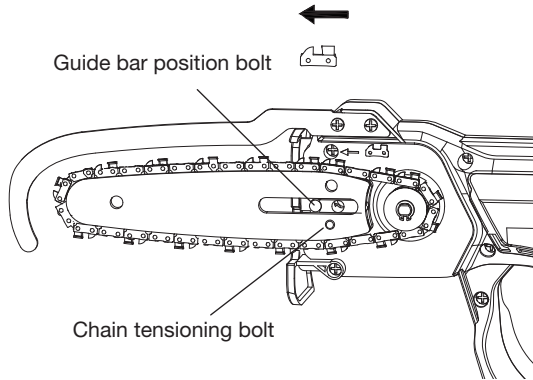

3. Replace the sprocket cover(5) onto the machine and insert the knob screw(9) into the middle hole of the sprocket cover(5). Turn the knob screw(9) clockwise to securely tighten the sprocket cover(5).

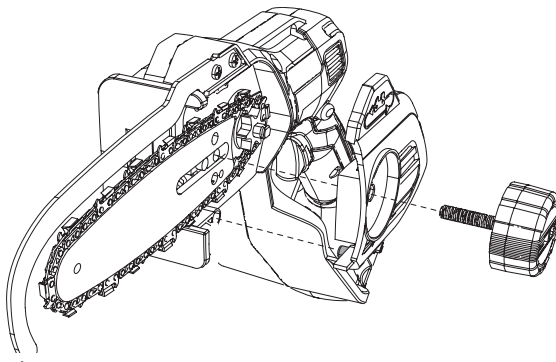

4. Use the hex key(6) attached on the chainsaw to adjust the chain tension by the chain tensioning hex screw(3)z showed in the figure below.

The tension is correct when the chain snaps back after being pulled 2 mm away from the guide bar with light force from the index finger and thumb as shown in Figure below. There should be no “sag” between the guide bar and the chain on the underside. Rotate the chain tensioning knob screw clockwise until the chain tension is correct as instructed above.

Do not over-tension the chain as this will lead to excessive wear and will reduce the life of the bar and chain.

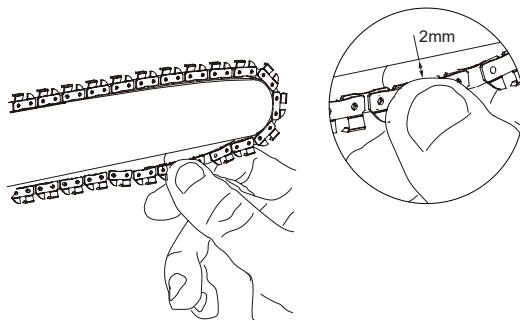
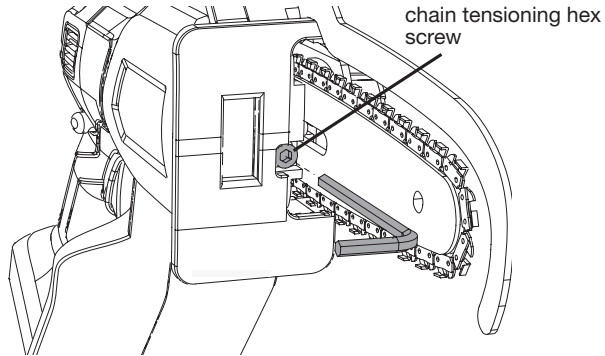

Lubricate the saw chain

Use a high quality bar and chain oil for proper chain and bar lubrication. As a temporary substitute, a non-detergent SAE30 weight motor oil can be used. The use of a vegetable based bar and chain oil is recommended when pruning trees. Mineral oil is not recommended because it may harm trees. Never use waste oil or very thick oil. These may damage your chainsaw.

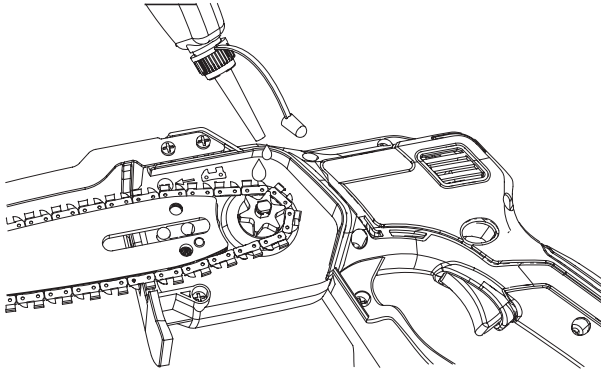

Adjust saw chain tensioning



CAUTION: Do not tighten the saw chain too much. Excessively high tension of saw chain may cause breakage of saw chain, wear of the guide bar and breakage of the sprocket.



CAUTION: A chain which is too loose can jump off the guide bar.

The saw chain may become loose after use. From time to time check the saw chain tension before use.

1. Remove the battery.
2. Loosen the locking wheel a bit to loosen the sprocket cover lightly.
3. Adjust the chain tension. Turn the chain chain tensioning hex screw clockwise to tighten, turn it counter- clockwise to loosen. The tension is correct when the chain snaps back after being pulled 2 mm away from the guide bar with light force from the index finger and thumb. There should be no "sag" between the guide bar and the chain on the underside.
4. Tighten the locking wheel to secure the sprocket cover.

Kick-back

- The shape of the riving knife largely eliminates the risk of kick-back.
- The saw is optimally protected against kick-back by the riving knife with tip protection. Never remove the riving knife. There is a risk of injury!

Sharpen the saw chain

- The saw teeth must be sharpened if the sawdust becomes powdery, if additional force is required for the incision, if a straight incision is no longer possible or if the vibrations increase.
- Blunt saw chains should be re-sharpened.
- To sharpen the chain use a chain sharpener. Make sure you sharpen the chain at a 30° angle.
- Or have the chain re-sharpened professionally (advised).
- Replace the saw chain if there is considerable damage that cannot be repaired by filing. See page 2 and 40 for product support and spare parts.

Cleaning the guide bar

- Thoroughly clean the notch of the guide bar.
- Replace the guide bar if the guide groove is damaged or worn and the saw chain has too much lateral space.

Do not use water or spray water to clean wood cutting residue or dust on the mini pruning chainsaw. Use a brush or air gun to clean the machine.

- Tighten all accessible screws, if necessary.

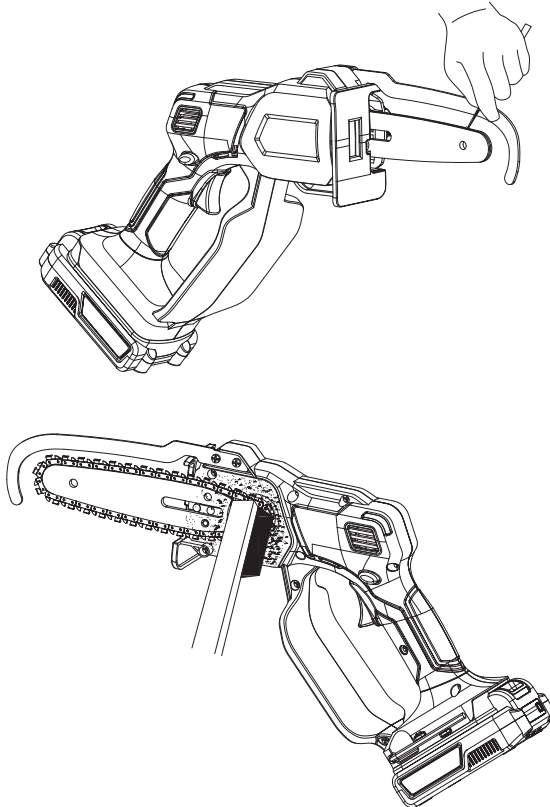

CARE AND CLEANING



WARNING! To avoid serious injuries, always switch off and remove the battery before cleaning or maintenance. Wear protective gloves and goggles when cleaning the mini pruning chainsaw.



WARNING! Have repairs and maintenance work that are not described in these instructions carried out by our service centre. Use only original parts.

Cleaning

- The device must neither be sprayed with water nor placed in water. There is a risk of electric shock.
- Keep the ventilation slots, motor housing and handles of the device clean. Use a soft cloth or brush to do this. Do not use cleaning agents or solvents. This could cause irreparable damage to the device.
- Keep the ventilation slots free of dust and debris to prevent the cordless mini pruning chainsaw from overheating.
- Clean the blower regularly with a soft cloth, preferably every time you use it. If the dust or wood residue doesn't come out, remove the dust or wood residue by blowing them out with compressed air.

Maintenance and storage

- Keep all nuts, bolts and screws tight to be sure the mini pruning chainsaw is in safe working condition.
- Regularly lubricate all moving parts.
- There are no parts that can be repaired by the user inside the saw. If the parts are worn or damaged, replace them with parts provided by Toolstation or qualified service centre.
- Store the machine in a dry place out of the reach of children. Remove the battery before storage of the machine.
- If a Li-ion battery has been stored over a longer period, the charge level must be regularly checked. Store the battery for long periods around 50-60% charge for best battery health.
- When you stop the chainsaw for inspection, servicing, storage, or changing accessory, switch off the chainsaw and make sure that all moving parts come to a complete stop, and remove the battery pack. Cool down the chainsaw before making any work on the chainsaw. Maintain the machine with care and keep it clean.
- Always cool down the machine before storing.
- Remove the battery pack before transport. Always carry the saw using the handle during transport. Secure the saw against slipping and tilting during transport. Protect the saw against damage and intense vibrations, which could occur particularly when transporting it in vehicles.

TROUBLE SHOOTING

Use this section to help you to try and solve any problems you may have:

PROBLEM	POSSIBLE CAUSES	REMEDIES
Product does not start	Battery pack not properly attached	Attach properly
	Battery pack over-discharged	Remove and charge the battery pack
	Battery pack damaged	Contact our customer service team
	Other electrical defect to the product	Contact our customer service team
Product does not reach full power	Battery pack capacity too low	Remove and charge the battery pack
	Air vents are blocked	Clean the air vents
Poor cutting performance	Accessory is worn	Replace with a new one
	Accessory not suitable for intended operation	Use suitable accessory
Product suddenly stops	Product overloaded	Remove the product from the workpiece and switch it on again
	Battery pack over-discharged	Remove and charge the battery pack
	Battery pack too hot	Remove the battery pack and let it cool down
Excessive vibration or noise	Accessory is dull / damaged	Replace with a new one
	Sprocket cover / chain loose	Adjust the chain and retighten sprocket cover lock knob

NOTE: IF YOU EXPERIENCE A PROBLEM WITH YOUR TOOL, PLEASE DO NOT ATTEMPT TO OPEN OR REPAIR THE TOOL YOURSELF. DOING SO MAY VOID THE WARRANTY AND COULD CAUSE DAMAGE OR PERSONAL INJURY. IF THE PROBLEM STILL PERSISTS, PLEASE CONTACT US BY REFERRING TO THE SERVICE & SUPPORT INFORMATION ON THE FOLLOWING PAGE.

DECLARATION OF CONFORMITY / PERFORMANCE



Product Code: 74317 (LS C13)

Product Description: Hawksmoor 18V Cordless Mini Pruning Chainsaw

1. Toolstation (company number 04372131)

This declaration of conformity is issued under the sole responsibility of Toolstation

2. Object of the declaration

The object of the declaration described above is in conformity with the relevant Community harmonization legislation:

Supply of Machinery (Safety) Regulations 2008

Electromagnetic Compatibility Regulations 2016

Noise Emission in the Environment by Equipment for use Outdoors Regulations 2001

The Restriction of the Use of Certain Hazardous Substances in Electrical and Electronic Equipment Regulations 2012

Noise Emission in the Environment by Equipment for use Outdoors Regulations 2001

Measured Sound Power Level: 87.9 dB(A)

Guaranteed Sound Power Level: 97 dB(A)

3. References to the relevant standards used or references to the specifications in relation to which conformity is declared:

BS EN 62841-1, BS EN ISO11680-1, BS EN ISO 12100, BS EN60335-1, BS EN 60335-2-29, BS EN 62233, BS EN 55014-1, BS EN 55014-2, BS EN 61000-3-2, BS EN 61000-3-3

4. Additional information:

Signed for and on behalf of Toolstation Limited

ENVIRONMENTAL INFORMATION



The symbol on the product or its packaging indicates that this product must not be disposed of with your other household waste. Instead, it is your responsibility to dispose of your waste equipment by handing it over to a designated collection point for the recycling of waste electrical and electronic equipment. The separate collection and recycling of your waste equipment at the time of disposal will help conserve natural resources and ensure that it is recycled in a manner that protects human health and the environment. For more information about where you can drop off your waste for recycling, please contact your local authority, or where you purchased your product.

WARRANTY

Toolstation products deliver reliable service for normal, household use in domestic settings. All Toolstation products are individually tested before leaving the factory.

If you are a consumer and you experience a problem with your Toolstation product, which is found to be defective due to faulty materials or workmanship within the Warranty Period, this Toolstation Warranty will cover repair or - at the discretion of Toolstation - replacement with a functionally equivalent Toolstation product.

Your product is under warranty for 2 years from the date of purchase or from date of purchase only for all manuals.

The warranty is subject to the following provisions:

- The warranty does not cover accidental damage, misuse, cabinet parts, knobs, or consumable items.
- The product must be correctly installed and operated in accordance with the instructions contained in this manual.
- It must be used solely for domestic purpose.
- The warranty will be rendered invalid if the product is re-sold or has been damaged by inexpert repair.
- Specifications are subject to change without notice.
- The manufacturer disclaims any liability for the incidental or consequential damages.
- The warranty is in addition to, and does not diminish your statutory or legal rights.

CUSTOMER SUPPORT

www.coreservice.co.uk

Call us +44 01904 947568

Email: support@coreservice.co.uk

Made in China

PRODUCT SUPPORT

In the unlikely event of you needing technical support, replacement part or you believe a repair is needed, please contact us in the first instance by following the steps below.



SCAN ME

STEP 1

Find your proof of purchase and scan this QR code **OR** call our helpline below

STEP 2

Get in touch with our team and receive expert technical support



STEP 3

Our team will arrange collection to repair your product under warranty **OR** an alternative resolution



STEP 4

Your product will be assessed and if required, repaired back to full working order



STEP 5

Your repaired product will be returned to you via courier within 10 days



GET IN TOUCH

 01904 947568

 support@coreservice.co.uk

We recommend you keep the original packaging, if repair is needed.

 Technical support: 9am-5pm, Mon-Fri

 Helpline: 24/7

HAWKSMOOR