

ORIGINAL INSTRUCTION MANUAL



McGregor 1400W HIGH PRESSURE WASHER

7228579(Model: MCEPW14C)

VI:10/24

CAUTION Read the instructions before using the machine

These instructions contain important information that will help you get the best from your pressure washer, ensuring it is assembled correctly and safely. If you need help or have damaged or missing parts, call the Customer Helpline on **0345 605 2062**

AFTER SALES SUPPORT
0345 605 2062
SAN NO.:0321802037ZF

Contents

Safety Information.....	3
Warning Symbols	3
General safety.....	4
Personal safety.....	7
Operating safety.....	8
Maintenance and storage safety.....	11
Intended use.....	12
Service.....	12
Vibration and noise reduction.....	12
Residual risks.....	13
In the Box	15
Assembly.....	16
Preparation.....	18
Operation	19
Maintenance.....	22
Troubleshooting.....	23
Technical Data.....	24
Recycling and Disposal.....	25
Getting Help.....	26
Guarantee.....	27

Produced in China for Argos Limited, London, EC1N 2HT, UK. [Argos \(N.I.\) Ltd](#), Forestside Shopping Centre, Upper Galwally, Belfast, BT8 6FX, UK.
<https://bit.ly/Coreservice-McGregor>



Safety Information

Important - Please read these instructions fully before operating or maintaining

Warning symbols

The following warning symbols appear throughout this manual and indicate the appropriate safety measures you should take when operating and maintaining the pressure washer.



Warning



Read the instruction manual



Conforms to relevant UK regulatory requirements



Conforms to all relevant safety standards.



Wear ear protection.



Disconnect the mains plug immediately if the cable is damaged, has been badly twisted or is completely cut through. Disconnect from mains when the product is left unattended.



WARNING: Never direct discharge stream at persons, animals, the unit or electric components.



Appliance not suitable for connection to the potable water mains. Water that has flown through backflow preventers is considered to be non-potable. The appliance is not intended to be connected to the potable water mains. If necessary, please use only with a water backflow preventer or inlet hose-set approved by IEC 61770.



Double insulation, Class II appliance



Waste Disposal and Environmental Protection. Be environmentally friendly. Return the tool, accessories and packaging to a recycling centre when you have finished with them. Electrical machines do not belong in domestic waste. Take the equipment to a waste disposal site. The plastic and metal parts that are used can be separated out into pure grade, which allows them to be recycled.



Guaranteed sound power level 95dB (A)

IPX5

Protection degree against water



Safety Information

Important - Please read these instructions fully before operating or maintaining

General Safety



WARNING! Read all safety warnings and all instructions. Failure to follow the warnings and instructions may result in electric shock, fire and/or serious injury. Save all warnings and instructions for future reference.

Machines shall not be used by children. Children should be supervised to ensure that they do not play with the machine. This machine can be used by people with reduced physical, sensory or mental capabilities or lack of experience and knowledge if they have been given supervision or instruction concerning use of the machine in a safe way and understand the hazards involved.

- **WARNING:** This machine has been designed for use with the cleaning agent supplied or recommended by the manufacturer. The use of other cleaning agents or chemicals may adversely affect the safety of the machine.
- **WARNING:** High pressure jets can be dangerous if subject to misuse. The adjustable spray lance must not be directed at persons, live electrical equipment or the machine itself.
- **WARNING:** Do not use the machine within range of persons unless they wear protective clothing.
- **WARNING:** Do not direct the adjustable spray



Safety Information

Important - Please read these instructions fully before operating or maintaining

General Safety

lance against yourself or others in order to clean clothes or footwear.

- **WARNING:** Risk of explosion – Do not spray flammable liquids.
- **WARNING:** High pressure cleaners shall not be used by children or untrained personnel.
- **WARNING:** High pressure hoses, fittings and couplings are important for the safety of the machine. Use only hoses, fittings and couplings recommended by the manufacturer.
- **WARNING:** To ensure machine safety, use only original spare parts from the manufacturer or approved by the manufacturer.
- **WARNING:** Water that has flowed through back flow preventers is considered to be non potable.
- **WARNING:** Remove the plug from the socket-outlet during cleaning or maintenance and when replacing parts or converting the machine to another function;
- **WARNING:** Do not use the machine if a supply cord or important parts of the machine are damaged, e.g. safety devices, high pressure hoses, spray gun.
- **WARNING:** Inadequate extension cords can be dangerous. If an extension cord is used, it shall be suitable for outdoor use, and the connection has to be kept dry and off the ground. It is recommended that this is accomplished by means



Safety Information

Important - Please read these instructions fully before operating or maintaining

General safety warnings

of a cord reel which keeps the socket at least 60 mm above the ground.

- **WARNING:** Ensure that any exhaust emissions are not in the vicinity of air intakes.
- **WARNING:** Always switch off the mains disconnecting switch when leaving the machine unattended.
- If using detergents with the high pressure, make sure the detergents is recommended by the manufacturer. The use of other detergents or chemicals may compromise the safety of the appliance. The improper use of detergents can cause severe injuries or toxication. Store detergents away from the reach of children.

IMPORTANT!

- Never use the machine while people, especially children or pets are nearby. Keep in mind that the operator or user is responsible for accidents or hazards occurring to other people or their property.
- Don't use the machine without firstly reading the instruction sheet.
- Do not use the machine within range of persons unless they wear protective clothing.



Safety Information

Important - Please read these instructions fully before operating or maintaining

Personal safety



WARNING!

- Risk of fatal injury!

Use special care when cleaning tyres. Vehicle tyres/tyre valves may become damaged or burst when handled improperly. First signs of damage include discolorations on the tyre. Damaged vehicle tyres/tyre valves pose a life-threatening risk. Keep the adjustable spray lance at a distance of at least 30 cm!

- The appliance is not designed for connecting to tap water. If necessary, please use only with a water backflow preventer or inlet hose-set approved by IEC 61770.
- Risk of injury, do not direct discharge stream at persons.
- High-pressure adjustable spray lance can be dangerous if subject to misuse. The adjustable spray lance must not be directed at persons, animals, electrical equipment or the appliance itself.
- Know how to stop the product and bleed pressure quickly, be thoroughly familiar with the controls.
- Stay alert -watch what you are doing.
- Do not operate the product when fatigued or under the influence of alcohol or drugs.
- Keep operating area clear of all persons.



Safety Information

Important - Please read these instructions fully before operating or maintaining

Personal safety

- Do not overreach or stand on unstable support. Keep good footing and balance at all times.
- Always wear appropriate personnel protection equipment (PPE) for high pressure cleaners in operation, e.g. safety boots, safety gloves, safety helmets with visors, hearing protection etc. which shall be worn while operating the equipment
- The operator or user is responsible for accidents or damages to other people or their property.

Operating Safety

WARNING!

- For safety reasons, high pressure hoses, valves and couplings must be used with unit. The new hose-sets supplied with the appliance are to be used. Old hose-sets should not be reused.
- High-pressure hose fittings and couplings are important for the safety of the appliance. Use only hose fittings and couplings recommended by the manufacturer.
- The electric supply connection should be made by a qualified electrician and comply with IEC 60364-1. It is recommended that the electric supply to this machine should include either a residual current device that will interrupt the



Safety Information

Important - Please read these instructions fully before operating or maintaining

Operating Safety

supply if the leakage current to earth exceeds 30 mA for 30 ms or a device that will prove the earth circuit.

- Disconnect from the electrical power supply before carrying out user maintenance.
- Do not use the machine if a supply cord or important parts of the machine are damaged, e.g. safety devices, high pressure hoses, spray gun.
- If an extension cable is used, the plug and socket outlet must be of watertight construction.
- If the supply cord is damaged, it must be replaced by the manufacturer or its service agent or a similarly qualified person in order to avoid a hazard.
- The PVC or polychloroprene sheathed power cord or extension cables (H05VV-F) are acceptable for use at temperatures at or above 0 °C.
- Always switch off the mains disconnecting switch when leaving the machine unattended.
- Never carry the appliance by the cable or the hose. Do not carry the equipment with your finger on the ON/OFF switch when it is connected to the mains.
- Remove the plug from the plug socket if you are not using the equipment, when transporting it or when it is left unattended, when checking the equipment, cleaning it or removing blockages, when undertaking maintenance work or chang-



Safety Information

Important - Please read these instructions fully before operating or maintaining

Operating Safety

ing accessories, if the power or extension cable is damaged, after contact with foreign bodies, or in the event of abnormal vibration.

- Do not use the appliance near flammable liquids or gases. In case of non-observance, there is a risk of fire or explosion.
- Ensure that the mains voltage matches the information on the label.
- Before each use, check the equipment, power cable and plug for damage to minimise risk of electric shock.
- Damaged cables, coupling and plugs or connecting leads that are not compliant with specifications are not to be used. Remove the plug from the plug socket immediately in case of damage or cutting through of the mains cable.
- Do not use the appliance when the switching action of the ON/OFF switch is impaired. Have damaged switches replaced at our Service Centre.
- Do not overload your appliance. Work only within the indicated range of performance. For heavy work, do not use a machine with insufficient power. Do not use your equipment for purposes other than those specified.



Safety Information

Important - Please read these instructions fully before operating or maintaining

Maintenance and storage safety



WARNING!

- Retrofitting or making any unauthorised changes to the machine, as well as the use of unapproved parts will invalidate your warranty.
- Do not attempt to repair the appliance yourself. All work not indicated in these instructions is to be carried out only by service stations authorised by us.
- Store the appliance in a dry location and out of reach of children.
- Handle the appliance with care. Keep the appliance clean for safe and more efficient working. Follow the maintenance directions.

Maintenance and storage safety

- The appliance may be damaged by frost. There is always residual water left inside the high-pressure washer and in the pump. Do not store the machine at temperatures below freezing point in order to avoid frost damage.

This high-pressure cleaner is designed for domestic use only:

- To clean machines, vehicles, buildings, tools, facades, terraces, garden equipment etc. Using a adjustable spray lance (and detergents if required).



Safety Information

Important - Please read these instructions fully before operating or maintaining

Intended Use (continued)

- To be used only with accessories, replacement parts and detergents approved by McGREGOR. Observe the instructions provided with these detergents.
- Any use of the machine that deviates from its intended use and is not included in these instructions is considered unauthorised use and will invalidate the warranty.

Service

Have your tool repaired by an authorised service agent. This tool is manufactured in accordance with the relevant safety regulations. To avoid danger, electrical appliances must only be repaired by qualified technicians. Call our customer helpline on 0345 605 2062 for advice.

Vibration and noise reduction

To reduce the impact of noise and vibration emission, limit the operating time, use low-vibration and low-noise operating modes, and wear personal protective equipment. Take the following points into account to minimise the vibration and noise exposure risks:

- Only use the product as intended by its design and these instructions.



Safety Information

Important - Please read these instructions fully before operating or maintaining

- Ensure that the product is in good condition and well maintained.
- Use correct attachments for the product and ensure they are in good condition.
- Keep tight grip on the handles/grip surface.
- Maintain this product in accordance with these instructions and keep it well lubricated (where appropriate).
- Plan your work schedule to spread any high vibration tool use across a longer period of time.

Residual risks

Even if you are operating this product in accordance with all the safety requirements, potential risks of injury and damage remain. The following dangers can arise in connection with the structure and design of this product:

- Health defects resulting from vibration emission if the product is being used over long periods of time or not adequately managed and properly maintained.
- Injuries and damage to property due to broken cutting attachments or the sudden impact of hidden objects during use.
- Danger of injury and property damage caused by flying objects.
- Prolonged use of this product exposes the operator to vibrations and may produce 'white finger' disease. In order to reduce the risk, please wear



Safety Information

Important - Please read these instructions fully before operating or maintaining

Residual risks (continued)

- gloves and keep your hands warm. If any of the 'white finger' symptoms appear, seek medical advice immediately. 'White finger' symptoms include: numbness, loss of feeling, tingling, pricking, pain, loss of strength, changes in skin colour or condition. These symptoms normally appear in the fingers, hands or wrists. The risk increases at low temperatures.

In the Box

Parts

1. High pressure washer
2. Cable storage
3. Gun storage
4. Handle
5. High pressure hose
6. Adjustable spray lance
7. Extension lance
8. Spray gun
9. Water inlet connector
10. Instruction manual
11. ON/OFF switch
12. Water outlet
13. Outlet hose lock button

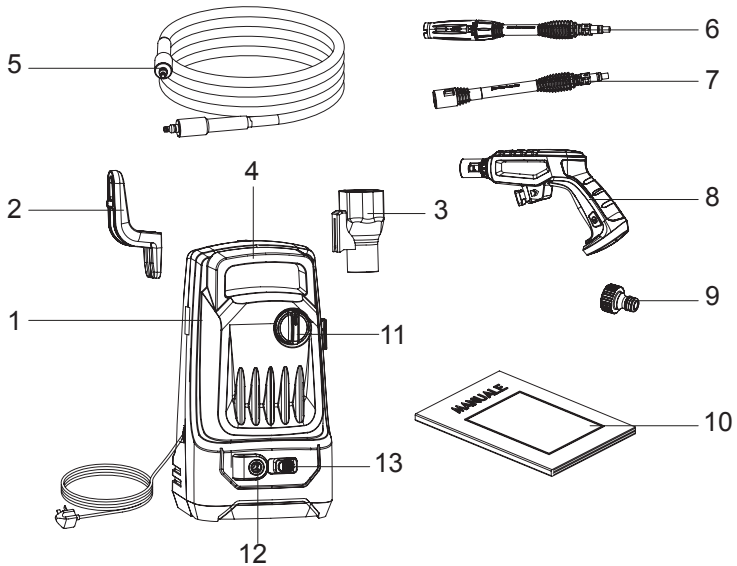

If there are any parts missing, please call the customer helpline on 0345 605 2062

Assembly

Preparing to assemble the pressure washer



IMPORTANT!

- Remove all parts of the pressure washer from the box and carefully remove all packaging. Take care not to lose any instructions which may be affixed to the parts. These provide important information which will be required while assembling the pressure washer.
- Keep all packaging until the pressure washer is fully assembled and has been operated successfully.
- Always recycle the packaging in accordance with local recycling schemes.

Step 1 - Assemble the pressure washer

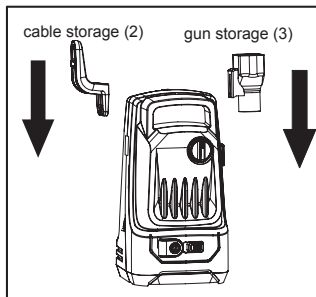

Fix the cable storage (2) and gun storage (3) onto the machine.

Assembly

Step 2 - Fit the high pressure hose to the water outlet

WARNING! Always wear safety gloves when doing any work on the pressure washer.

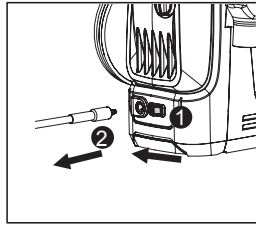
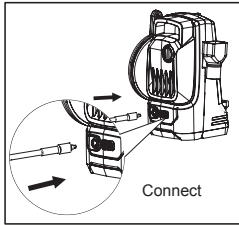

Connect: Connect the high pressure hose(5) to water outlet(12).

Remove: Pull the button ① and then remove high pressure hose to the machine's water outlet ②.

Step 3 - Fit the lance to spray gun

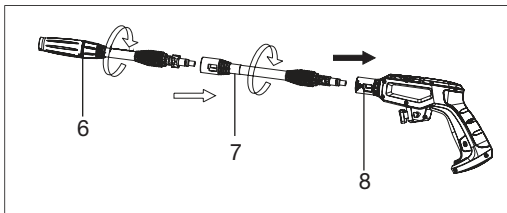

Firstly, insert the extension lance(7) to the spray gun(8) and twist 1/4 turn to lock in position. Then repeat the operation to assemble the spray lance(6) onto the extension lance.

Top tip: Check that it is secured in place.

Step 4 - Connect and remove the high pressure hose to the spray gun

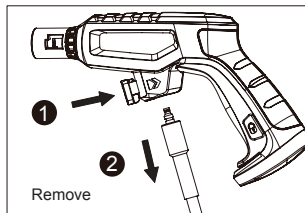
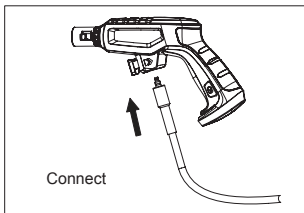

Connect: Connect the high pressure hose firmly onto the spray gun.

Remove: Push the release button ① and pull out the high pressure hose ②.

Preparation

Step 1 - Assemble water inlet adapter.

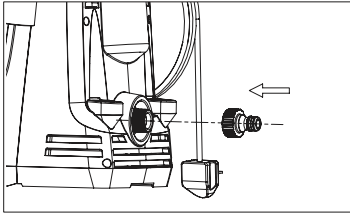

Attach the water inlet connector to the machine's water inlet. Hand tighten only.

Step 2 - Connect garden hose and water inlet adapter.

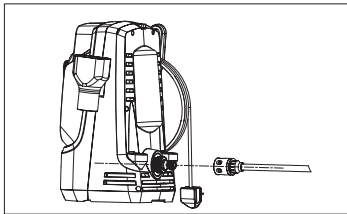

Attach the hose with a quick connect coupling (not included) to water inlet connector.

Step 3 - Connect garden hose and water supply.

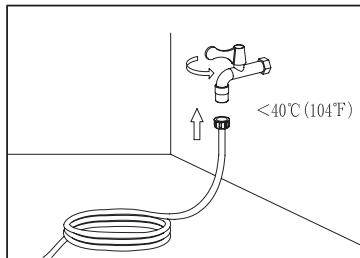

Attach garden hose to water supply and turn water on.

Preparation

Step 4 - Connect to socket

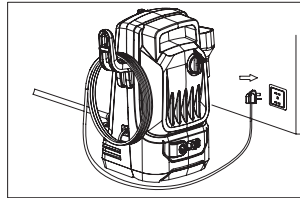
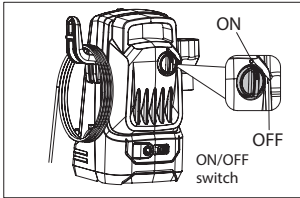

Make sure the ON/OFF switch is in the OFF position and your hands and plug are dry. Connect the plug to the mains socket.

Top tip: We recommend the use of a RCD safety protection device(Not supplied).

Operation

Step 1 - Starting



WARNING!

Wear suitable clothing, ear and eye protection when working with the equipment. Ensure that the equipment is functional before each use. Ensure that the mains voltage value matches the label on the equipment. Check the safe condition of the machine:

- Check for visual defects.

- Check that all parts of the machine have been securely fitted.

- Check that the water connector and the high-pressure pipes are tight.

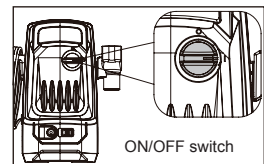
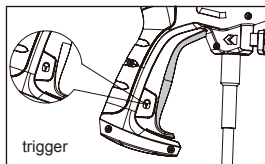
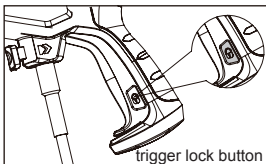

1. Place the high pressure washer on level ground. Stand in a secure and stable position.
2. Unlock the safety trigger on the spray gun and press the trigger until there is a steady stream of water. Further, it will take some time to vent the air from the hose after you press the trigger.
3. Set the ON/OFF switch to ON.

Operation

Step 2 - Stopping

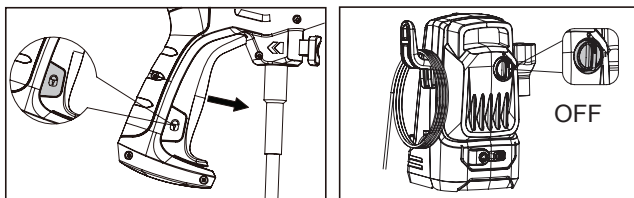

1. Release the trigger and engage the safety lock.
2. Set the ON/OFF switch to OFF.
3. Close the water supply.

Step 3 – Using the high pressure lance



WARNING!

- Always turn off the machine when changing the high pressure lance.
- The spray gun is subjected to a recoil force when the water pressure is discharged. Make sure that you have a firm footing and are holding the spray gun and spray lance with both hands.

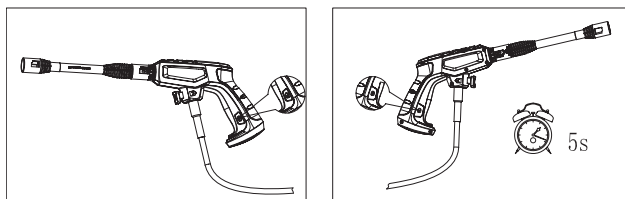

1. Unlock the safety button and press the trigger on the handheld spray lance.
2. Hold the lance and the spray gun firmly with both hands. Be aware of the recoil when switching on the high pressure washer.
3. Press the trigger on the spray gun.

- It takes approximately 5 seconds to release the high pressure.

Note: Clogging of the spray tips causes the pump pressure to be too high and cleaning is immediately required. You can clean the spray tips by the supplied cleaning pin into the tip to remove deposits.

Operation

Step 4 – Using the high pressure lance (continued)



CAUTION!

- Adjustable spray lance is very aggressive. Do not adjust while spraying. Switch the machine off when interrupting your work for extended periods of time.
- The high-pressure pump starts running once you operate the hand-held spray gun. The high-pressure pump stops running once you release the trigger on the hand-held spray gun.

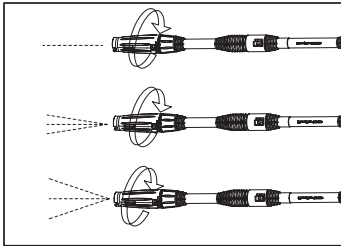

3. Use with adjustable spray lance, 180 degree rotation of the nozzle. It takes a couple of seconds for the spray to adjust to setting

Without turning the gun, adjust the spray to desired angle by turning the nozzle with marking as shown.

Maintenance

Overview of cleaning



WARNING! Always switch the product off, unplug from the power socket and let the product cool down before performing inspection, maintenance and cleaning work!

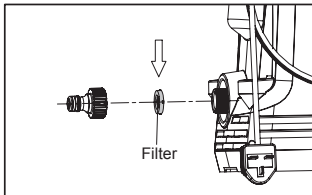

- After every use wipe the machine with a slightly damp cloth. Do not clean the machine using a high-pressure water jet.
- Clean the high-pressure adjustable spray lance. The pressure washer is equipped with a water filter to protect the pump. If the filter is not kept clean, the water flow to the machine will be restricted and the pump may be damaged. To clean water filter, remove inlet adapter and get the filter out.
- Rinse filter until it is free of debris and blockage.
- Replace the filter and inlet adapter.

Clearing of Limescale

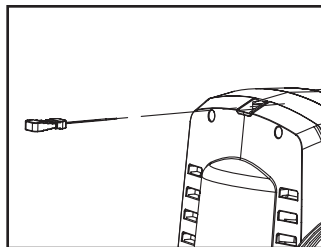
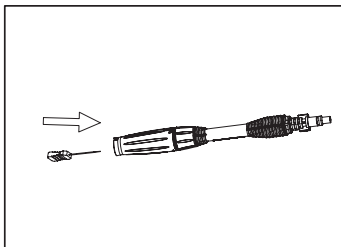

Over a period of time, limescale may build up on your lance outlet, use the nozzle cleaning pin to clean this away.
The nozzle pin can be found in the back of the machine.



WARNING! Please keep the nozzle pin away from children.

Storing

Frost can damage your pressure washer that has not been completely emptied of water. The machine should be stored in a frost free room.
Do not kink high pressure hose.

Troubleshooting

General troubleshooting



WARNING!

- Only perform the steps described within these instructions! All further inspection, maintenance and repair work must be performed by an authorised service centre or a similarly qualified specialist if you cannot solve the problem yourself!
- Always turn off the machine and remove the plug before making any adjustments.

Problem	Possible cause	Solution
1. No power	<ul style="list-style-type: none">- Check the plug socket, cable, line and plug.- Any of the parts are defective, such as ON/OFF switch / motor etc.	<ul style="list-style-type: none">- Connect to mains socket.- Please contact service centre.
2. The high pressure washer operates intermittently.	<ul style="list-style-type: none">- Power cable is damaged.- Internal loose electrical connection.- ON/OFF switch defective.	<ul style="list-style-type: none">- Please contact service centre.
3. No or only little pressure is built up.	<ul style="list-style-type: none">- Check if there is any air in the system.- Check all inlet pipes leading to the pump for leaks or the hose is blocked or there is a kink in the pipe- Check the setting on the hand-held spray gun.	<ul style="list-style-type: none">- If so, please ventilate the machine! Run the machine without the high-pressure hose connected until water starts leaking without bubbles. Re-attach the high-pressure hose.- Follow the operation instructions.
4. Pressure varies	<ul style="list-style-type: none">- Check the high pressure adjustable spray lance.- Check the water inlet pressure.	<ul style="list-style-type: none">- If blocked, clean it with pin.
5. Machine is leaking.	Machine is leaking.	Please contact the service centre.
6. Motor is running but no pressure is built up	You might have air locked in the hose.	Turn off machine, disconnect hose, run water through and connect again. If the problem continues then please contact the customer service centre.

Technical Data

Technical data table

Model	MCEPW14C
Voltage	230-240V~ /50Hz
Input power	1400W
Rated pressure	6 MPa
Max. pressure	9 MPa
Rated flow	5 l/min
Max. flow	6.5 l/min
Max. input water pressure	0.6 MPa
Inlet T _{max}	40°C
Net weight	5 kg
Hose length	3 m
Cable length	5 m
Guaranteed sound power level	95 dB (A)
Measured sound power level	90.41 dB(A), K= 2.66 dB(A)
Measured sound pressure level	78dB(A), K=3dB(A)
Vibration	1.5 m/s ² , K=1.5 m/s ²
Protection degree against water	IPX5
Insulation protection class	II

The sound values have been determined according to noise test code given in EN 60335-2-79, using the basic standards EN ISO 3744 and may be used for comparing one tool with another. The declared vibration value may also be used in a preliminary assessment of exposure.



WARNING! The vibration emission value during actual use of the tool can differ from the declared value depending on the ways in which the tool is used. Identify safety measures to protect the operator that are based on an estimation of exposure in the actual conditions of use (taking account of all parts of the operating cycle such as the times when the tool is switched off and when it is running idle in addition to the trigger time).

The sound intensity level for the operator may exceed 85dB(A) and ear protection measures are necessary.

Recycling and Disposal

Recycling and disposal



Recycle unwanted materials instead of disposing of them as waste. All tools, hoses and packaging should be sorted, taken to the local recycling centre and disposed of in an environmentally safe way.

Recycle rather than dispose of unwanted material in landfill whenever possible. The machine must be delivered in rigid packaging to avoid damage during transportation. The packaging and the machine itself are manufactured from recyclable materials and should be disposed of accordingly.

Only dispose of electrical/electronic/battery items in separate collection schemes, which cater for the recovery and recycling of materials contained within. Your cooperation is vital to ensure the success of these schemes and for the protection of the environment.

Recycle packaging where facilities exist.

This symbol is known as the Crossed out Wheeie Bin Symbol. When this symbol is marked on a product or battery, it means that it should not be disposed of with your general household waste. Some chemicals contained within electrical/electronic products or batteries can be harmful to health.

Getting Help

Customer Helpline 0345 605 2062

Our dedicated UK based customer service centre is open 7 days a week to assist you with assembly, parts queries and technical support. We are open during office hours. Our experts are here to get you back enjoying your garden in no time.

Calling our service does not affect your statutory rights.

UK/N.I. 0345 605 2062

Guarantee

Dear Customer,

In the unlikely event that your product develops a fault, please contact our contact our customer service team on the telephone number shown below.

1. The guarantee terms below cover additional guarantee rights and do not affect your statutory warranty rights. Claims must be accompanied by proof of purchase. This must be in the form of a sales receipt or bank statement and must show that the product has been purchased within 2 years prior to the claim, from the retailer that it was originally sold to.

2. Our guarantee covers problems caused by material or manufacturing defects, and will result in the repair of these defects or replacement of the product with a like for like or similar product. Please note that our product have not been designed for use in commercial, trade or industrial applications. Consequently, the guarantee is invalidated if the equipment is used in commercial, trade or industrial applications or for other equivalent activities.

3. The following are also excluded from our guarantee :

- A. Faults due to accidents, customer misuse or unauthorised repairs
- B. Consumable parts such as detergent bottle, turbo lance, adjustable spray lance and nozzle pin
- C. Failure due to lack of routine maintenance.
- D. Failure as a result of not using the equipment in accordance with the manual and safety instructions
- E. The adjustment of cables, pumps, or lances.

4. The guarantee is valid for a period of 2 years starting from the purchase date of the product. Guarantee claims should be submitted before the end of the guarantee period within two weeks of the defect being noticed. No guarantee claims will be accepted after the end of the guarantee period. The original guarantee period remains applicable to the product even if repairs are carried out or parts are replaced. In such cases, the work performed or parts fitted will not result in an extension of the guarantee period, and no new guarantee will become active for the work performed or parts fitted. This also applies when an on-site service is used.

5. Please keep your sales receipt in a safe place. If is covered by our guarantee your product will either be repaired under the terms of guarantee or we will send you a replacement product. This product may be re-conditioned or like for like replacement.