

POWERBASE

34cm 40V Cordless
Lawn Mower 660832

Instruction Manual

IMPORTANT!
Please read these
instructions fully before
starting assembly.



These instructions contain important information that will help you get the best from your product, ensuring it is assembled correctly and safely. If you need help or have damaged or missing parts, call the Customer Helpline on 01904 727 509.

Contents

General safety warnings	3
Intended use	11
Warning symbols	16
In the box	19
Assembling the lawn mower	20
Operation	24
Maintenance and storage	31
Troubleshooting	34
Technical data	35
Havs	36
Disposal	36
Getting help	36
Warranty	37

General Safety Warnings



WARNING! Read all safety warnings, instructions, illustrations and specifications provided with this power tool.

Failure to follow all instructions listed below may result in electric shock, fire and/or serious injury.

Save all warnings and instructions for future reference.

The term “power tool” in the warnings refers to your mains-operated (corded) power tool or battery-operated (cordless) power tool.

Work area safety

- **Keep work area clean and well lit.** Cluttered or dark areas invite accidents.
- **Do not operate power tools in explosive atmospheres, such as in the presence of flammable liquids, gases or dust.** Power tools create sparks which may ignite the dust or fumes.
- **Keep children and bystanders away while operating a power tool.** Distractions can cause you to lose control.

Electrical safety

- **Power tool plugs must match the outlet. Never modify the plug in any way. Do not use any adapter plugs with earthed (grounded) power tools.** Unmodified plugs and matching outlets will reduce risk of electric shock.
- **Avoid body contact with earthed or grounded surfaces, such as pipes, radiators, ranges and refrigerators.** There is an increased risk of electric shock if your body is earthed or grounded.
- **Do not expose power tools to rain or wet conditions.** Water entering a power tool will increase the risk of electric shock.
- **Do not abuse the cord. Never use the cord for carrying, pulling or unplugging the power tool. Keep cord away from heat, oil, sharp edges or moving parts.** Damaged or entangled cords increase the risk of electric shock.
- **When operating a power tool outdoors, use an extension cord suitable for outdoor use.** Use of a cord suitable for outdoor use reduces the risk of electric shock.
- **If operating a power tool in a damp location is unavoidable, use a residual current device (RCD) protected supply.** Use of an RCD reduces the risk of electric shock.

Personal safety

- **Stay alert, watch what you are doing and use common sense when operating a power tool. Do not use a power tool while you are tired or under the influence of drugs, alcohol or medication.** A moment of inattention while operating power tools may result in serious personal injury.
- **Use personal protective equipment. Always wear eye protection.** Protective equipment such as a dust mask, non-skid safety shoes, hard hat or hearing protection used for appropriate conditions will reduce personal injuries.
- **Prevent unintentional starting. Ensure the switch is in the off-position before connecting to power source and/or battery pack, picking up or carrying the tool.** Carrying power tools with your finger on the switch or energising power tools that have the switch on invites accidents.
- **Remove any adjusting key or wrench before turning the power tool on.** A wrench or a key left attached to a rotating part of the power tool may result in personal injury.
- **Do not overreach. Keep proper footing and balance at all times.** This enables better control of the power tool in unexpected situations.
- **Dress properly. Do not wear loose clothing or jewellery. Keep your hair and clothing away from moving parts.** Loose clothes, jewellery or long hair can be caught in moving parts.

- **If devices are provided for the connection of dust extraction and collection facilities, ensure these are connected and properly used.** Use of dust collection can reduce dust-related hazards.
- **Do not let familiarity gained from frequent use of tools allow you to become complacent and ignore tool safety principles.** A careless action can cause severe injury within a fraction of a second.

Power tool use and care

- **Do not force the power tool. Use the correct power tool for your application.** The correct power tool will do the job better and safer at the rate for which it was designed.
- **Do not use the power tool if the switch does not turn it on and off.** Any power tool that cannot be controlled with the switch is dangerous and must be repaired.
- **Disconnect the plug from the power source and/or the battery pack from the power tool, before making any adjustments, changing accessories, or storing power tools.** Such preventive safety measures reduce the risk of starting the power tool accidentally.
- **Store idle power tools out of the reach of children, and do not allow persons unfamiliar with the power tool or these instructions to operate the power tool.**

Power tools are dangerous in the hands of untrained users.

- **Maintain power tools. Check for misalignment or binding of moving parts, breakage of parts and any other condition that may affect the power tools operation. If damaged, have the power tool repaired before use.** Many accidents are caused by poorly maintained power tools.
- **Keep cutting tools sharp and clean.** Properly maintained cutting tools with sharp cutting edges are less likely to bind and are easier to control.
- **Use the power tool, accessories and tool bits, etc. in accordance with these instructions, taking into account the working conditions and the work to be performed.** Use of the power tool for operations different from those intended, could result in a hazardous situation.
- **Keep handles and grasping surfaces dry, clean and free from oil and grease.** Slippery handles and grasping surfaces do not allow for safe handling and control of the tool in unexpected situations.

Battery tool use and care

- **Recharge only with the charger specified by the manufacturer.** A charger that is suitable for one type of battery pack may create a risk of fire when used with another battery pack.

- **Use power tools only with specifically designated battery packs.** Use of any other battery packs may create a risk of injury and fire.
- **When a battery pack is not in use, keep it away from other metallic objects, like paper clips, coins, keys, nails, screws or other small metallic objects, that can make a connection from one terminal to another.** Shorting the battery terminals together may cause burns or a fire.
- **Under abusive conditions, liquid may be ejected from the battery; avoid contact. If contact accidentally occurs, flush with water. If liquid contacts eyes, immediately seek medical help.** Liquid ejected from the battery may cause irritation or burns.
- **Do not use a battery pack or tool that is damaged or modified.** Damaged or modified batteries may exhibit unpredictable behaviour resulting in fire, explosion or risk of injury.
- **Do not expose a battery pack or tool to fire or excessive temperature.** Exposure to fire or temperature above 130°C may cause an explosion.
- **Follow all charging instructions and do not charge the battery pack or tool outside the temperature range specified in the instructions.** Charging improperly or at temperatures outside the specified range, may damage the battery and increase the risk of fire.

Service

- **Have your power tool serviced by a qualified repair person using only identical replacement parts.** This will ensure that the safety of the power tool is maintained.
- **Never service damaged battery packs**
Service of battery packs should only be performed by the manufacturer or authorised service providers.

Safety warnings for the battery pack



WARNING! Read all safety warnings and all instructions. Failure to follow the warnings and instructions may result in electric shocks, fire and/or serious injury.

Save all warnings and instructions for future reference.

- Do not dismantle, open or shred cells on battery pack.
- Do not short-circuit a battery pack. Do not store battery packs haphazardly in a box or drawer where they may short circuit each other or be short-circuited by conductive materials. When the battery pack is not in use, keep it away from other metallic objects, like paper clips, coins, keys, nails, screws or other small metal objects that can make a connection from one terminal to another. Shorting the battery terminals together may cause burns or a fire.

- Do not expose battery packs to heat or fire. Avoid storage in direct sunlight.
- Do not subject battery packs to mechanical shock.
- In the event of the battery leaking, do not allow the liquid to come into contact with the skin or eyes. If contact has been made, wash the affected area with copious amounts of water and seek medical advice.
- Seek medical advice immediately if a cell or battery pack has been swallowed.
- Keep the battery pack clean and dry.
- Wipe the battery pack terminals with a clean dry cloth if they become dirty.
- Battery packs need to be charged before use. Always refer to this instruction manual and use the correct charging procedure.
- Whilst the battery pack is being charged, refrain from any maintenance.
- After extended periods of storage, it may be necessary to charge and discharge the battery pack several times to obtain maximum performance.
- The battery pack gives its best performance when it is operated at normal room temperature ($20^{\circ}\text{C} \pm 5^{\circ}\text{C}$).
- When disposing of battery packs, keep battery packs of different electrochemical systems separate from each other.
- Recharge only with the charger specified by the manufacturer. Do not use any

charger other than that specifically provided for use with the equipment. A charger that is suitable for one type of battery pack may create a risk of fire when used with another battery pack.

- Do not use any battery pack which is not designed for use with the equipment.
- Keep the battery pack out of the reach of children.
- Retain the original product literature for future reference.
- Remove the battery from the equipment when not in use.
- Dispose of the battery properly.

Safety warnings for the battery charger



WARNING! Read all safety warnings and all instructions. Failure to follow the warnings and instructions may result in an electric shock, fire and/or serious injury.

Save all warnings and instructions for future reference.

- This lawn mower is not intended for use by persons (including children) with reduced physical, sensory or mental capabilities, or lack of experience and knowledge, unless they have been given supervision or instruction concerning use of the appliance by a person responsible for their safety.

- Children should be supervised to ensure that they do not play with the appliance.
- Before charging, read the instructions.
- After charging, disconnect the battery and charger from the mains supply. Then remove the chassis connection and then the battery connection.
- Do not charge a leaking battery.
- Do not use chargers for purposes in which they are not designed for.
- Before charging, ensure your charger matches the local AC supply.
- Charge the battery indoors and only use in dry conditions.
- The charging device must be protected from moisture.
- Do not use the charging device in the open.
- Shorting the battery terminals together may cause burns or a fire.
- Respect the polarity “+/-“ when charging.
- Do not open the unit and keep out of the reach of children.
- Do not charge the batteries of other manufacturers or ill-suited models.
- Ensure that the connection between the battery charger and battery is correctly positioned and is not obstructed by foreign bodies.
- Ensure the slot for the batter charger is clear and unobstructed. Store in a dry and frost-free place to protect against dirt and humidity.

- When charging batteries, ensure that the battery charger is in a well-ventilated area and away from flammable materials. Batteries can heat up quickly whilst charging. Ensure that batteries and chargers are not left unsupervised during charging.
- Do not recharge non-rechargeable batteries, as they can overheat and break.
- Longer life and better performance can be obtained if the battery pack is charged when the air temperature is between 18°C and 24°C. Do not charge the battery pack in air temperatures below 0°C, or above 45°C. This is important as it can prevent serious damage to the battery pack.
- Charge only the battery pack of the same model provided by the manufacturer, and those of models recommended by the manufacturer.

Cordless lawn mower safety warnings

- **Do not use the lawn mower in bad weather conditions, especially when there is a risk of lightning.** This decreases the risk of being struck by lightning.
- **Thoroughly inspect the area for wildlife where the lawn mower is to be used.** Wildlife may be injured by the lawn mower during operation.
- **Thoroughly inspect the area where the lawn mower is to be used and remove all stones, sticks, wires, bones, and other**

foreign objects. Thrown objects can cause personal injury.

- **Before using the lawn mower, always visually inspect to see that the blade and the blade assembly are not worn or damaged.** Worn or damaged parts increase the risk of injury.
- **Check the grass catcher frequently for wear or deterioration.** A worn or damaged grass catcher may increase the risk of personal injury.
- **Keep guards in place. Guards must be in working order and be properly mounted.** A guard that is loose, damaged, or is not functioning correctly may result in personal injury.
- **Keep all cooling air inlets clear of debris.** Blocked air inlets and debris may result in overheating or risk of fire.
- **While operating the lawn mower, always wear non-slip and protective footwear. Do not operate the lawn mower when barefoot or wearing open sandals.** This reduces the chance of injury to the feet from contact with the moving blade.
- **While operating the lawn mower, always wear long trousers.** Exposed skin increases the likelihood of injury from thrown objects.
- **Do not operate the lawn mower in wet grass. Walk, never run.** This reduces the risk of slipping and falling which may result in personal injury.

- **Do not operate the lawn mower on excessively steep slopes.** This reduces the risk of loss of control, slipping and falling which may result in personal injury.
- **When working on slopes, always be sure of your footing, always work across the face of slopes, never up or down and exercise extreme caution when changing direction.** This reduces the risk of loss of control, slipping and falling which may result in personal injury.
- **Use extreme caution when reversing or pulling the lawn mower towards you. Always be aware of your surroundings.** This reduces the risk of tripping during operation.
- **Do not touch blades and other hazardous moving parts while they are still in motion.** This reduces the risk of injury from moving parts.
- **When clearing jammed material or cleaning the lawn mower, make sure all power switches are off and the battery pack is disconnected.** Unexpected operation of the lawn mower may result in serious personal injury.
- **When clearing jammed material or cleaning the lawn mower, make sure all power switches are off and remove (or activate) the disabling device.** Unexpected operation of the lawn mower may result in serious personal injury.

Intended Use

This lawn mower is designed for domestic lawn mowing only. Use in any other way is considered contrary to the intended use. Compliance with the operation, service and repair, as specified in this manual, also constitutes essential elements of the intended use. Failure to comply can void the warranty.

Warning Symbols

The purpose of safety symbols is to attract your attention to any possible dangers. The safety symbols and their explanations deserve your careful attention and full understanding. The symbol warnings do not, by themselves, eliminate any danger. The instructions and warnings they give are no substitute for proper accident prevention measures.



WARNING: Be sure to read and understand all safety instructions within this operator's manual, including all safety alert symbols, such as '**DANGER**', '**WARNING**', and '**CAUTION**' before using this tool. Failure to follow all instructions listed below may result in electric shock, fire and/or serious personal injury.

SAFETY ALERT SYMBOLS: Indicate **DANGER**, **WARNING**, or **CAUTION**. May be used in conjunction with other symbols or pictographs.

Symbol meanings

This page depicts and describes safety symbols that may appear on this product. Read, fully understand and follow all instructions on the machine before attempting to assemble and operate.



To reduce the risk of injury, please read the instruction manual before operating this lawn mower.

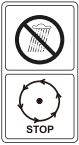

Avoid using the lawn mower in the rain.

Wait until all lawn mower components have completely stopped before touching them.



Keep bystanders away. Objects thrown by the product could hit the user or other bystanders. Always ensure that other people and pets remain at a safe distance from the product when it is in operation.



Beware of sharp blades. Blades continue to rotate after the motor is switched off. Remove disabling device before performing any maintenance tasks.



Guaranteed sound power level value is 96 dB.



Wear ear protection, eye protection and protective gloves (PPE) when using the product.



WEEE symbol. Waste electrical products should not be disposed of with household waste. Please recycle where facilities exist. Check with your local authority or local store for recycling guidelines.



The product complies with the applicable European directives and an evaluation method of conformity for these directives was done.



The product complies with the applicable UK directives and an evaluation method of conformity for these directives was done.

Warning symbols on the battery pack



To reduce the risk of injury, the user must read the instruction manual carefully.



Do not throw into water.



Do not throw on fire.



Do not subject the battery to strong sunlight over long periods of time. Do not leave on a heater (max. 45°C).



Batteries contain Li-ion. Do not dispose of waste batteries in domestic waste. Contact local authority to find out how to dispose of batteries.

Warning symbols on the charger



To reduce the risk of injury, the user must read the instruction manual carefully.



The charger is for indoor use only.



Class II equipment.



Protective 5A limited.



WEEE symbol. Waste electrical products should not be disposed of with household waste. Please recycle where facilities exist. Check with your local authority or local store for recycling advice.



The product complies with the applicable European directives and an evaluation method of conformity for these directives was done.

In the Box

Parts

- A. Lawn mower with upper handle
- B. Grass collection bag
- C. Lower handle
- D. Quick-release clamps (fixed in screw) x 2
- E. Teeth clamps x 2
- F. Quick-release clamps (curved head) x 2
- G. Cable clips x 2
- H. Battery pack
- I. Charger

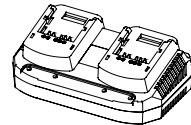
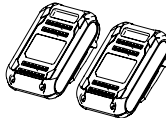
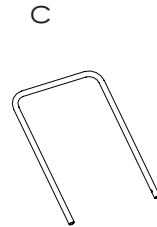
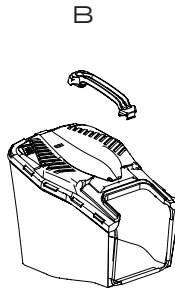
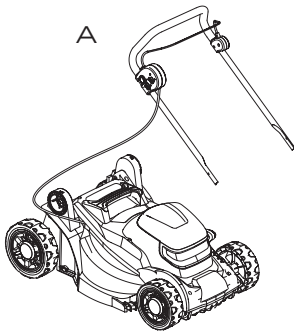

D

E

F

G

H

I

Assembling the Lawn Mower

Parts

1. Switch box
2. Lower handle
3. Carry handle
4. Battery pack tank cover
5. Front wheel
6. Cutting height adjustment lever
7. Rear wheel
8. Grass bag
9. Quick-release clamp
10. Switch lever
11. Top handle

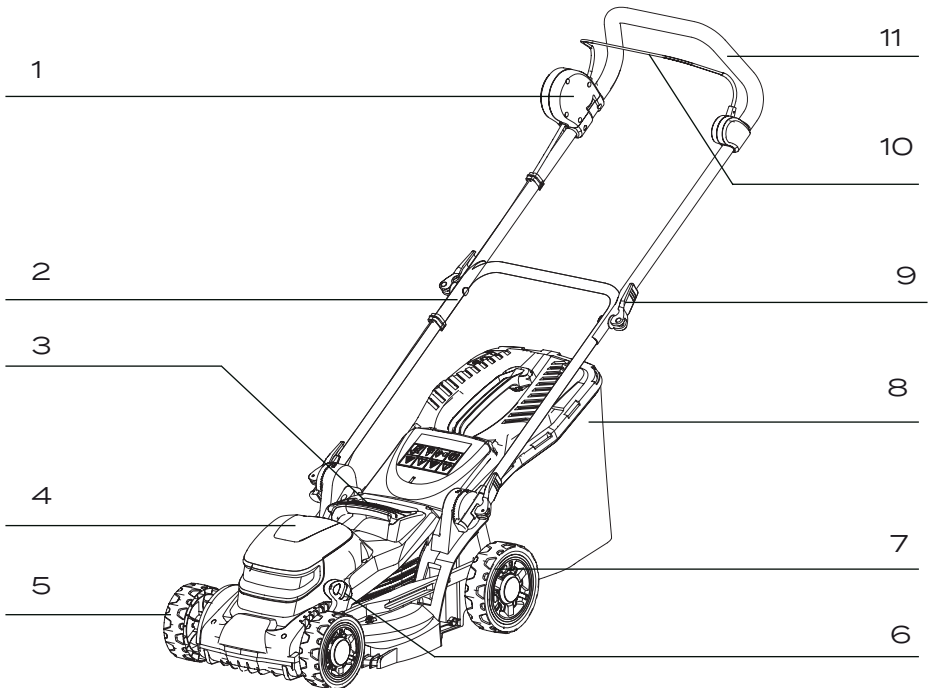



WARNING: Ensure the battery pack is disconnected from the mower before starting assembly.

Attach the lower handle

Attach the two tooth clamps to the lower handle.

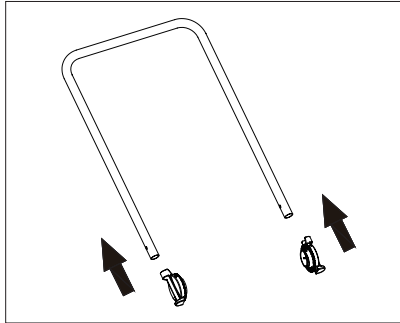

Attach the lower handle to the lawn mower

Install the lower handle to the lawn mower with two quick-release clamps (with fixed in screw). Make sure that the teeth of the fixing gears interlock correctly.

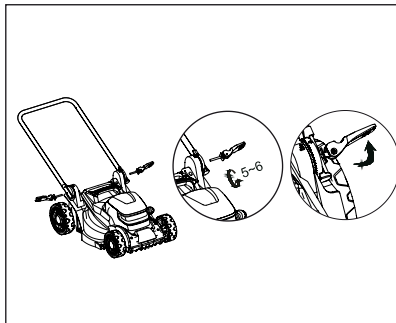

Attach the top handle to the lawn mower

Mount the top handle to the lower handle using two quick-release clamps (screw with curved head).

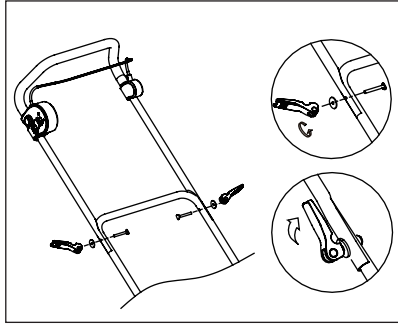

Fitting the cable clip

Ensure that the cable clips supplied are used to fix the cable to the lower handle.

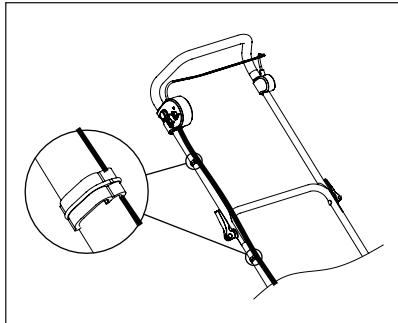

Attach the grass bag

- i. Insert the grass bag handle into the groove of the grass bag.
- ii. Then press the grass bag handle into the clip of the grass bag, and hear “click” to indicate that the handle is in place.
- iii. Attach the grass bag to the frame by fixing the plastic hooks onto the side.

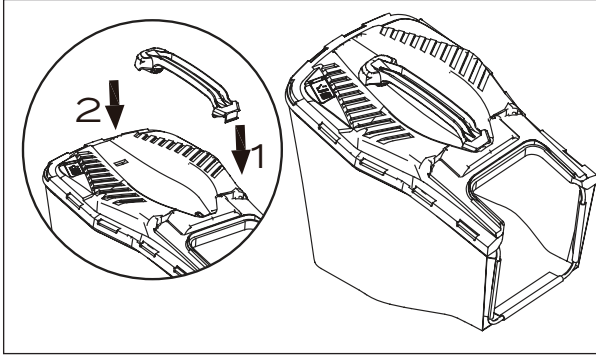

Lift the safety flap with one hand and hook in the grass bag. Release the ejector flap to secure the grass bag in position.

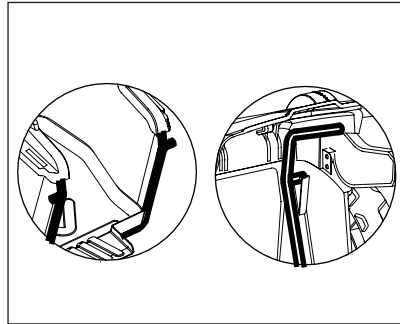
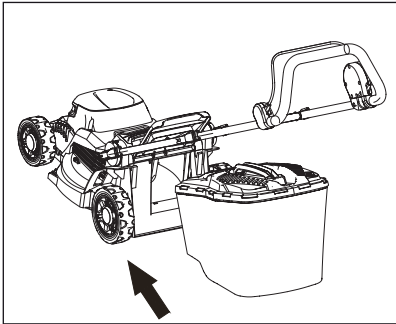

Operation

Charging the battery pack



NOTE: The battery pack comes partly charged. Charge the battery pack prior to first use, ideally at least 60 minutes.

- Always pull out the plug of the charger from the mains before removing or connecting the battery pack to the charger.
- Never charge the battery pack when the ambient temperature is below 0°C or above 45°C.
- Never recharge a battery pack again immediately after rapid charging. This could overcharge the battery pack, thus reducing the lifespan of the battery pack and charger.
- Rest the charger for at least 15 minutes between charging sessions.
- If no battery pack is inserted into the charger and the charger is connected to mains, the charging status LED illuminates red.



NOTE: Always fully charge the two batteries at the same time.

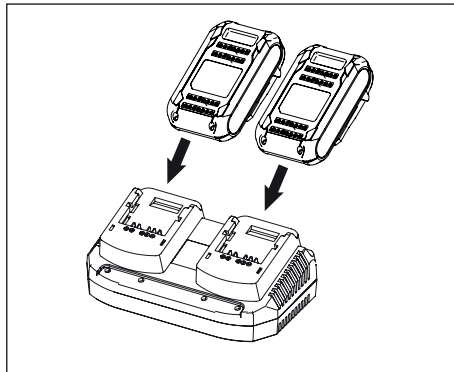

Checking battery capacity

Press the battery capacity level button to check the charging level of the battery pack. The status/remaining charge will be shown on the battery digital display.

Digital display: 100%	Battery pack fully charged
No digital display lights	Battery is flat and needs to be charged

Charge the battery pack before operating when it is at medium or low battery charging level.

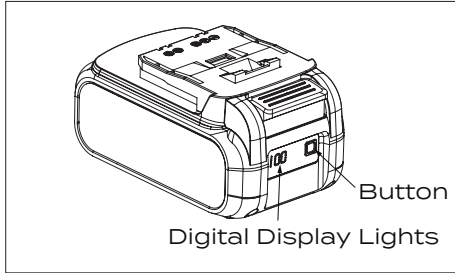

- i. Connect the battery pack to the battery charger.
- ii. Insert the mains plug into the socket. The green charging status LED light will flash. Once the battery pack is completely charged, the green charging status LED will remain still, indicating that the charging process is complete.
- iii. Disconnect the charger from the mains and remove the battery pack from the charger.
- iv. Attach the battery pack back to the product.

Charging status LEDs

Red LED turns on	Charger ready
Green LED flashes	Battery pack charging
Green LED continuously lit (still)	Battery pack fully charged
Red and green LEDs flashing	Battery pack defect
Red and green LEDs continuously lit	Battery pack too cold or warm

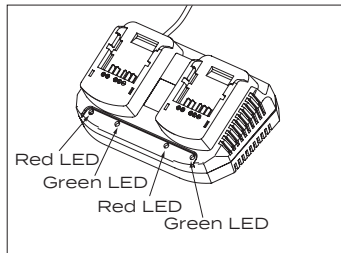

USB- A PORT

The USB-A port is on the top cover of the battery pack. Connect your electric device to the USB-A port on the battery pack using the USB-A cable. Push the button to start charging.

To obtain the best life from the battery

1. Never allow the battery to completely discharge before recharging. The battery pack should be placed on the charger whenever the battery pack is noticeably running down or the lawn mower no longer performs a task it previously performed.
2. Avoid conducting short charges. Make sure that the battery is fully charged each time by allowing the charger to complete its full charging cycle.
3. Avoid allowing loose items like screws or nails, etc. to be stored with battery packs, as these or similar items can short battery packs and cause a fire or explosion.
4. Always unplug the charger when not in use and store in a dry and secure place.
5. Avoid charging or storing your battery in temperatures below 5°C and above 45°C.
6. After use, allow the battery pack to cool down for approximately 30 minutes before attempting to recharge.

Removing and inserting the battery pack

Insert the battery pack

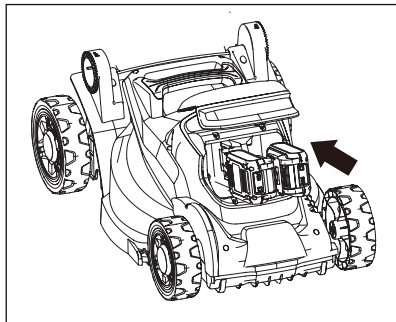

Align the battery pack with its compartment on the lawn mower. Push the battery pack into the tank until you hear a click. This means the battery pack has been locked in position, then close the battery pack tank cover.

Removing the battery pack from the lawn mower

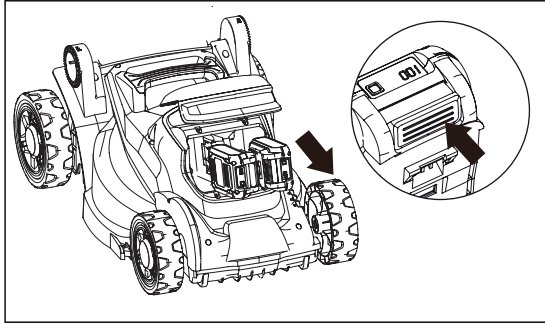

Open the battery pack tank cover. Press the battery pack release button on the battery pack, then pull the battery pack out.

Setting the cutting height

If you wish to change the cutting height, push the adjusting lever first to take it out of the tooth, then push the lever to the desired position.

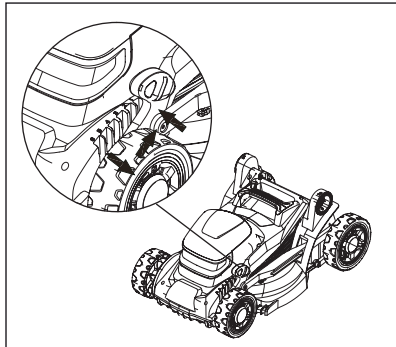

WARNING: Never operate the adjusting handle roughly.

Switching on and off

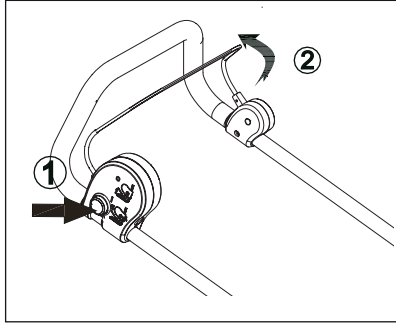

Switch on:

1. Press and hold the safety button on the side of the switch box with one hand.
2. Pull the switch bar towards the handle and hold it with the other hand.
3. Release the safety button.

Switch off:

Release the switch bar.

Operating the lawn mower



WARNING: Ensure the battery pack is disconnected from the mower before making any adjustment, cleaning and maintenance.

Operation on a slope:

Slopes increase the risk of slip-and-fall accidents, which can result in severe injury. Always be sure of your footing on slopes. Operation on slopes requires extra caution. If you feel uneasy on a slope, do not mow it.

Do:

- Mow across the face of slopes, never mow up and down. Exercise extreme caution when changing direction on slopes.
- Watch for holes, ruts, rocks, hidden objects or bumps which could cause you to slip or trip. Tall grass can hide obstacles.

Do not:

- Do not mow near drop-offs, ditches or embankments; you could lose your footing or balance.
- For safety reasons, do not use the mower on gradients exceeding 15°.
- Do not mow on wet grass. Unstable footing could cause you to slip.

Mower overload protection

To prevent overload conditions, do not try to cut too much grass at one time. Slow down your cutting pace or raise the cutting height. Your mower has built-in overload circuit protection. When the mower is overloaded, the mower will stop. Switch the mower off and check to see if grass has collected beneath the deck and clear it if necessary, then restart the mower.

Battery high temperature protection

The battery pack will generate heat during operation. The heat dissipates slower in hot weather. If the battery temperature exceeds more than 70°C during operation, the protection circuit will immediately turn off the mower to protect the battery pack from damage. Release the switch bar, wait until the battery pack cools down and then restart the mower.

Function of full indicator

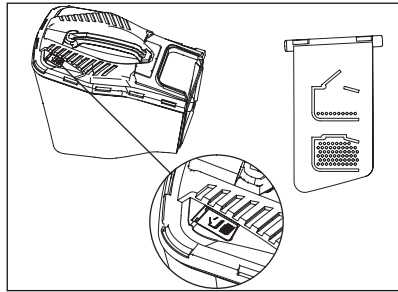

If the grass bag is empty or it is not filled with grass, the grass full indicator will be open.

If the grass bag is filled with grass, the grass full indicator will be closed.

Emptying the grass bag

As soon as the grass bag indicator closes while you are mowing, it is time to empty the grass bag.

NOTE: Before removing the grass bag, switch off the mower, disconnect the battery pack and wait until the blade has come to a complete stop.

To take off the grass bag, use one hand to lift up the safety flap and the other to grab on to the carry handle of the grass bag. The safety flap automatically falls down after removing the grass bag and closes off the rear chute opening. Empty out the grass bag then refit to the mower.

NOTE: If any grass residue is caught in the discharge chute, clean it using a brush. Do not remove grass debris in the mower casing or on the blade by hand or with your feet. Instead, use suitable tools, such as a brush or broom. To ensure that the cut grass can be collected into the grass bag, the discharge opening and inside the mower casing must be cleared of any blockages.

Maintenance and Storage



WARNING: Before performing any maintenance or cleaning work, always ensure that the battery pack/safety key has been removed. Wait until the blade has stopped completely and the machine has cooled down.

Cleaning

Cleaning the product

- Use a soft brush to remove accumulated dust and debris. Wear safety glasses to protect your eyes whilst cleaning.
- Wipe down the product enclosure with a slightly damp cloth. Do not spray the unit with water. Water may destroy the switch unit and the electric motor.

Maintenance

NOTE: Always wear gardening gloves when handling or working near sharp blades.

1. Keep all nuts, bolts and screws tight to ensure that the lawn mower is in a safe working condition.
2. Check the grass bag frequently for wear or deterioration.
3. Examine the lawn mower and replace worn or damaged parts for safety.

Removing/installing the blade

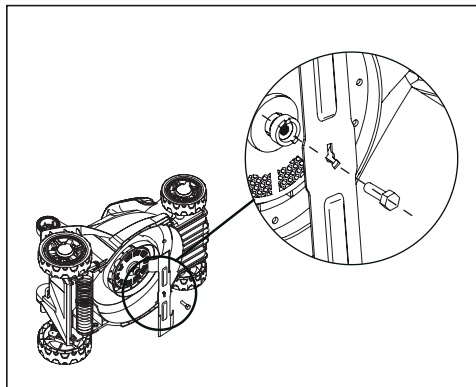

1. Use the correct size wrench to uninstall the blade bolt nut.
2. Wearing heavy-duty gloves, hold the blade still and turn the wrench anti-clockwise to remove the bolt.
3. Fit the replacement blade correctly with the markings facing up and align the pegs, refit the bolt and retighten securely to torque 20N.m.



WARNING: Replace or re-sharpen the mowing blade at the end of the mowing season. Always have the mowing blade re-sharpened or replaced by a recommended service centre.

Unbalanced blades will cause the lawn mower to vibrate violently, which can increase the risk of accidents occurring.

Battery maintenance:

Use the following procedures to achieve the best battery life:

1. Protect the battery against moisture and water.
2. Store the battery only within temperature range of 5°C to 45°C. Do not leave the battery in direct sunlight for extended periods of time.
3. Clean the battery regularly with a soft, clean and dry brush.
4. If you do not use the product for a long time, remember to charge and discharge the battery pack once every 6 months.

Storage and transport

Storage

After cleaning the unit thoroughly, store the lawn mower in a dry room and allow the motor to cool down.

To reduce storage space, the lawn mower can be folded.

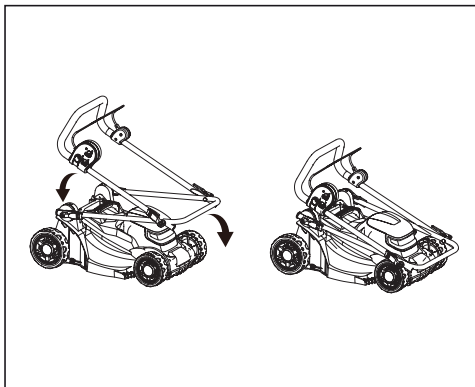

1. Loosen the quick-release lock system on the handles.
2. Fold the handles.

NOTE: Remove the safety key and battery packs. Ensure cables are not trapped when folding/unfolding the handle. If stored vertically, make sure the mower is positioned in a corner so that the blade is facing inwards against a wall, and the lawn mower is secure to prevent it falling over.

Transport

Use the original packaging to ship whenever possible.

Consumable parts

Part No. 660832 Powerbase 34cm 40V Cordless Lawn Mower	Part Name
1052547000	Grass bag
1252799000	Blade

Troubleshooting







WARNING! Before performing any repair work, always ensure that the battery pack has been removed.

WARNING! Always wear heavy-duty gloves when adjusting or cleaning, especially when handling sharp objects.

Fault	Possible cause	Solution
Mower fails to start	Safety key is not inserted	Insert safety key
	Battery is not correctly inserted	Remove battery and reinsert
	Mower standing in high grass	Start motor on shorter grass or already mowed area, change cutting height if necessary
	The mower housing is clogged	Clean housing so blade can move freely
	Battery has no power	Check and recharge battery
Mower stops working/loses power	Cutting height is incorrect	Adjust cutting height
	Cutting blade is worn or damaged	Replace with new blade from dealer service centre
	Battery performance decreasing	Check battery performance and charge if necessary
Grass bag is not filled sufficiently	Cutting height is too low	Adjust and increase cutting height
	The lawn/grass is wet	Allow lawn to dry
	Underside of mower deck is clogged	Clean underside of mower deck
	Cutting blade is worn or damaged	Replace by contacting customer service centre
Mower vibrating at higher speed	Cutting blade is unbalanced	Balance blade by grinding each cutting edge until equal
	Blade is loose/incorrectly fitted	Tighten blade bolt
Mower cuts unevenly	The blade is damaged	Sharpen blade or replace
	Blade is assembled incorrectly	Re-assemble blade correctly

Technical Data

Property	Value
Model no.	YOJ33440-ZB
Nominal voltage of product with battery	40V(2X20V)  / 2.5Ah
No-load cutting speed	3800min ⁻¹
Cutting width	34cm
Cutting height	20-70mm, 6 positions
Capacity of grass bag	35l
Weight	13.1kg
Measured sound pressure level(L _{PA})	79.3dB(A), K=3dB(A)
Measured sound power level(L _{WA})	90.22dB(A), K=0.62dB(A)
Guaranteed sound power level	96dB(A)
Vibrations	3.89m/s ² K=1.5m/s ²
Battery pack model	BOP-SPO7-20-ZR
Battery capacity	20V  2.5Ah
Battery charging time	120min
USB-A	5V  2A
Battery charger model	BOQ-SPO7-2040ZB
Input	220-240V~, 50/60Hz 120W
Output	21V  4A
Protection class	 / II

The sound values have been determined according to noise test code given in EN IEC 62841-4-3, using the basic standards EN ISO 11201 and EN ISO 3744.

The sound intensity level for the operator may exceed 80dB(A) and ear protection measures are necessary.

The declared vibration value has been measured in accordance with a standard test method (according to EN IEC 62841-4-3) and may be used for comparing one product with another. The declared vibration value may also be used in a preliminary assessment of exposure.



WARNING: Depending on the actual use of the product, the vibration values can differ from the declared total! Adopt proper measures to protect yourself against vibration exposure! Take into consideration the whole work process, including times the product is running under no load or is switched off.

HAVS



WARNING! This equipment may cause Hand-Arm Vibration Syndrome (HAVS) if its use is not adequately monitored and managed.

Preventative measures include, among others, regular maintenance and care of the product and cutting attachments, keeping hands warm and periodical breaks, as well as proper planning of work processes.

Disposal

The lawn mower and its accessories are made of various recyclable materials. Dispose of the lawn mower in accordance with your local recycling regulations.

Getting Help

Our dedicated UK-based customer helpline is open 7 days a week to assist you with assembly, parts queries and technical support. We are open during office hours but you can always send an email via **support@coreservice.co.uk**. Our experts are here to get you back enjoying your garden in no time.

For useful assembly, starting and maintenance videos, and for ordering spares, please visit **www.coreservice.co.uk**.

Calling our helpline does not affect your statutory rights.

Warranty

This product is covered by a 3 year warranty.

The warranty covers any manufacturing defect in materials, workmanship and finish.

Any claim under this warranty must be made by going to your nearest Homebase store, taking your proof of purchase with you, and claims must be made within 3 years of the date of purchase.

We will offer you a free repair of the item where this is possible, or a replacement or a refund. Your statutory rights remain unaffected, in particular, any rights you may have under the Consumer Rights Act 2015.

This warranty is given by HHGL Limited, MK9 1BA; HHGL (ROI) Limited, D02 X576.

Please note: This warranty does not apply to products misused or neglected and only covers domestic use. It does not apply to commercial use of the product. The warranty period for battery pack and charger is 1 year.