

# SOVEREIGN

## 135W ROTARY TOOL SET

Item No. 594448

Model No. DM-130B-1



Technical Support & Parts  
**01904 727509**  
Mon-Fri 9am-5pm Sat-Sun 11am-4pm  
[www.coreservice.co.uk](http://www.coreservice.co.uk)

## ORIGINAL INSTRUCTION MANUAL

Please read these instructions fully before starting assembly.

HHGL Limited, MK9 1BA; HHGL (ROI) Limited, D02 X576

Mar 21

# CONTENTS

Contents	2
General safety warnings	3
Warning symbols	16
In the box	17
Operation	18
Maintenance and storage	24
Technical data	25
Recycling and disposal	27
UK plug	27
Getting help	28
Warranty	28

# GENERAL SAFETY INFORMATION



**WARNING! Read all safety warnings, instructions, illustrations and specifications provided with this power tool.**

Failure to follow all instructions listed below may result in electric shock, fire and/or serious injury.

**Save all warnings and instructions for future reference.**

The term "power tool" in the warnings refers to your mains-operated (corded) power tool or battery-operated (cordless) power tool.

## 1) Work area safety

- a. **Keep work area clean and well lit.** Cluttered or dark areas invite accidents.
- b. **Do not operate power tools in explosive atmospheres, such as in the presence of flammable liquids, gases or dust.** Power tools create sparks which may ignite the dust or fumes.
- c. **Keep children and bystanders away while operating a power tool.** Distractions can cause you to lose control.

## 2) Electrical safety

- a. **Power tool plugs must match the outlet. Never modify the plug in any way. Do not use any adaptor plugs with earthed (grounded) power**

**tools.** Unmodified plugs and matching outlets will reduce risk of electric shock.

- b. Avoid body contact with earthed or grounded surfaces, such as pipes, radiators, ranges and refrigerators.** There is an increased risk of electric shock if your body is earthed or grounded.
- c. Do not expose power tools to rain or wet conditions.** Water entering a power tool will increase the risk of electric shock.
- d. Do not abuse the cord. Never use the cord for carrying, pulling or unplugging the power tool. Keep cord away from heat, oil, sharp edges or moving parts.** Damaged or entangled cords increase the risk of electric shock.
- e. When operating a power tool outdoors, use an extension cord suitable for outdoor use.** Use of a cord suitable for outdoor use reduces the risk of electric shock.
- f. If operating a power tool in a damp location is unavoidable, use a residual current device (RCD) protected supply.** Use of an RCD reduces the risk of electric shock.

### **3) Personal safety**

- a. Stay alert, watch what you are doing and use common sense when operating a power tool. Do not use a power tool while you are tired or under the influence of drugs, alcohol**

**or medication.** A moment of inattention while operating power tools may result in serious personal injury.

- b. Use personal protective equipment. Always wear eye protection.** Protective equipment such as dust mask, non-skid safety shoes, hard hat, or hearing protection used for appropriate conditions will reduce personal injuries.
- c. Prevent unintentional starting. Ensure the switch is in the 'off' position before connecting to power source and/or battery pack, picking up or carrying the tool.** Carrying power tools with your finger on the switch or energising power tools that have the switch on invites accidents.
- d. Remove any adjusting key or wrench before turning the power tool on.** A wrench or a key left attached to a rotating part of the power tool may result in personal injury.
- e. Do not overreach. Keep proper footing and balance at all times.** This enables better control of the power tool in unexpected situations.
- f. Dress properly. Do not wear loose clothing or jewellery. Keep your hair, clothing and gloves away from moving parts.** Loose clothes, jewellery or long hair can be caught in moving parts.
- g. If devices are provided for the connection of dust extraction and collection facilities, ensure these are connected and properly used.** Use of these devices can reduce dust-related hazards.

- h. Do not let familiarity gained from frequent use of tools allow you to become complacent and ignore tool safety principles.** A careless action can cause severe injury within a fraction of a second.

#### **4) Power tool use and care**

- a. Do not force the power tool. Use the correct power tool for your application.** The correct power tool will do the job better and safer at the rate for which it was designed.
- b. Do not use the power tool if the switch does not turn it on and off.** Any power tool that cannot be controlled with the switch is dangerous and must be repaired.
- c. Disconnect the plug from the power source and/or the battery pack from the power tool before making any adjustments, changing accessories, or storing power tools.** Such preventive safety measures reduce the risk of starting the power tool accidentally.
- d. Store idle power tools out of the reach of children and do not allow persons unfamiliar with the power tool or these instructions to operate the power tool.** Power tools are dangerous in the hands of untrained users.
- e. Maintain power tools. Check for misalignment or binding of moving parts, breakage of parts and any other condition that may affect the power tools operation. If damaged, have the**

**power tool repaired before use.** Many accidents are caused by poorly maintained power tools.

- f. Keep cutting tools sharp and clean.** Properly maintained cutting tools with sharp cutting edges are less likely to bind and are easier to control.
- g. Use the power tool, accessories and tool bits, etc., in accordance with these instructions, taking into account the working conditions and the work to be performed.** Use of the power tool for operations different from those intended could result in a hazardous situation.
- h. Keep handles and gripping surfaces dry, clean and free from oil and grease.** Slippery handles and gripping surfaces do not allow for safe handling and control of the tool in unexpected situations.

## Service

**a) Have your power tool serviced by a qualified repair person using only identical replacement parts.** This will ensure that the safety of the power tool is maintained.

## SAFETY INSTRUCTIONS FOR ALL OPERATIONS

**Safety Warnings common for grinding, sanding, wire brushing, polishing, carving or abrasive cutting-off operations:**

**a) This power tool is intended to function as a grinder, sander, wire brush, polisher, carver or cut-off tool. Read all safety warnings, instructions, illustrations and specifications provided with this power tool.** Failure to follow all instructions listed below may result in electric shock, fire and/or serious injury.

**b) Operations such as polishing is not recommended to be performed with this power tool.** Operations for which the power tool was not designed may create a hazard and cause personal injury.

**c) Do not use accessories which are not specifically designed and recommended by the tool manufacturer.** Just because the accessory can be attached to your power tool, it does not assure safe operation.

**d) The rated speed of the grinding accessories must be at least equal to the maximum speed marked on the power tool.** Grinding accessories running faster than their rated speed can break and fly apart.

**e) The outside diameter and the thickness of your accessory must be within the capacity rating of your power tool.** Incorrectly sized accessories cannot be adequately controlled.

**f) The arbour size of wheels, sanding drums or any other accessory must properly fit the spindle or collet of the power tool.** Accessories that do not match the mounting hardware of the power tool will run out of balance, vibrate excessively and may cause loss of control.

**g) Mandrel mounted wheels, sanding drums, cutters or other accessories must be fully inserted into the collet or chuck.** If the mandrel is insufficiently held and/or the overhang of the wheel is too long, the mounted wheel may become loose and be ejected at high velocity.

**h) Do not use a damaged accessory. Before each use, inspect the accessory, such as abrasive wheels for chips and cracks, sanding drum for cracks, tear or excess wear, wire brush for loose or cracked wires. If the power tool or accessory is dropped, inspect for damage or install an undamaged accessory. After inspecting and installing an accessory, position yourself and bystanders away from the plane of the rotating accessory and run the power tool at maximum no-load speed for one minute.** Damaged accessories will normally break apart during this test time.

**i) Wear personal protective equipment. Depending on application, use a face shield, safety goggles or safety glasses. As appropriate, wear a dust mask, hearing protectors, gloves and workshop apron capable of stopping small abrasive or workpiece fragments.** The eye protection must be capable of stopping flying debris

generated by various operations. The dust mask or respirator must be capable of filtering particles generated by your operation. Prolonged exposure to high intensity noise may cause hearing loss.

**j) Keep bystanders a safe distance away from the work area. Anyone entering the work area must wear personal protective equipment.** Fragments of workpiece or of a broken accessory may fly out and cause injury beyond immediate area of operation.

**k) Hold the power tool by insulated gripping surfaces only, when performing an operation where the cutting accessory may contact hidden wiring or its own cord.** Cutting accessory contacting a “live” wire may make exposed metal parts of the power tool “live” and could give the operator an electric shock.

**l) Always hold the tool firmly in your hand(s) during the start up.** The reaction torque of the motor, as it accelerates to full speed, can cause the tool to twist.

**m) Use clamps to support the workpiece whenever practical. Never hold a small workpiece in one hand and the tool in the other hand while in use.** Clamping a small workpiece allows you to use your hand(s) to control the tool. Round material, such as dowel rods, pipes or tubing, have a tendency to roll while being cut, and may cause the bit to bind or jump toward you.

**n) Position the cord clear of the spinning accessory.** If you lose control, the cord may be cut or snagged and your hand or arm may be pulled into the spinning accessory.

**o) Never lay the power tool down until the accessory has come to a complete stop.** The spinning accessory may grab the surface and pull the power tool out of your control.

**p) After changing the bits or making any adjustments, make sure the collet nut, chuck or any other adjustment devices are securely tightened.** Loose adjustment devices can unexpectedly shift, causing loss of control; loose rotating components will be violently thrown.

**q) Do not run the power tool while carrying it at your side.** Accidental contact with the spinning accessory could snag your clothing, pulling the accessory into your body.

**r) Regularly clean the power tools air vents.** The motors fan will draw the dust inside the housing and excessive accumulation of powdered metal may cause electrical hazards.

**s) Do not operate the power tool near flammable materials.** Sparks could ignite these materials.

**t) Do not use accessories that require liquid coolants.** Using water or other liquid coolants may result in electrocution or shock.

## **Further safety instructions for all operations**

### **Kickback and related warnings**

Kickback is a sudden reaction to a pinched or snagged rotating wheel, sanding band, brush or any other accessory. Pinching or snagging causes rapid stalling of the rotating accessory which in turn causes the uncontrolled power tool to be forced in the direction opposite of the accessory's rotation.

For example, if an abrasive wheel is snagged or pinched by the workpiece, the edge of the wheel that is entering into the pinch point can dig into the surface of the material, causing the wheel to climb out or kick out. The wheel may either jump toward or away from the operator, depending on the direction of the wheels movement at the point of pinching. Abrasive wheels may also break under these conditions.

Kickback is the result of power tool misuse and/or incorrect operating procedures or conditions and can be avoided by taking proper precautions as given below.

**a) Maintain a firm grip on the power tool and position your body and arm to allow you to resist kickback forces.** The operator can control kickback forces, if proper precautions are taken.

**b) Use special care when working corners, sharp edges, etc. Avoid bouncing and snagging the accessory.** Corners, sharp edges or bouncing have a tendency to snag the rotating accessory and cause loss of control or kickback.

**c) Do not attach a toothed saw blade.** Such blades create frequent kickback and loss of control.

**d) Always feed the bit into the material in the same direction as the cutting edge is exiting from the material (which is the same direction as the chips are thrown).** Feeding the tool in the wrong direction causes the cutting edge of the bit to climb out of the work and pull the tool in the direction of this feed.

**e) When using rotary files, cut-off wheels, high-speed cutters or tungsten carbide cutters, always have the work securely clamped.** These wheels will grab if they become slightly canted in the groove, and can kick back. When a cut-off wheel grabs, the wheel itself usually breaks. When a rotary file, high-speed cutter or tungsten carbide cutter grabs, it may jump from the groove and you could lose control of the tool.

### **Safety Warnings Specific for Grinding and Abrasive Cutting-Off Operations:**

**a) Use only wheel types that are recommended for your power tool and only for recommended applications. For example: do not grind with the side of a cut-off wheel.** Abrasive cut-off wheels are intended for peripheral grinding, side forces applied to these wheels may cause them to shatter.

**b) For threaded abrasive cones and plugs, use only undamaged wheel mandrels with an**

**unrelieved shoulder flange that are of correct size and length.** Proper mandrels will reduce the possibility of breakage.

**c) Do not “jam” a cut-off wheel or apply excessive pressure. Do not attempt to make an excessive depth of cut.** Overstressing the wheel increases the loading and susceptibility to twisting or snagging of the wheel in the cut and the possibility of kickback or wheel breakage.

**d) Do not position your hand in line with or behind the rotating wheel.** When the wheel, at the point of operation, is moving away from your hand, the possible kickback may propel the spinning wheel and the power tool directly at you.

**e) When the wheel is pinched, snagged or when interrupting a cut for any reason, switch off the power tool and hold the power tool motionless until the wheel comes to a complete stop. Never attempt to remove the cut-off wheel from the cut while the wheel is in motion, otherwise kickback may occur.** Investigate and take corrective action to eliminate the cause of wheel pinching or snagging.

**f) Do not restart the cutting operation in the workpiece. Let the wheel reach full speed and carefully re-enter the cut.** The wheel may bind, walk up or kickback if the power tool is restarted in the workpiece.

**g) Support panels or any oversized workpiece to minimise the risk of wheel pinching and kickback.** Large workpieces tend to sag under their own weight. Supports must be placed under the workpiece near

the line of cut and near the edge of the workpiece on both sides of the wheel.

**h) Use extra caution when making a “pocket cut” into existing walls or other blind areas.**

The protruding wheel may cut gas or water pipes, electrical wiring or objects that can cause kickback.

### **Safety Warnings Specific for Wire Brushing Operations:**

**a) Be aware that wire bristles are thrown by the brush even during ordinary operation. Do not overstress the wires by applying excessive load to the brush.** The wire bristles can easily penetrate light clothing and/or skin.

**b) Allow brushes to run at operating speed for at least one minute before using them. During this time, no one is to stand in front or in line with the brush.** Loose bristles or wires will be discharged during the run-in time.

**c) Direct the discharge of the spinning wire brush away from you.** Small particles and tiny wire fragments may be discharged at high velocity during the use of these brushes and may become imbedded in your skin.

# WARNING SYMBOLS



Warning!



Read the instructions



Wear ear protection



Wear eye protection



Wear a dust mask



Class II tool



The product complies with the applicable European directives, and an evaluation method of conformity for these directives was done.



Recycle unwanted materials instead of disposing of them as household waste. All tools, hoses and packaging should be sorted, taken to the local recycling centre and disposed of in an environmentally safe way.



The product complies with the applicable UK directives, and an evaluation method of conformity for these directives was followed.

# IN THE BOX

## Description

- |   |                   |
|---|-------------------|
| 1. Collet nut                             | 5. Hook           |
| 2. Spindle lock button                    | 6. On/Off switch  |
| 3. Carbon brush holder<br>(on both sides) | 7. Spanner        |
| 4. Speed selector                         | 8. Flexible shaft |

## Accessories

- |                                 |                    |
|---------------------------------|--------------------|
| 10pcs Grinding wheel with shank | 1pc Spanner        |
| 2pcs Diamond bits               | 1pc Whet stone     |
| 4pcs Sanding drum               | 1pc Flexible shaft |
| 1pc Sanding shank               |                    |
| 2pcs Drill bits                 |                    |
| 2pcs Mandrel                    |                    |
| 4pcs Felt wheel                 |                    |
| 8pcs Cutting disk               |                    |
| 3pcs Sanding paper              |                    |
| 2pcs Collets (3.2mm & 2.3mm)    |                    |

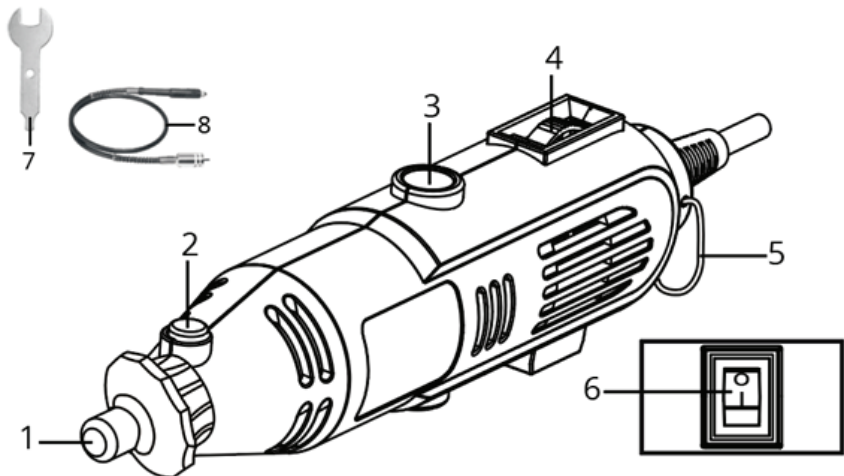

# OPERATION



**NOTE:** Before using the tool, read the instruction book carefully.

## Intended Use

This tool is intended for grinding and polishing metal, as well as for cutting metal and drilling into metal and wood.

### 1. CHANGE THE COLLET (SEE FIG. A)

Two sizes (3.2mm pre-assembled, 2.3mm as an accessory) of collets are provided to accommodate the different accessories shank sizes.

When using an accessory with a smaller or larger shaft, you will need to change the collet which matches the shank size of the accessory, as follows:

Press the spindle lock button. Loosen the collet nut (1) with the spanner provided. Remove the collet nut (1) and then fully insert the appropriate size collet into the spindle.

Reinstall the collet nut (1) finger tight. Do not over-tighten the nut when there is no accessory in the collet.



**WARNING!** Fully tighten the collet nut before operation. Always use the collet which matches the shank size of the accessory you plan to use. Do not force a larger diameter shank into a smaller collet.

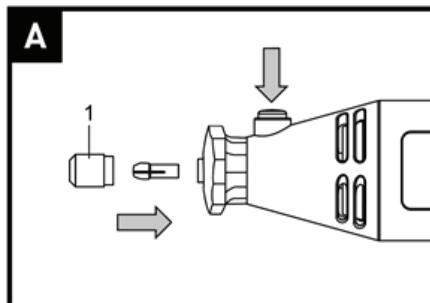

## 2. FITTING AN ACCESSORY (SEE FIG. B, C)

Press the spindle lock button. Hold down and rotate the spindle by hand until the spindle lock engages with the spindle. Loosen the collet nut anti-clockwise using the spanner if necessary.

Fully insert the tool shank into the collet. Tighten the collet nut with the spanner but do not over-tighten. Finally release the spindle lock button.



**WARNING!** Do not engage the spindle lock button while the tool is running.

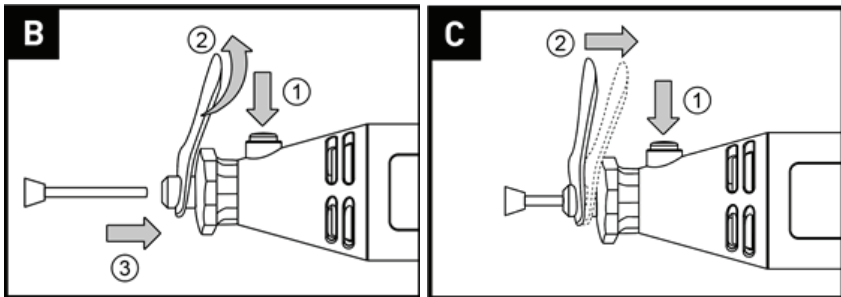

## 3. FITTING A CUTTING/SANDING WHEEL (SEE FIG. D, E)

First, fit the cutting wheel fixture into the collet. Loosen the small screw (a) on the cutting wheel fixture with the top of the collet spanner. Insert the screw through the cutting wheel and then screw into the cutting wheel fixture. Do not over-tighten, otherwise the wheel may crack.

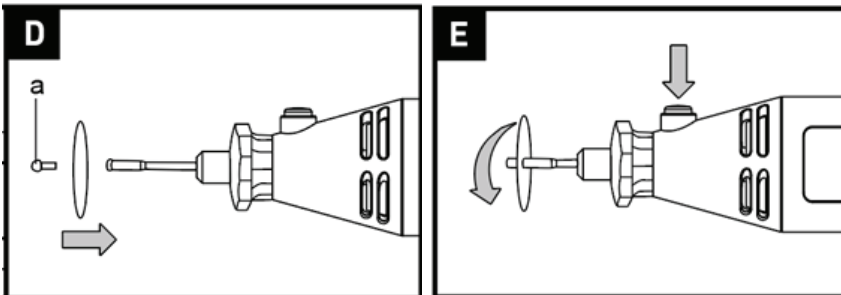

#### 4. ASSEMBLING THE FELT WHEEL (SEE FIG. F)

The felt wheel is used with the mandrel. Thread the wheel on to the screw carefully.

The felt wheel must thread down straight on the mandrel, and be turned all the way to the collar.

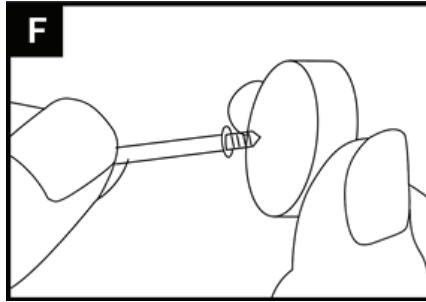

#### 5. FITTING THE SANDING ROLL (SEE FIG. G1, G2, G3)

To fit the sanding roll, firstly loosen the small screw on top of the hole for the rubber wheel, this will allow the rubber to relax. Slide the sanding roll onto the holder.

To secure, simply tighten the screw and the rubber roll will swell, gripping the sanding drum.

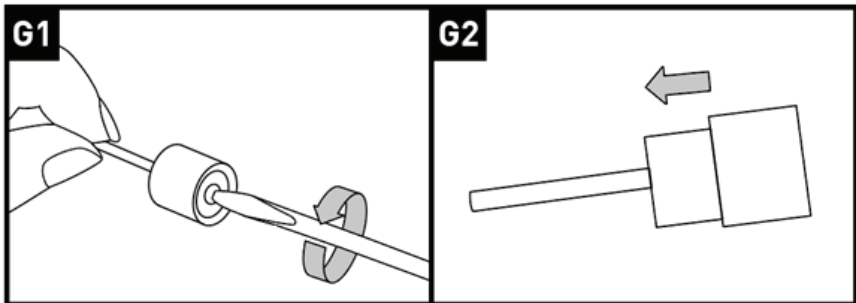

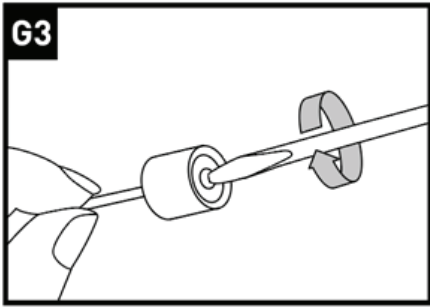

## 6. CONNECT THE FLEXIBLE SHAFT TO THE TOOL (SEE FIG. H)



**WARNING!** Never bend the flexible shaft with a radius of less than 152mm when operating. Always store the flexible shaft carefully to avoid sharp bends when not in use.

- 1) Depress the spindle lock button (2) and unscrew counter-clockwise the collet nut (1) and plastic ring (a) from the spindle.
- 2) Remove the collet ring(a).
- 3) Insert the inner shaft (c) of the flexible shaft into the collet nut (1) and right collect, then put the collect into the spindle socket (b) until the bump (d) touches the collet nut (1).
- 4) Press the spindle lock button (2), tighten the collet nut (1) with the spanner but do not over-tighten.
- 5) Screw clockwise the fixed ring (e) of the flexible shaft onto the housing thread. Tighten the fixed ring (e) by hand.

## 7. REPLACE THE COLLET & ACCESSORIES ONTO FLEXIBLE SHAFT (SEE FIG. I)

- 1) Rotate the collet of the flexible shaft until the hole on the shaft is aligned with the hole (f) of the flexible shaft collar; insert the locking pin to lock the inner shaft (c), and then unscrew counter-clockwise the collet nut with the spanner (7) supplied.

2) Fit the accessory to the spindle socket of the flexible shaft through the appropriate size collet. Keep the locking pin to lock the inner shaft (c), and tighten the collet nut clockwise using the spanner.



**WARNING!** Fully tighten the collet nut before operation. Always use the collet which matches the shank size of the accessory you plan to use. Do not force a small diameter shank into a large collet.



**WARNING!** Do not attempt to loosen or tighten the collet without locking the shaft, as noted above. Damage to the flexible shaft will result.

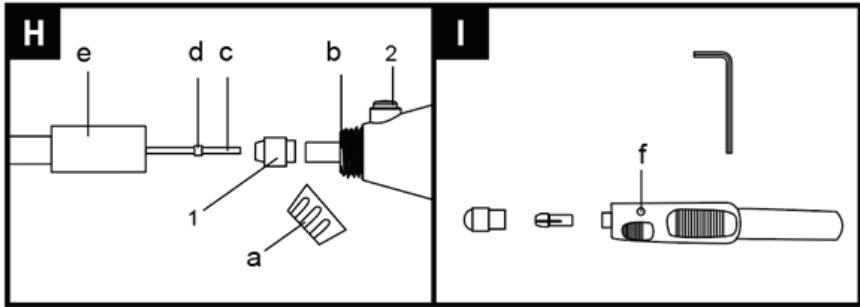

## OPERATION

### 1. SWITCH ON/OFF (SEE FIG. J)

**NOTE:** This tool has been set to the slowest speed before switching on.

To start the tool, press the on/off switch to “I” ON position. To stop, press the switch to “O” OFF position.

### 2. SPEED ADJUSTMENT (SEE FIG. K)

To achieve the best result when working with different materials, you can adjust the tool speed. It is adjustable from 10000 to 32000/min.

The tool has a variable speed control for precise speed adjustment. Set it to the required speed for operation.

**NOTE:** Select a low speed when working with wood, plastics and polishing.

Generally, select a higher speed for small tools while lower speed for larger tools.

From number "1" to "MAX.", the speed is corresponding from 10000 to 32000/min.

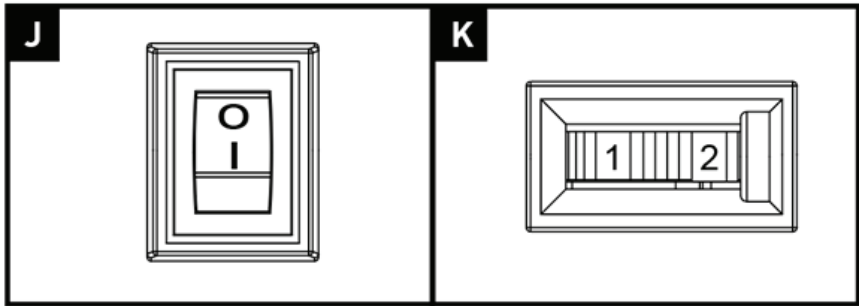

### 3. DRILLING OPERATION

Turn the tool on until it reaches full speed. Gently apply the tool to the workpiece. To obtain a good finish, slowly move the tool in the leftward direction.

**NOTE:** Apply light pressure with the tool. Excessive pressure will only cause a poor finish and overloading of the motor.

### 4. HOLDING THE TOOL

For milling or engraving, hold the tool like a pen. Take care not to cover the ventilation slots.

**NOTE:** The tool will get warm during normal operation. Observe the rated operating time.

### 5. USING THE DRILLS

The HSS twist drills are used to cut through all types of steels and steel composites.

## 6. POLISHING WITH THE FELT WHEEL

After assembling the felt wheel to the screw drill (SEE FIG. F), it can be used to polish plastics, metals, steels, jewellery and small parts with a polishing compound, which will give a high lustre to the surfaces of the materials. For best results, polishing accessories should be used at speeds not greater than half speed.

## MAINTENANCE AND STORAGE



### IMPORTANT:

Make sure that the tool has been thoroughly cleaned before storing it in a clean, dry and safe place, out of the reach of children.

1. Switch the product 'OFF' and disconnect it from the power supply before transporting it anywhere.
2. Always carry the product on its gripping surfaces.
3. Protect the product from any heavy impact or strong vibrations which may occur during transportation in vehicles.
4. Secure the product to prevent it from slipping or falling over.

# TECHNICAL DATA

<b>Model</b>	<b>DM-130B-1</b>
Voltage/power	220V-240V~ 50Hz /135W
No-load speed	10000-32000/min
Collet size	3.2mm & 2.3mm
Capacity	Φ35mm (max. grinding disc) Φ3.2mm (drilling bit)
Protection class	II / 
Weight	1.4kg
Spindle thread size	M8*0.75mm
<b>Noise and vibration data</b>	
A weighted sound pressure ( $L_{pA}$ )	72 dB(A), k=3dB(A)
A weighted sound power ( $L_{wA}$ )	83 dB(A), k=3dB(A)
Vibrations	$a_h=1.42m/s^2$ , $K=1.5m/s^2$

The sound intensity level for the operator may exceed 80 dB(A) and ear protection measures are necessary.

The declared vibration value has been measured in accordance with a standard test method (according to EN 60745) and may be used for comparing one product with another. The declared vibration value may also be used in a preliminary assessment of exposure.



## WARNING!

The vibration emission value during actual use of the power tool can differ from the declared value depending on the ways in which the tool is used and dependant on the following examples and other variations on how the tool is used: How the tool is used and the materials being cut or drilled.

The tool being in good condition and well maintained.  
The use the correct accessory for the tool and ensuring it is sharp and in good condition.

The tightness of the grip on the handles and if any anti-vibration accessories are used.

And the tool is being used as intended by its design and these instructions.

**This tool may cause hand-arm vibration syndrome if its use is not adequately managed.**



**WARNING!** To be accurate, an estimation of exposure level in the actual conditions of use should also take account of all parts of the operating cycle, such as the times when the tool is switched off and when it is running idle but not actually doing the job. This may significantly reduce the exposure level over the total working period.

Helping to minimise your vibration exposure risk.

ALWAYS use sharp chisels, drills and blades.

Maintain this tool in accordance with these instructions and keep well lubricated (where appropriate).

If the tool is to be used regularly then invest in anti-vibration accessories.

Plan your work schedule to spread any high vibration tool use across a number of days.

# RECYCLING AND DISPOSAL



Waste electrical products should not be disposed with household waste. Please recycle where facilities exist. Check with your local authority or retailer for recycling advice.

# UK PLUG

If you need to replace the fitted plug then follow the instructions below.

**IMPORTANT:** The wires in the mains lead are coloured in accordance with the following code: Blue–Neutral, Brown–Live



**WARNING!** Never connect live or neutral wires to the earth terminal of the plug. Only fit an approved 3Amp BS1363/A plug and the correct rated fuse.

As the colours of the wire in the mains lead of this product may not correspond with the coloured markings identifying the terminals in your plug, proceed as follows: The blue wire must be connected to the terminal marked N or coloured black. The brown wire must be connected to the terminal marked L or coloured red.

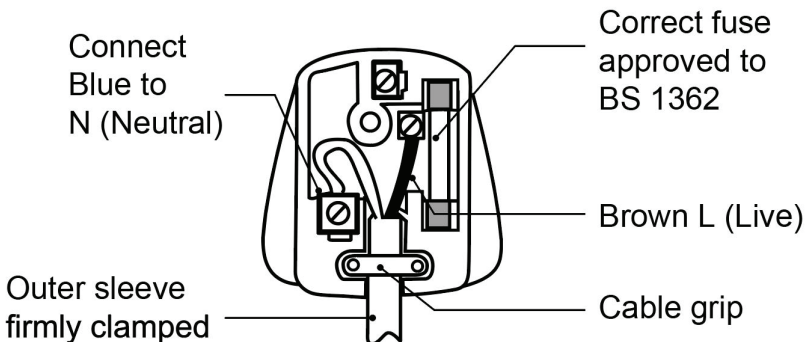

## GETTING HELP

Our dedicated UK-based customer helpline is open 7 days a week to assist you with assembly, parts queries and technical support. We are open during office hours but you can always send an email via **support@coreservice.co.uk**. Our experts are here to get you back enjoying your garden in no time.

For useful assembly, starting and maintenance videos, and ordering spares, please visit **www.coreservice.co.uk**.

Calling our service does not affect your statutory rights.

## WARRANTY

This product is covered by a 1 year warranty.

The warranty covers any manufacturing defect in materials, workmanship and finish.

Any claim under this warranty must be made by going to your nearest Homebase store, taking your proof of purchase with you, and claims must be made within 12 months of the date of purchase.

We will offer you a free repair of the item where this is possible, or a replacement or a refund. Your statutory rights remain unaffected, in particular any rights you may have under the Consumer Rights Act 2015.

This warranty is given by HHGL Limited, MK9 1BA; HHGL (ROI) Limited, D02 X576.

Please note: This warranty does not apply to products misused or neglected and only covers domestic use. It does not apply to commercial use of the product. In addition, the warranty will be void for the following reasons: Any damage resulting from product misuse or product neglect.