

SOVEREIGN

10.8V DRILL DRIVER

Item No. 594456

Model No. D023-10.8V



Technical Support & Parts
01904 727509
Mon-Fri 9am-5pm Sat-Sun 11am-4pm
www.coreservice.co.uk

ORIGINAL INSTRUCTION MANUAL

Please read these instructions fully before starting assembly.

HHGL Limited, MK9 1BA; HHGL (ROI) Limited, D02 X576

Mar 21

CONTENTS

CONTENTS	2
GENERAL SAFETY WARNINGS	3
WARNING SYMBOLS	14
IN THE BOX	16
OPERATION	20
MAINTENANCE AND STORAGE	25
TECHNICAL DATA	26
RECYCLING AND DISPOSAL	28
GETTING HELP	28
WARRANTY	29

GENERAL SAFETY WARNINGS



WARNING! Read all safety warnings, instructions, illustrations and specifications provided with this power tool. Failure to follow all instructions listed below may result in electric shock, fire and/or serious injury.

Save all warnings and instructions for future reference. The term "power tool" in the warnings refers to your mains-operated (corded) power tool or battery-operated (cordless) power tool.

1) Work area safety

- a) **Keep work area clean and well lit.** Cluttered or dark areas invite accidents.
- b) **Do not operate power tools in explosive atmospheres, such as in the presence of flammable liquids, gases or dust.** Power tools create sparks which may ignite the dust or fumes.
- c) **Keep children and bystanders away while operating a power tool.** Distractions can cause you to lose control.

2) Electrical safety

- a) **Power tool plugs must match the outlet. Never modify the plug in any way.** Do not use any adaptor plugs with earthed (grounded) power tools. Unmodified plugs and matching outlets will reduce risk of electric shock.
- b) **Avoid body contact with earthed or grounded surfaces, such as pipes, radiators, ranges and**

refrigerators. There is an increased risk of electric shock if your body is earthed or grounded.

- c) **Do not expose power tools to rain or wet conditions.** Water entering a power tool will increase the risk of electric shock.
- d) **Do not abuse the cord. Never use the cord for carrying, pulling or unplugging the power tool.** Keep cord away from heat, oil, sharp edges or moving parts. Damaged or entangled cords increase the risk of electric shock.
- e) **When operating a power tool outdoors, use an extension cord suitable for outdoor use.** Use of a cord suitable for outdoor use reduces the risk of electric shock.
- f) **If operating a power tool in a damp location is unavoidable, use a residual current device (RCD) protected supply.** Use of an RCD reduces the risk of electric shock.

3) Personal safety

- a) **Stay alert, watch what you are doing and use common sense when operating a power tool.** Do not use a power tool while you are tired or under the influence of drugs, alcohol or medication. A moment of inattention while operating power tools may result in serious personal injury.
- b) **Use personal protective equipment (PPE). Always wear eye protection.** Protective equipment, such as a dust mask, non-skid safety shoes, hard hat, or hearing protection used for

appropriate conditions will reduce personal injuries.

- c) **Prevent unintentional starting. Ensure the switch is in the 'off' position before connecting to power source and/or battery pack, picking up or carrying the tool.** Carrying power tools with your finger on the switch or energising power tools that have the switch on invites accidents.
- d) **Remove any adjusting key or wrench before turning the power tool on.** A wrench or a key left attached to a rotating part of the power tool may result in personal injury.
- e) **Do not overreach. Keep proper footing and balance at all times.** This enables better control of the power tool in unexpected situations.
- f) **Dress properly. Do not wear loose clothing or jewellery.** Keep your hair, clothing and gloves away from moving parts. Loose clothes, jewellery or long hair can be caught in moving parts.
- g) **If devices are provided for the connection of dust extraction and collection facilities, ensure these are connected and properly used.** Use of these devices can reduce dust-related hazards.
- h) **Do not let familiarity gained from frequent use of tools allow you to become complacent and ignore tool safety principles.** A careless action can cause severe injury within a fraction of a second.

4) Power tool use and care

- a) **Do not force the power tool. Use the correct**

power tool for your application. The correct power tool will do the job better and safer at the rate for which it was designed.

- b) Do not use the power tool if the switch does not turn it on and off.** Any power tool that cannot be controlled with the switch is dangerous and must be repaired.
- c) Disconnect the plug from the power source and/or the battery pack from the power tool before making any adjustments, changing accessories, or storing power tools.** Such preventive safety measures reduce the risk of starting the power tool accidentally.
- d) Store idle power tools out of the reach of children and do not allow persons unfamiliar with the power tool or these instructions to operate the power tool.** Power tools are dangerous in the hands of untrained users.
- e) Maintain power tools. Check for misalignment or binding of moving parts, breakage of parts and any other condition that may affect the power tool's operation.** If damaged, have the power tool repaired before use. Many accidents are caused by poorly maintained power tools.
- f) Keep cutting tools sharp and clean.** Properly maintained cutting tools with sharp cutting edges are less likely to bind and are easier to control.
- g) Use the power tool, accessories and tool bits etc. in accordance with these instructions, taking into account the working conditions and**

the work to be performed. Use of the power tool for operations different from those intended could result in a hazardous situation.

h) Keep handles and gripping surfaces dry, clean and free from oil and grease. Slippery handles and gripping surfaces do not allow for safe handling and control of the tool in unexpected situations.

5) Battery tool use and care

a) Recharge only with the charger specified by the manufacturer. A charger that is suitable for one type of battery pack may create a risk of fire when used with another battery pack.

b) Use power tools only with specifically designated battery packs. Use of any other battery packs may create a risk of injury and fire.

c) When battery pack is not in use, keep it away from other metal objects, like paper clips, coins, keys, nails, screws or other small metal objects, that can make a connection from one terminal to another. Shorting the battery terminals together may cause burns or a fire.

d) Under abusive conditions, liquid may be ejected from the battery; avoid contact. If contact accidentally occurs, flush with water. If liquid contacts eyes, additionally seek medical help. Liquid ejected from the battery may cause irritation or burns.

e) Do not use a battery pack or tool that is damaged or modified. Damaged or modified

batteries may exhibit unpredictable behaviour resulting in fire, explosion or risk of injury.

- f) **Do not expose a battery pack or tool to fire or excessive temperature.** Exposure to fire or temperature above 130°C may cause explosion.
- g) **Follow all charging instructions and do not charge the battery pack or tool outside the temperature range specified in the instructions.** Charging improperly or at temperatures outside the specified range may damage the battery and increase the risk of fire.

6) Service

- a) **Have your power tool serviced by a qualified repair person using only identical replacement parts.** This will ensure that the safety of the power tool is maintained.
- b) **Never service damaged battery packs.** Service of battery packs should only be performed by the manufacturer or authorised service providers.

Drill safety warnings

1) Safety instructions for all operations

- a) **Hold the power tool by insulated gripping surfaces, when performing an operation where the cutting accessory may contact hidden wiring or its own cord.** Cutting accessory contacting a “live” wire may make exposed metal parts of the power tool “live” and could give the operator an electric shock.

2) Safety instructions when using long drill bits

- a) **Never operate at higher speed than the maximum speed rating of the drill bit.** At higher speeds, the bit is likely to bend if allowed to rotate freely without contacting the workpiece, resulting in personal injury.
- b) **Always start drilling at low speed and with the bit tip in contact with the workpiece.** At higher speeds, the bit is likely to bend if allowed to rotate freely without contacting the workpiece, resulting in personal injury.
- c) **Apply pressure only in direct line with the bit and do not apply excessive pressure.** Bits can bend causing breakage or loss of control, resulting in personal injury.

Safety notes for battery/charger

Safety Warnings for battery pack

- a) **Do not dismantle, open or shred cells or battery pack.**
- b) **Do not short-circuit a battery pack. Do not store battery packs haphazardly in a box or drawer where they may short-circuit each other or be short circuited by conductive materials.** When battery pack is not in use, keep it away from other metal objects, like paper clips, coins, keys, nails, screws or other small metal objects, that can make a connection from one terminal to another. Shorting the battery terminals together may cause burns or a fire.

- c) **Do not expose battery pack to heat or fire. Avoid storage in direct sunlight.**
- d) **Do not subject the battery pack to mechanical shock.**
- e) **In the event of battery leakage, do not allow the liquid to come into contact with the skin or eyes.** If contact has been made, wash the affected area with copious amounts of water and seek medical advice.
- f) **Seek medical advice immediately if a cell or battery pack has been swallowed.**
- g) **Keep battery pack clean and dry.**
- h) **Wipe the battery pack terminals with a clean dry cloth if they become dirty.**
- i) **Battery pack needs to be charged before use.** Always refer to this instruction and use the correct charging procedure.
- j) **Do not maintain battery pack on charge when not in use.**
- k) **After extended periods of storage, it may be necessary to charge and discharge the battery pack several times to obtain maximum performance.**
- l) **Battery pack gives its best performance when it is operated at normal room temperature (20 °C ± 5 °C).**
- m) **When disposing of battery packs, keep battery packs of different electrochemical systems separate from each other.**
- n) **Recharge only with the charger specified.** Do not use any charger other than that specifically

provided for use with the equipment. A charger that is suitable for one type of battery pack may create a risk of fire when used with another battery pack.

- o) Do not use any battery pack which is not designed for use with the equipment.**
- p) Keep the battery pack out of the reach of children.**
- q) Retain the original product literature for future reference.**
- r) Remove the battery from the equipment when not in use.**
- s) Dispose of properly.**
- t) Do not mix cells of different manufacture, capacity, size or type within a device.**
- u) Do not remove battery pack from its original packaging until required for use.**
- v) Observe the plus (+) and minus (-) marks on the battery and ensure correct use.**

General Safety Warnings for battery charger



WARNING! Read all safety warnings and all instructions. Failure to follow the warnings and instructions may result in electric shock, fire and/or serious injury.

Save all warnings and instructions for future reference.

- This appliance can be used by children aged from 8 years and above and persons with reduced

physical, sensory or mental capabilities or lack of experience and knowledge if they have been given supervision or instruction concerning use of the appliance in a safe way and understand the hazards involved.

- Children shall not play with the appliance. Cleaning and user maintenance shall not be made by children without supervision.

If the supply cord is damaged, it must be replaced by the manufacturer, its service agent or similarly qualified persons in order to avoid a hazard.

Additional safety instructions for your Battery Charger

1. Before charging, read the instructions.
2. For charging a Li-ion battery pack only.
3. Do not charge a leaking battery.
4. Do not use chargers for works other than those for which they are designed.
5. Before charging, ensure your charger is matching the local AC supply.
6. The charging device must be protected from moisture.
7. Do not use the charging device in the open.
8. Do not short out the contacts of the battery or charger.
9. Respect the polarity "+/-" when charging.

10. Do not open the unit and keep out of the reach of children.
11. Do not charge the batteries of other manufacturers or ill-suited models.
12. Ensure that the connection between the battery charger and battery is correctly positioned and is not obstructed by foreign bodies.
13. Keep battery chargers slots are free of foreign objects and protect against dirt and humidity. Store in a dry and frost-free place.
14. When charging batteries, ensure that the battery charger is in a well-ventilated area and away from inflammable materials. Batteries can get hot during charging. Do not overcharge any batteries. Ensure that batteries and chargers are not left unsupervised during charging.
15. Do not recharge non-rechargeable batteries, as they can overheat and break.
16. Longer life and better performance can be obtained if the battery pack is charged when the air temperature is between 18°C and 24°C. Do not charge the battery pack in air temperatures below 0°C, or above 40°C. This is important as it can prevent serious damage to the battery pack.
17. Charge only battery pack/s of the same model provided by SOVEREIGN, and of models recommended by SOVEREIGN.
18. After charging, disconnect the battery charger from the supply mains. Then remove the chassis connection and then the battery connection.

WARNING SYMBOLS



Warning!



Read the instructions



Wear ear protection



Wear eye protection



Wear a dust mask



Class II tool



The product complies with the applicable European directives, and an evaluation method of conformity for these directives was done.



Recycle unwanted materials instead of disposing of them as household waste. All tools, hoses and packaging should be sorted, taken to the local recycling centre and disposed of in an environmentally safe way.



The product complies with the applicable UK directives, and an evaluation method of conformity for these directives was followed.



Batteries contain Li-ion. Do not dispose of waste batteries in domestic waste. Contact your local authority to find out how to dispose of batteries.



Do not subject the battery to strong sunlight over long periods of time. Do not leave on a heater (max. 45°C).



Do not throw into water



Do not throw on fire



Pole orientation

IN THE BOX

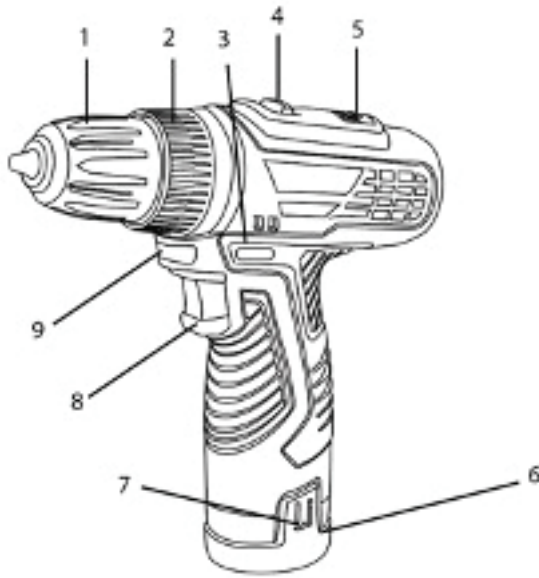

Description

- 1. Keyless chuck
- 2. Torque adjustment ring
- 3. Forward/reverse control level
- 4. Gear selection
- 5. Battery capacity indicator
- 6. Battery pack

- 7. Release button
- 8. ON/OFF Switch
- 9. LED light

OPERATION



NOTE: Before using the tool, read the instruction book carefully.

INTENDED USE

This tool is intended for driving in and loosening screws as well as for drilling in wood, metal and plastic.

BEFORE PUTTING INTO OPERATION

1. CHARGING PROCEDURE

NOTE:

- a) Do not use any charger other than that specifically provided for use with the tool.
- b) If the battery pack is very hot, you must remove your battery pack from the charger and allow time for your battery pack to cool down before recharging.
- c) The battery in your new tool is not charged when it leaves the plant. Therefore, it must be fully charged before using the first time.
- d) Please charge the battery to reach full or no less than half charge before storage. If the tool will not be used for long periods of time, charge the battery every 3-6 months.

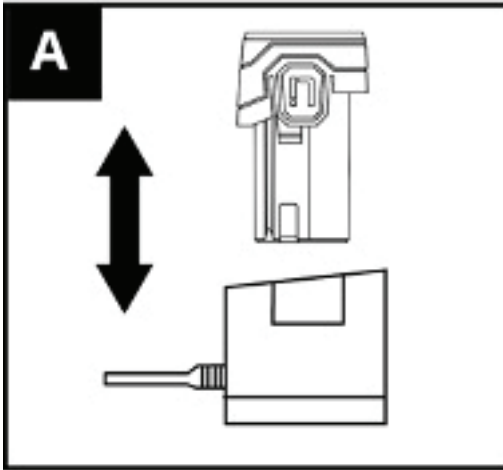

Check the battery capacity via battery capacity indicator (5).

Press the button and check the LEDs:

- Red: battery too low
- Red + yellow: battery half charged
- Red + yellow + green: battery fully charged.

CHARGING

- 1) Plug charger plug into a suitable power outlet, and the charger indicator will be green.
- 2) Insert the battery pack into the charger socket, the charger indicator will be red to indicate the charging process has started.
- 3) On completion of charge, the charger indicator is green. The pack is now fully charged, unplug the charger and remove the battery pack.

IMPORTANT:

When charging, the charger and battery may become warm to the touch, this is normal and does not indicate a problem.



WARNING! When the battery charge runs out after continuous use or exposure to direct sunlight or heat, allow time for the tool to cool down before re-charging to achieve the full charge.

2. INSTALLING AND REMOVING THE BATTERY PACK (SEE FIG. B)

a) TO REMOVE THE BATTERY PACK

First, press the Battery Pack Release Button firmly and then pull the Battery Pack out from your tool.

b) TO INSTALL THE BATTERY PACK

Position the fully charged Battery Pack into the tool with sufficient force until it clicks into position.

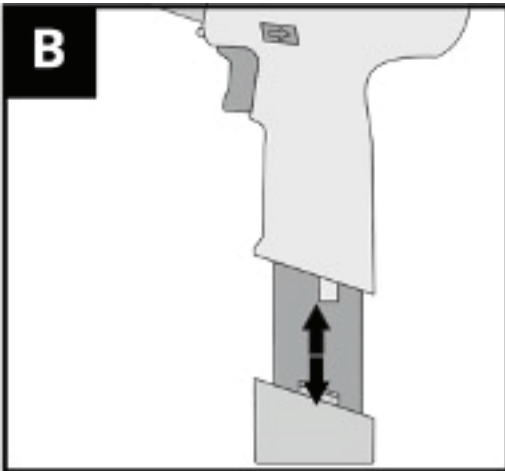

OPERATION

1. ON/OFF SWITCH

Press the On/Off switch (8) to start and release it to stop your drill.

The On/Off switch (8) is fitted with a brake function which stops your chuck immediately when you quickly release the switch.

It is also a variable speed switch that delivers higher speed and torque with increased trigger pressure. Speed is controlled by the amount of switch trigger depression.



WARNING! Do not operate for long periods at low speed because excess heat will be produced internally.

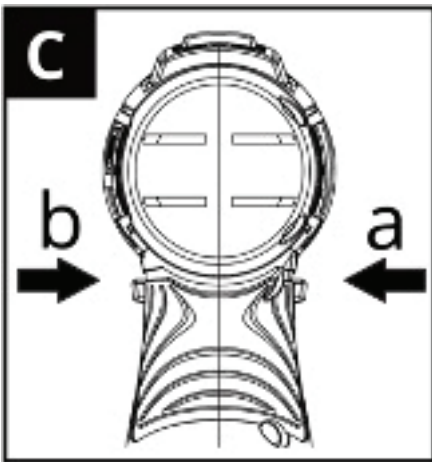

2. SWITCH LOCK

The switch trigger can be locked in the OFF position. This helps to reduce the possibility of accidental starting when not in use. To lock the switch trigger, place the rotation control in the centre position.

3. REVERSIBLE (SEE FIG. C)

For drilling and screw driving use forward rotation marked " ← " (rotation control level (3) is moved to the left). Only use

reverse rotation marked “ ➡ ” (rotation control level (3) is moved to the right) to remove screws or release a jammed drill bit.



WARNING! Never change the direction of rotation when the chuck is rotating, wait until it has stopped!

4. CHUCK ADJUSTMENT (SEE FIG. D)

To open the chuck jaws, rotate the front section of the chuck. Insert the drill bit between the chuck jaws and rotate the front section in the opposite direction. Ensure the drill bit is in the centre of the chuck jaws. Finally, firmly rotate the front chuck section in the opposite direction. Your drill bit is now clamped in the chuck.

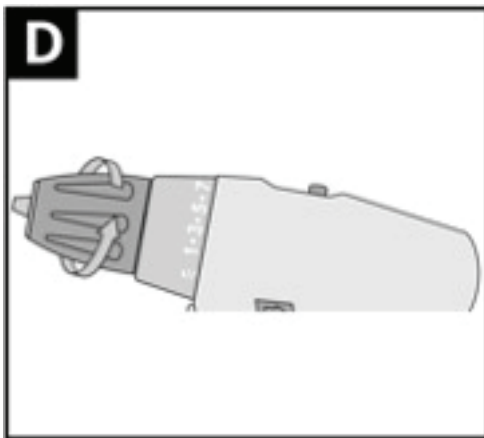

5. TORQUE ADJUSTMENT (SEE FIG. E)

(Screw driving force of your drill driver)

The torque is adjusted by rotating the torque adjustment ring. The torque is greater when the torque adjustment ring is set on a higher setting. The torque is less when the torque adjustment ring is set on a lower setting.

When drilling into wood, metal, plastic and using as a screwdriver, choose the drill position and make the setting as follows:

1 - 4 for driving small screws

5 - 9 for driving screws into soft material

10 - 14 for driving screws into soft and hard material

15 - 20 for driving screws into hard wood

 for heavy drilling.

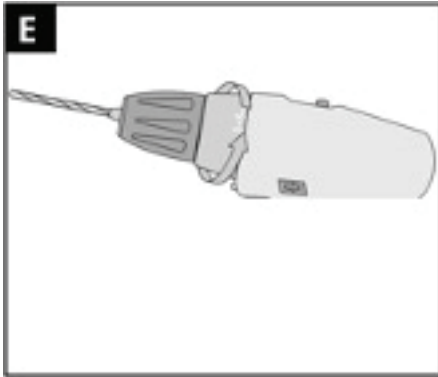

6. USING THE SIGHT LIGHT

To turn on the light, simply press the on/off switch and make sure the forward/reverse rotation control is in the right/left position. When you release the on/off switch, the light will be off.

LED lighting increases visibility; great for dark or enclosed areas.

7. GEAR SELECTION (SEE FIG. F)

For drilling with large drill diameters, choose the slow gear speed I. For drilling with small diameters, choose the fast gear speed II.

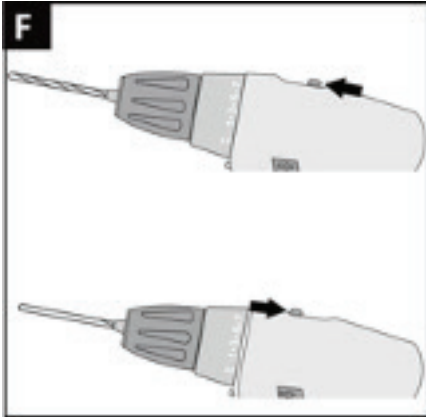

8. DRILLING

When drilling into a hard smooth surface, use a centre punch to mark the desired hole location. This will prevent the drill bit from slipping off centre as the hole is started. Hold the tool firmly and place the tip of the bit at the point to be drilled. Depress the switch trigger to start the tool. Move the drill bit into the workpiece, applying only enough pressure to keep the bit cutting. Do not force or apply side pressure to elongate a hole.

If you want to activate the drill function (for drilling wood or plastic), turn the torque adjustment ring on the drill position.

9. DISPOSAL OF AN EXHAUSTED BATTERY PACK

To preserve natural resources, please recycle or dispose of the battery pack properly.

This battery pack contains Lithium batteries. Consult your local waste authority for information regarding available recycling and/or disposal options. Discharge your battery pack by operating your drill, then remove the battery pack from the drill housing and cover the battery pack connections with heavy-duty adhesive tape to prevent a short circuit and energy discharge. Do not attempt to open or remove any of the components.

10. OVERLOAD PROTECTION

When overloaded, the motor comes to a stop. Relieve the load on the tool immediately and release the On/Off switch. Restart the tool as normal.

11. TEMPERATURE DEPENDENT OVERLOAD PROTECTION

When using as intended, the power tool cannot be subject to overload. When the load is too high or the allowable battery temperature is too hot, the electronic control switches off the power tool until the temperature is in the optimum temperature range again.

12. PROTECTION AGAINST DEEP DISCHARGING

The Lithium battery is protected against deep discharging by the "Discharging Protection System". When the battery is empty, the tool is switched off by means of a protective circuit: The drill will no longer rotate. Remove the battery and recharge.

MAINTENANCE AND STORAGE



IMPORTANT:

Make sure that the tool has been thoroughly cleaned before storing it in a clean, dry and safe place, out of the reach of children.

1. Switch the product 'OFF' and disconnect it from the power supply before transporting it anywhere.
2. Always carry the product on its gripping surfaces.
3. Protect the product from any heavy impact or strong vibrations which may occur during transportation in vehicles.
4. Secure the product to prevent it from slipping or falling over.

TECHNICAL DATA

Model	D023-10.8V
Voltage/power	10.8V/1500mAh Li-ion
No-load speed	0-350/0-1400rpm
Max. torque	25Nm
Torque setting	20+1
Chuck size	10mm
CHARGER	
Model	CL-1350400BS
Input	100-240V~ 50/60Hz 0.4A
Output	13.5V 0.4A
Protection class	□ / II
Weight	1kg
NOISE AND VIBRATION DATA	
A weighted sound pressure (LpA)	59.1 dB(A), k=5dB(A)
A weighted sound power (LwA)	70.1 dB(A), k=5dB(A)
Vibrations	ah=1.097 m/s ² , K=1,5 m/s ²

The sound intensity level for the operator may exceed 80 dB(A) and ear protection measures are necessary.

The declared vibration value has been measured in accordance with a standard test method (according to EN 62841) and may be used for comparing one product with another. The declared vibration value may also be used in a preliminary assessment of exposure.



WARNING!

The vibration emission value during actual use of the power tool can differ from the declared value depending on the ways in which the tool is used and dependant on the following examples and other variations on how the tool is used:

How the tool is used and the materials being cut or drilled.

The tool being in good condition and well maintained.

Using the correct accessory for the tool and ensuring it is sharp and in good condition.

The tightness of the grip on the handles and if any anti-vibration accessories are used.

And the tool is being used as intended by its design and these instructions.

This tool may cause hand-arm vibration syndrome if its use is not adequately managed.



WARNING! To be accurate, an estimation of exposure level in the actual conditions of use should also take account of all parts of the operating cycle, such as the times when the tool is switched off and when it is running idle but not actually doing the job. This may significantly reduce the exposure level over the total working period.

Helping to minimise your vibration exposure risk.

ALWAYS use sharp chisels, drills and blades.

Maintain this tool in accordance with these instructions and keep well lubricated (where appropriate).

If the tool is to be used regularly then invest in anti-vibration accessories.

Plan your work schedule to spread any high vibration tool use across a number of days.

RECYCLING AND DISPOSAL



Waste electrical products should not be disposed with household waste. Please recycle where facilities exist. Check with your local authority or retailer for recycling advice.

GETTING HELP

Our dedicated UK-based customer helpline is open 7 days a week to assist you with assembly, parts queries and technical support. We are open during office hours but you can always send an email via **support@coreservice.co.uk**. Our experts are here to get you back enjoying your garden in no time.

For useful assembly, starting and maintenance videos, and for ordering spares, please visit **www.coreservice.co.uk**.

Calling our service does not affect your statutory rights.

WARRANTY

This product is covered by a 1 year warranty.

The warranty covers any manufacturing defect in materials, workmanship and finish.

Any claim under this warranty must be made by going to your nearest Homebase store, taking your proof of purchase with you, and claims must be made within 12 months of the date of purchase.

We will offer you a free repair of the item where this is possible, or a replacement or a refund. Your statutory rights remain unaffected, in particular any rights you may have under the Consumer Rights Act 2015.

This warranty is given by HHGL Limited, MK9 1BA and HHGL (ROI) Limited, D02 X576.

Please note: This warranty does not apply to products misused or neglected and only covers domestic use. It does not apply to commercial use of the product. In addition, the warranty will be void for the following reasons: Any damage resulting from product misuse or product neglect.