



# SPEAR & JACKSON

ELECTRIC CHAINSAW

**2400W**  
**CS2400**

**ORIGINAL  
INSTRUCTION  
MANUAL**



AFTERSALES SERVICE  
**01904 727505**  
MON-FRI 9am-5pm SAT/SUN 11am-4pm  
[www.spearandjackson-power.com](http://www.spearandjackson-power.com)



**Important** - Please read these instructions fully before operating or maintaining your chainsaw

These instructions contain important information that will help you get the best from your chainsaw, protecting your power tool investment.

# THANK YOU!

Dear Customer,

Thank you for choosing a Spear and Jackson electric chainsaw.

Spear and Jackson was founded in 1760 in the city of Sheffield, which is world famous for the production of steel, cutlery and garden and hand tools.

Through continuous innovation and the use of new technologies and materials, Spear and Jackson has gained an enviable reputation as a supplier of reliable, high performance and high quality products designed to make your work in the garden as easy and enjoyable as possible.

## 3 YEARS GUARANTEE

As a testament to the quality of our products, we offer a free extension of the standard 2 years manufacturer's warranty for all registered products. Simply register your product within 28 days of purchase via [www.spearandjackson-power.com](http://www.spearandjackson-power.com) to extend the standard manufacturer's warranty by an additional 12 months. After registering your product, your garden power tool will be covered for parts and labour for 3 years from the date of purchase, subject to the terms of the warranty. If you do not register your product, it is important to retain your proof of purchase.

## 7 DAYS A WEEK TECHNICAL SUPPORT

We want you to get the best out of your products. Our easy-to-read instruction manual guides you with best practice use and maintenance tips. You can also visit [www.spearandjackson-power.com](http://www.spearandjackson-power.com) for online help, general tips and useful videos about your garden product. However, if you prefer to speak to one of technicians please call **01904 727505, Mon-Fri 9am-5pm and Sat-Sun 11am-4pm**, we can solve around 80% of questions directly over the phone.

We hope you enjoy your product and looking forward to any feedback, as this allows us to develop even better products for the future.

# CONTENTS

<b>Safety Information</b> .....	<b>04</b>
Description of symbols .....	04
General safety .....	05
Personal safety .....	05
Electrical safety .....	06
Operational safety .....	06
Maintenance .....	08
Intended use .....	08
<b>Box Content / Parts</b> .....	<b>09</b>
<b>Preparation</b> .....	<b>10</b>
Tensioning the saw chain .....	10
Chain lubrication .....	11
Check the power supply .....	12
Switching on/off .....	14
Checking the chain brake .....	14
<b>Operation</b> .....	<b>16</b>
Overcutting .....	16
Undercutting .....	17
Cutting logs .....	17
Limbing .....	18
Pruning .....	18
Felling trees .....	19
<b>Maintenance</b> .....	<b>21</b>
General .....	21
Replace the chain .....	21
Chain sharpening .....	22
Cleaning the guide bar and lubricating the sprocket nose .....	23
Check the chain bar .....	23
UK plug .....	24
Storing .....	24
Transport .....	24
Disposal .....	25
<b>Technical Data</b> .....	<b>26</b>
<b>Troubleshooting</b> .....	<b>27</b>
<b>Warranty</b> .....	<b>28</b>
<b>EC DECLARATION OF CONFORMITY</b> .....	<b>29</b>

# SAFETY INFORMATION

Please read these instructions fully before operating or maintaining your machine

## DESCRIPTION OF SYMBOLS

The following warning symbols appear throughout this manual and indicate the appropriate safety measures you should take when operating and maintaining the electric chainsaw.



### WARNING!

This is a warning symbol. This symbol is used throughout the user guide whenever there is a risk of personal injury. Ensure that these warnings are read and understood at all times..



Wear hearing protection



Wear eye protection



Wear protective gloves



Do not expose and operate the tool in rain.



Remove the plug from the mains immediately if cable is damaged or cut.



Hold the chain saw with both hands.

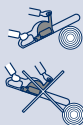

Correct way of operation.



Caution! kick-back! Be careful of kick-back of the machine during work.



Maximum cutting length  
350mm



Brake is engaged and product can not be started or run.



Brake is disengaged and product can be operated.



Guaranteed sound power level



Double insulation



Recycle unwanted materials instead of disposing of them as waste. All tools, hoses and packaging should be sorted, taken to the local recycling centre and disposed of in an environmentally safe way.

# SAFETY INFORMATION

Please read these instructions fully before operating or maintaining your machine

## GENERAL SAFETY



### IMPORTANT!

- The chain is designed exclusively for sawing wood. You may only fell trees if you have received the appropriate training. The manufacturer cannot be held liable for damage caused by improper or incorrect usage.
- Please note that our equipment has not been designed for use in commercial, trade or industrial applications. The warranty will be void if the machine is used in commercial, trade or industrial businesses or for the equivalent purposes
- Read the instructions carefully. Be familiar with the controls and the proper use of the equipment. Always ensure anyone intending to operate this electric chainsaw is fully conversant with the content of this assembly manual prior to assembling, maintaining or operating the chainsaw.
- Keep this operating and maintenance manual in a safe place for future reference.
- Never allow children or people unfamiliar with these instructions to use the electric chainsaw. Local regulations can restrict the age of the operator.
- This appliance is not intended for use by persons (including children) with reduced physical, sensory or mental capabilities, or lack of experience and knowledge, unless they have been given supervision or instruction concerning use of the appliance by a person responsible for their safety.
- Do not touch the saw chain.

## PERSONAL SAFETY



### WARNING!

- Use appropriate tool. This device is only intended for sawing wood for domestic purposes in residential gardens. You may only fell trees if you've received appropriate training. Do not force small tools or attachments to do the job of a heavy duty tool.
- Use personal protective equipment (PPE). Always wear eye protection and ear protection. Protective equipment such as dust mask, chainsaw trousers, non-skid safety shoes, hard hat, or hearing protection used for appropriate conditions will reduce personal injuries.
- Dress appropriately. Use safety footwear, snug-fitting clothing, protective gloves as well as eye, hearing and head protection devices. Wear non-slip footwear when working outdoors and protective hair covering to keep long hair out of the way.
- Stay alert, watch what you are doing and use common sense when operating a power tool. Do not use a power tool while you are tired or under the influence of drugs, alcohol or medication. A momentary lapse of concentration while operating power tools may result in serious personal injury.
- Prevent unintentional starting. Ensure the switch is in the off-position before connecting to power source and/or battery pack, picking up or carrying the tool. Carrying power tools with your finger on the switch or energizing power tools that have the switch on invites accidents.
- Keep all parts of the body away from the

# SAFETY INFORMATION

Please read these instructions fully before operating or maintaining your machine

cutting saw chain. Make sure the switch is off when clearing jammed material. A momentary lapse of concentration while operating the chainsaw may result in serious personal injury.

- Do not overreach and do not cut over shoulder height. Keep proper footing and balance at all times. This enables better control of the power tool in unexpected situations.

## ELECTRICAL SAFETY

- Power tool plugs must match the outlet. Never modify the plug in any way. Do not use any adapter plugs with earthed (grounded) power tools. Unmodified plugs and matching outlets will reduce risk of electric shock.
- Avoid body contact with earthed or grounded surfaces, such as pipes, radiators, ranges and refrigerators. There is an increased risk of electric shock if your body is earthed or grounded.
- Do not expose power tools to rain or wet conditions. Water entering a power tool will increase the risk of electric shock.
- Do not abuse the cord. Never use the cord for carrying, pulling or unplugging the power tool. Keep cord away from heat, oil, sharp edges or moving parts. Damaged or entangled cords increase the risk of electric shock.
- When operating a power tool outdoors, use an extension cord suitable for outdoor use. Use of a cord suitable for outdoor use reduces the risk of electric shock.
- If operating a power tool in a damp location is unavoidable, use a residual

current device (RCD with a tripping current of 30mA or less) protected supply. Use of an RCD reduces the risk of electric shock. NOTE! The term residual current device (RCD) may be replaced by the term "ground fault circuit interrupter (GFCI)" or "earth leakage circuit breaker (ELCB)".

## OPERATIONAL SAFETY

- Keep work areas clean. DO NOT start cutting until you have a clear work area, secure footing, and a planned retreat path from falling trees or branches. Cluttered or dark areas invite accidents.
- Consider work area environment. Do not expose your tool to high humidity or rain.
- Do not use your tool in damp and wet conditions. Keep the work area well lit.
- Keep all bystanders, children, and pets at least 50 feet away. The operator or user is responsible for accidents or hazards occurring to other people or the property.
- Do not operate power tools in explosive atmospheres, such as in the presence of flammable liquids, gases or dust. Power tools create sparks which may ignite the dust or fumes.
- Be certain the parts are fully tightened before operating the tool. Check it periodically for tightness during use to avoid serious injury.
- Risk of cut. Do not touch or try to stop the cutting saw chain when it is moving.
- Disconnect plug from the tool when not in use or when servicing or cleaning.
- Check for damaged parts. Before further use, carefully check the tool for damage.

# SAFETY INFORMATION

**Please read these instructions fully before operating or maintaining your machine**

- Check for alignment of moving parts, binding of moving parts, breakage of parts, mounting and any other condition that may affect its operation.
- Do not use the tool if any parts are damaged or defective. Have any damaged or defective parts repaired or replaced by an authorized service agent. Never attempt any repairs yourself.
- Grip the tool securely. Always hold the tool securely in both hands while working with it.
- Keep handle dry, clean and free from oil and grease. Slippery handles do not allow for safe handling and control of the tool in unexpected situations.
- Keep the cable away from the cutting area. During operation, the cable may be hidden in shrubs and can be accidentally cut by the saw chains.
- Do not overload the tool. Only work in the performance range stated. Do not use tools that do not have sufficient power for heavy jobs. Do not use the tool for any use other than that intended by the manufacturer.
- Do not operate a chainsaw while climbing in a tree. Operation of a chainsaw while up in a tree may result in personal injury.
- Always keep proper footing and operate the chainsaw only when standing on a fixed, secure and level surface. Slippery or unstable surfaces such as ladders may cause a loss of balance or control of the chainsaw.
- When cutting a limb that is under tension, be alert for spring back. When the tension in the wood fibers is released, the spring loaded limb may strike the operator and/or throw the chainsaw out of control.
- Use extreme caution when cutting brush and saplings. The slender material may catch the saw chain and be whipped toward you or pull you off balance.
- Follow instructions for lubricating, chain tensioning and changing accessories. Incorrectly tensioned or lubricated chain may either break or increase the chance for kickback.
- Cut wood only. Do not use chainsaw for purposes not intended. For example; do not use the chainsaw for cutting plastic, masonry or non-wood building materials. Use of the chainsaw for operations different than intended could result in a hazardous situation.
- Maintain a firm grip with thumbs and fingers encircling the chainsaw handles, with both hands on the saw and position your body and arm to allow you to resist kickback forces. Kickback forces can be controlled by the operator, if proper precautions are taken. Do not let go of the chainsaw.
- Kickback may occur when the nose or tip of the guide bar touches an object or when the wood closes in and pinches the saw chain in the cut. Tip contact, in some cases, may cause a sudden reverse reaction, kicking the guide bar rapidly back to towards the operator.
- Either of these reactions may cause you to lose control of the saw which could result in serious personal injury. Do not rely exclusively upon the safety devices built into your saw. As a chainsaw user, you should take several steps to keep your cutting jobs free from accident or injury.

# SAFETY INFORMATION

**Please read these instructions fully before operating or maintaining your machine**

- Carry the chainsaw by the front handle with the chainsaw switched off and away from your body. When transporting or storing the chainsaw, always fit the guide bar cover. Proper handling of the chainsaw will reduce the likelihood of accidental contact with the moving saw chain.
- Do not use the power tool if the switch does not turn it on and off. Any power tool that cannot be controlled with the switch is dangerous and must be repaired.
- Disconnect the plug from the power source before making any adjustments, changing accessories, or storing power tools. Such preventive safety measures reduce the risk of starting the power tool accidentally.
- Cut the wood in correct direction.
- The first-time user should, as a minimum, practice cutting logs on a saw-horse or cradle.
- Before using the chainsaw, be sure to check the chain and bar tension. Do not use the chainsaw if the chain and bar are loose. Also confirm that no abnormalities are present by first test running the tool.

## MAINTENANCE

- Maintain tools with care. Keep tools clean and in good condition for better and safer performance. Follow the instructions for maintenance and changing accessories. Keep handles and switches dry, clean and free from oil and grease.
- Be careful in handling the tool. Keep the blades sharp and clean to improve its working safety and effectiveness. Follow the manufacturer's sharpening and

maintenance instructions for the saw chain. Decreasing the depth gauge height can lead to increased kickback.

- Store idle power tools out of the reach of children and do not allow persons unfamiliar with the power tool or these instructions to operate the power tool. Power tools are dangerous in the hands of untrained users.
- Only use replacement bars and chains specified by the manufacturer. Use only suitable bar (Oregon 140SDEA074) and chain (Oregon 91PJ051X).
- Have your tool repaired by an authorized service agent. This tool is manufactured in accordance with the relevant safety regulations. To avoid danger, electrical appliances must only be repaired by qualified technicians.

## INTENDED USE

- The product is designed for domestic purpose sawing in residential gardens only. The saw is not designed for any other types of application (e.g. cutting of brickwork, plastic or food). Observe the technical data for the maximum cutting capacity. Do not work exceeding the stated maximum capacity.
- This product is intended for private use only, not for any commercial applications. It may not be used for any purposes other than those described.
- Attachments must be used according to the respective functions and in accordance with this instruction manual.

# BOX CONTENT

## PARTS

- |   |                        |    |                        |
|---|------------------------|----|------------------------|
| 1 | Rear grip              | 8  | Rear finger guard      |
| 2 | Front handle           | 9  | Power cable            |
| 3 | Chain break lever      | 10 | Claw stop              |
| 4 | Saw chain              | 11 | Safety lock-off button |
| 5 | SDS chain tension knob | 12 | Cord restrainer        |
| 6 | Chain cover            | 13 | ON/OFF trigger         |
| 7 | Chain bar              | 14 | Oil tank cap           |

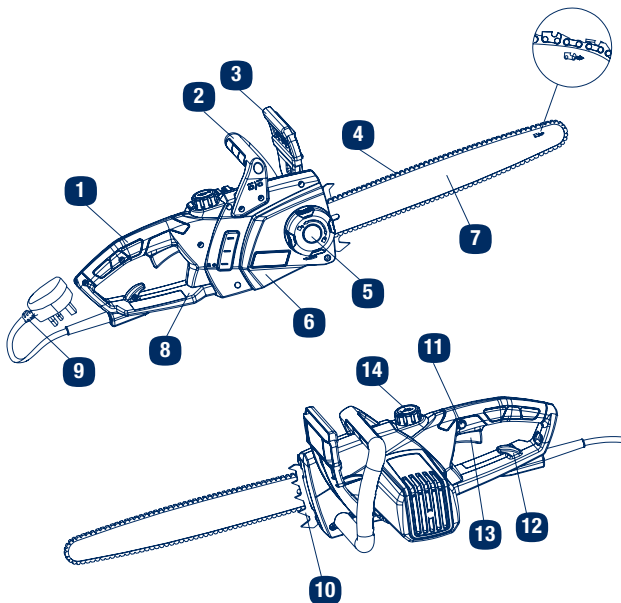

**PLEASE NOTE: THIS PRODUCTS REQUIRES CHAIN LUBRICATION OIL, AVAILABLE IN MOST DIY STORES.**

# PREPARATION



**WARNING!** Always wear protective gloves and clothing when working with the chainsaw and employ only original parts. Pull out the power plug before doing any work on the chainsaw itself-injury hazards!

- i. Remove the electric chainsaw from the box and carefully remove all packaging. Take care not to lose any instructions which may be affixed to parts. These provide important information which will be required while operating the electric chainsaw.
- ii. Do not start before adding chain lubrication oil.

**NOTE!** Always recycle the packaging in accordance with local recycling schemes.

## 1 Tensioning the saw chain



**WARNING!** An incorrectly tensioned chain may break, derail or spring off, leading to danger or injury. Test the electric saw before every start and the chain tension after every hour of sawing.

- i. Ensure that the chain brake is engaged, by pushing the chain brake lever away from the front handle (2).

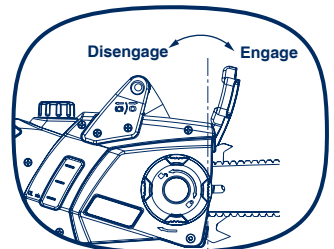

- ii. Adjust the SDS chain tension knob (5) in the "⬆️" direction to increase tension or in the "⬆️" direction to slacken the chain.

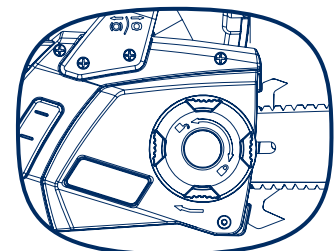

# PREPARATION

iii. Tighten the SDS knob (5). Ensure the chain rotates smoothly on the bar. The chain is correctly tensioned if it does not sag underneath the rail and can be rotated completely around with a gloved hand.

iv. When the saw chain is tensioned with 9N (approx. 1kg), the gap between the saw chain and the guide rail should never be more than 2mm.

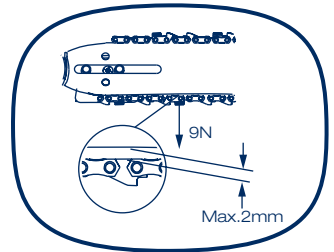

**NOTE!** Do not over tension the chain as this will reduce life of chain bar and motor. With a correctly tensioned chain you will get good cutting performance and a longer life.

## 2 Chain lubrication



**WARNING!** The rail and chain must never be without oil. Operating the electric chainsaw with too little oil, will cause fast overheating of the chain and bar. Smoke development or discoloration of the bar are signs of using too little oil.

**NOTE!** This chainsaw is equipped with an automatic oil system. As soon as the motor is accelerated, the oil also flows faster to the chain bar.

Check the oil fill level and regularly top up with oil. The oil tank holds 100 ml oil. Use chain lubrication oil with low adhesive additive content. The type of motor oil SAE10W-30 is recommended.

# PREPARATION

- i. Unscrew the oil fill cap (14) and fill up with chain oil.
- ii. Wipe off any spilled oil and close the cap again.

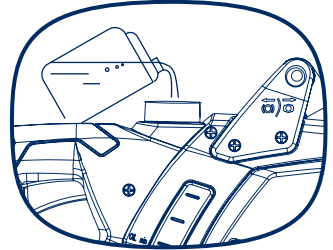

- iii. Switch on the chainsaw pointing it at the ground without touching!
- iv. If an oil trace can be seen, the chainsaw is lubricating.

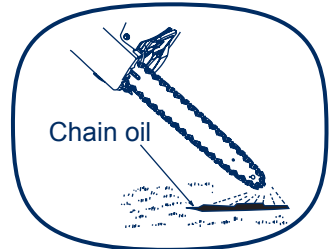

**NOTE!** Never saw when a sufficient chain lubrication is not guaranteed. Before starting work check the oil level in the tank and the oil feeding.

## 3 Check the power supply



**WARNING!** Read all of the instructions of this manual before attempting to connect the power supply for your tool.

If the insulation on a power cable or extension lead is found to be cut or damaged, do not touch it! Disconnect the power supply immediately and have the damaged cable replaced by authorized service agent.

If operating the chainsaw in a damp location is unavoidable, use a residual current device (RCD) protected supply. Use of an RCD reduces the risk of electric shock.

This product is designed to operate on 230-240 VAC 50Hz. The voltage and current must comply with the information on the ratings label

# PREPARATION

**NOTE!** For extension cables up to 15metres, use a wire cross section of 2.5 mm<sup>2</sup>. Use only extension cords suitable for outdoor use, preferably with a high visibility cable colour.

Always unwind all extension cables fully, coiled cables can overheat and reduce the efficiency of your product.

**NOTE!** This electric chainsaw is fitted with a non-rewireable plug. If it is necessary to change the fuse in the plug, the fuse cover becomes lost or damaged; the plug must not be used until a suitable replacement is obtained. A 13amp fuse must be fitted.

i. Before starting, check the oil level using the oil indicator on the side of the machine. If necessary refill with chain oil.

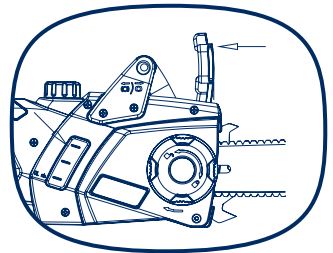

ii. Make sure the on/off switch (13) and safety chain brake trigger (3) is in its off position.

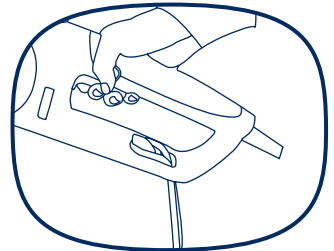

iii. Double the extension cord about a foot from the end. Lead the loop through the hole on the rear handle and hook the loop over the cord restrainer. Gently pull on the cord to ensure that it is firmly attached at the handle.

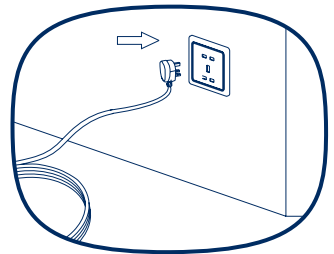

iv. Connect the cord to a suitable socket.

# PREPARATION

## 4 Switching on

- i. Disengage the chain brake, where you pull the chain brake trigger (3) back against the front grip (2).
- ii. Hold the electric chainsaw firmly with both hands, with the right hand on the rear grip and the left hand on the front handle. Thumb and finger must close securely over handles.

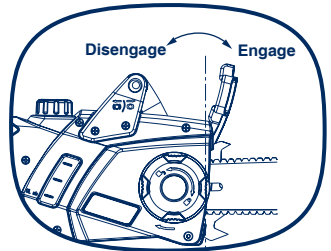

- iii. Switching on, activate the safety lock-off button (11) with the right thumb and then press the On/Off trigger (13).

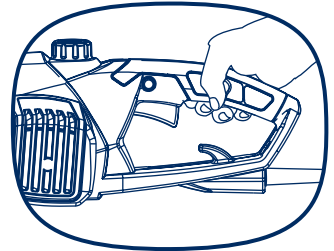

- iv. Release the safety lock-off button(11).

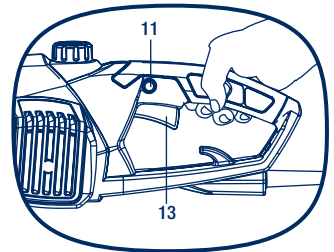

- v. **Switching off**, the chainsaw switches off when you release the On/Off trigger (13). Continuous running of the unit is not possible.

## 5 Checking the chain brake

**NOTE!** The motor cannot be turned on if the chain brake is engaged. Before operation always test if the chain break is working. Do not employ the chain brake as the way to switch off the machine.

# PREPARATION

- i. Thumb and finger must close securely over the handles.  
Turn on the electric chainsaw by pressing the on/off trigger (13).
- ii. Activate the chain brake trigger (3) with running motor by the left hand. Chain should stop abruptly.
- iii. Once the chain brake is working properly, release the on/off switch and the chain brake.

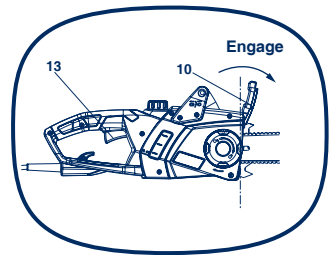
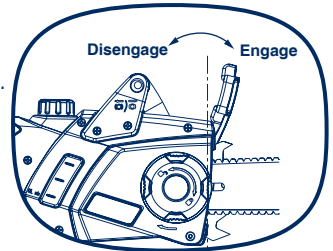

**WARNING! If the chain brake does not function correctly, you must not use the electric chainsaw. A slack saw chain leads to danger of injury.**

# OPERATION



**WARNING!** Always keep a firm grip on the tool with both hands and watch your feet. The saw chain must not contact either the ground or another object during sawing through or after sawing completion.

Make sure that the saw chain does not become jammed in the wood. Do not let the tree trunk break or split off. If the saw chain jams, you should not attempt to pull out the electric chainsaw using power. There is a danger of injury here. Switch off the motor and use a lever or wedge to free the electric chainsaw.

Consider also the precautions against kick-back.

**Kick-back** may occur when the nose or tip of the chain bar touches an object, or when the wood closes in and pinches the saw chain in the cut. If the bar tip contacts, it may cause an extremely fast reverse reaction, kicking the chain bar up and back towards the operator. Pinching the saw chain along the top of the chain bar may push the chain bar rapidly back towards the operator. Either of these reactions may cause you to lose control of the saw, which could result in serious personal injury. Do not rely exclusively upon the safety devices built into your saw. As a chainsaw user, you should take several steps to keep your cutting jobs free from accident or injury.

**NOTE!** With a basic understanding of kickback, you can reduce or eliminate the element of surprise. Sudden surprise contributes to accidents.

## Overcutting

Overcutting begins on the top side of the log with the bottom of the saw against the log. When overcutting use light downward pressure.

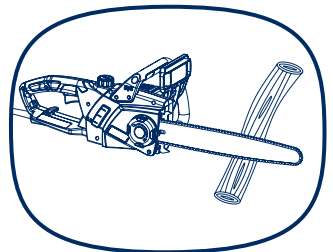

# OPERATION

## Undercutting



**WARNING! Never turn saw upside down to undercut. The saw cannot be controlled in this position**

Undercutting involves cutting on the underside of the log with top of saw against the log. When undercutting use light upward pressure. Hold the saw firmly and maintain control. The saw will tend to push back towards you.

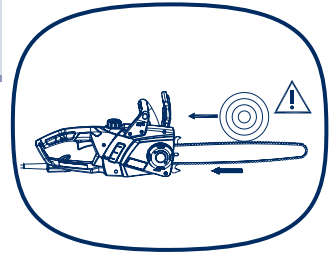

## Cutting logs

### i. Log is lying on the ground:

Saw through the log completely from above and ensure at the end of the cut not to contact the ground.

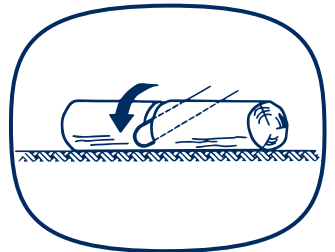

### ii. Log is supported at one end:

Start sawing from the bottom and work your way up (with the upper edge of the bar) a third of the way into the diameter of the trunk to prevent splitting. Then saw from the top downwards with the lower edge of the bar towards the first cut to prevent the bar from becoming jammed in the wood.

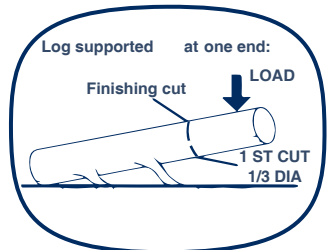

### iii. Log is supported at both ends:

First cut 1/3 of a diameter from the top. Next cut from below using the top of the bar, this will avoid pinching of the bar in wood. Avoid touching the ground with the bar.

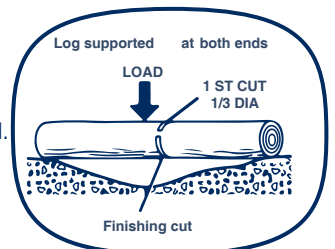

# OPERATION

## iv. Sawing on a support stand

First cut 1/3 of a diameter from the blow, next cut from the top by using the bottom of the bar. See below figure.

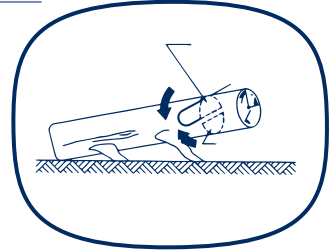

## Limbing

Limbing is removing branches from a fallen tree.

- i. Work slowly, keeping both hands on the chainsaw with a firm grip. Always make sure your footing is secured and your weight is distributed evenly on both feet.
- ii. Leave the larger support limbs under the tree to keep the tree off the ground while cutting.
- iii. Limbs should be cut one at a time. Remove the cut limbs from the work area often to help keep the work area clean and safe.
- iv. Branches under tension should be cut from the bottom up to avoid binding the chain saw.
- v. Keep the tree between you and the chainsaw while limbing. Cut from the side of the tree opposite the branch you are cutting.

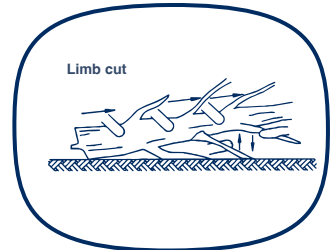

## Pruning



**WARNING! If the limbs to be pruned are above chest height, hire a professional to perform the pruning.**

**Pruning is trimming limbs from a live tree.**

- i. Work slowly, keeping both hands on the chainsaw with a firm grip. Always make sure your footing is secure and your weight is distributed evenly on both feet.
- ii. Do not cut from a ladder, this is extremely dangerous. Leave this operation for professionals.

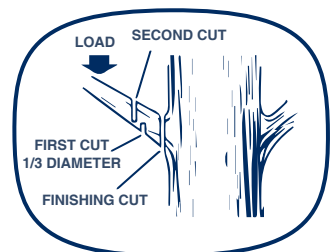

# OPERATION

- iii. Do not cut above chest height as a saw held higher is difficult to control against kickback.
- iv. When pruning trees it is important not to make the finishing cut next to the main limb or trunk until you have cut off the limb further out to reduce the weight. This prevents stripping the bark from the main member.
- v. Under buck the branch 1/3 through for your first cut.
- vi. Your second cut should over buck to drop the branch off.
- vii. Now make your finishing cut smoothly and neatly against the main member so the bark will grow back to seat the wound.

## Felling trees



**WARNING! You may only fell trees if you have received the appropriate training. If a tree starts to fall in the wrong direction, or if the saw gets caught or hung up during the fall, leave the saw and save yourself! Never cut through to the notch when making a backcut. The hinge controls the fall of the tree, this is the section of wood between the notch and backcut.**

Felling a tree-when bucking and felling operations are being performed by two or more persons, at the same time, the felling operation should be separated from the bucking operation by a distance of at least twice the height of the tree being felled. Trees should not be felled in a manner that would endanger any person, strike any utility line or cause any property damage. If the tree does make contact with any utility line, the utility company should be notified immediately.

Before any cuts are started, pick your escape route (or routes in case the intended route is blocked); clear the immediate area around the tree and make sure there are no obstructions in your planned path of retreat. Clear path of safe retreat approximately 135° from planned line of fall. The retreat path should extend back and diagonally to the rear of the expected line of fall.

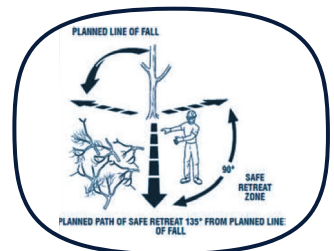

# OPERATION

Before felling is started, consider the force and direction of the wind, the lean and balance of the tree, and the location of large limbs. These things influence the direction in which the tree will fall. Do not try to fell a tree along a line different from its natural line of fall.

The chainsaw operator should keep on the uphill side of the terrain as the tree is likely to roll or slide downhill after it is felled.

Remove dirt, stones, loose bark, nails, staples, and wire from the tree where felling cuts are to be made.

**Notched Undercut.** Cut a notch about 1/3 the diameter of the tree, perpendicular to the direction of fall. Make the cuts of the notch so they intersect at a right angle to the line of fall. This notch should be cleaned out to leave a straight line. To keep the weight of the wood off the saw, always make the lower cut of the notch before the upper cut.

**Felling backcut.** The back cut is always made level and horizontal, and at a minimum of 2 inch. above the horizontal cut of the notch.

**Never cut through to the notch.** Always leave a band of wood between the notch and back cut (approximately 2 in. Or 1/10 the diameter of the tree). This is called “hinge” or “hinge wood”. It controls the fall of the tree and prevents slipping or twisting or shoot-back of the tree off the stump.

On large diameter trees, stop the back cut before it is deep enough for the tree to either fall or settle back on the stump. Then insert soft wooden or plastic wedges into the cut so they do not touch the chain. The wedges can be driven in, little by little, to help jack the tree over.

**NOTE!** When bucking or felling with a wedge, it may be necessary to remove the anti-kickback device to allow the bar to be drawn through the cut. After the cut is complete, the tip should be reinstalled immediately.

As tree starts to fall, stop the chain saw and put it down immediately. Retreat along the cleared path, but watch the action in case something falls your way. Be alert for overhead limbs or branches that may fall and watch your footing.

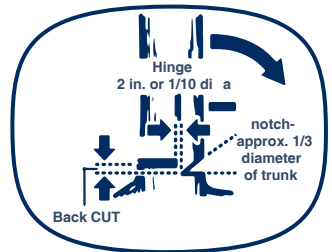
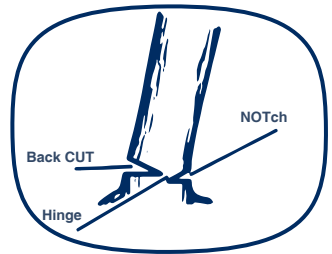
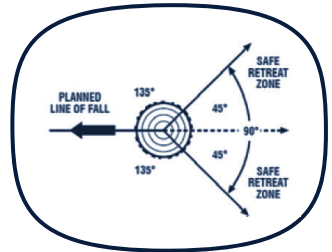

# MAINTENANCE



**WARNING! Always switch the product off and let the product cool down before performing inspection, maintenance and cleaning work!**

This chainsaw meets all current legislation requirements, in order to avoid injuries while repairing; every repair has to be carried out by a qualified member of staff in an authorized service centre.

## General

- i. Clean the product with a slightly damp cloth and pH-neutral soap. Use a brush for areas that are hard to reach.
- ii. In particular clean the air vents and chain guide on the bar after every use with a cloth and brush.
- iii. Remove stubborn dirt with high pressure air (max. 3 bar).
- iv. Check for worn or damaged parts. Replace worn parts as necessary or contact the aftersales support for repair before using the product again.
- v. Regularly check for obvious defects such as loose, dislodged or damaged cutting device, loose fixings and worn or damaged components.
- vi. Check that covers are undamaged and correctly fitted. Carry out necessary maintenance or repairs before using the product.
- vii. Regularly apply lubricant to the chain surface.
- viii. Ensure that the oil reservoir and the oil filter are clean.

## Replace the chain

**NOTE!** It is very important for smooth and safe operation to cut with a sharp chain. The chain needs replacing when:

- Sawdust start to clog up the chain.v
- Cutting requires extra force.
- The chainsaw does not cut straight and clean.
- Vibration increases.

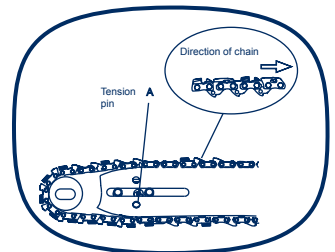

# MAINTENANCE

- i. Remove the SDS knob(5) and the chain cover
- ii. Fit the chain around the bar ensuring that the direction of the chain is as depicted in the picture on the bar. Fit the chain on the sprocket.
- iii. Fit the chain cover to the power unit. While lifting the tip of guide bar, tighten the bar knob securely (clockwise). Hand tighten only!
- iv. While holding up the tip of the bar, adjust the chain tension by turning the tension knob until the chain engages in the bar channel. When tensioned correctly it should be possible to pull one full chain link free of the bar channel with ease.
- v. Tighten the tension knob securely finger tight. Then check the chain for smooth rotation and proper tension while moving it by hand. If necessary, loosen the chain cover.

**NOTE!** A new chain will expand its length during the first period of use. Check and re-adjust the tension frequently as a loose chain can easily derail or cause rapid wear of itself and the chain bar. If the saw chain is **TOO LOOSE** or **TOO TAUT**, the Vdrive wheel, the chain bar, the chain and the crank shaft bearing will suffer premature wear.

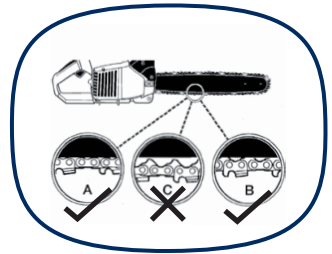
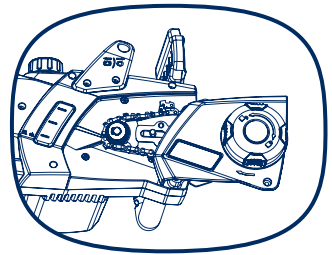

## Chain sharpening



**WARNING! Wear safety gloves when working on the chainsaw and close to it!**

Periodically sharpen the blades as follows:

- i. Disconnect the cord from the mains supply.
- ii. Wear protective gloves.
- iii. Ensure the chain is correctly tensioned and not too loose.

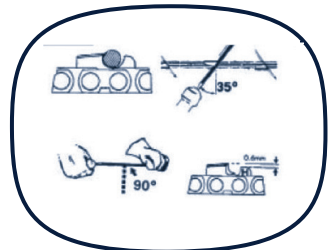

# MAINTENANCE

- iv. Engage the chain brake (10) to lock the chain on the bar (“Engage”position) when sharpening.
- v. Uses a round file for chain sharpening. Diameter equivalent to 1.1times the cutting tooth depth.
- vi. File at a horizontal angle  $35^{\circ}$ to the bar.
- vii. File from inside towards outside of the tooth only.
- viii. Sharpen each tooth equally by using the same number of strokes.
- ix. File at an angle of  $90^{\circ}$  to the bar.
- x. Check the safety depth gauge height in intervals while sharpening. Use depth gauge measuring instrument to check the height of the depth gauge.

## Cleaning the guide bar and lubricating the sprocket nose

Regularly inspect the bearing surfaces of the guide bar for damage, and clean them with a suitable tool.

If the saw is used intensively it will be necessary to lubricate the return sprocket bearings regularly(once a week).To do this,first thoroughly clean the 2mm hole at the tip of the guide bar, and then press in a small amount of multi-purpose grease.

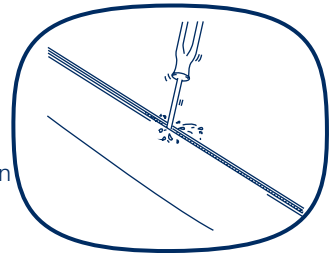

## Check the chain bar

- i. Reverse the bar occasionally to prevent partial wear.
- ii. The bar rail should always have parallel internal faces (see diagram). Check for wear of the bar rail. Apply a ruler to the bar and the outside of a cutter. If a gap is observed between them, the rail is normal. Otherwise, the bar rail is worn. Such a bar needs to be corrected or replaced.

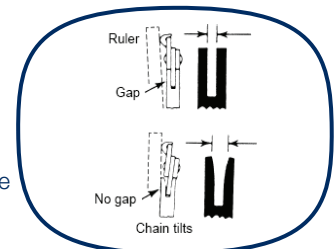

# MAINTENANCE

## UK plug

If you need to replace the fitted plug, then this must be replaced using a BS1363/A Mains plug fitted with a BS1362 approved fuse of identical value to the original fuse. Proceed as follows:

**IMPORTANT:** The wires in the mains lead are coloured in accordance with the following code:

Blue – Neutral, Brown – Live

In case the colours of the wires in the mains lead don't match the colour marking on the terminals, please proceed as follow.

Connect the blue wire to the terminal marked N (Neutral) or coloured black. The brown wire must be connected to the terminal marked L or coloured red.

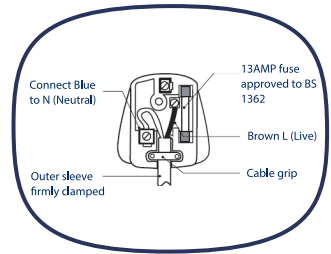

---

---

## Storing

- i. Clean the product as described above.
- ii. Store the product and its accessories in a dark, dry, frostfree, well-ventilated place.
- iii. Always store the product in a place that is inaccessible to children. The ideal storage temperature is between 10-30°C.
- iv. We recommend using the original package for storage or covering the product with a suitable cloth or enclosure to protect it against dust.

---

---

## Transport

- i. Switch the product off and disconnect it from power supply before transporting it anywhere.
  - ii. Always carry the product on its gripping surfaces.
  - iii. Protect the product from any heavy impact or strong vibrations which may occur during transportation in vehicles.
  - iv. Secure the product to prevent it from slipping or falling over
- 
-

## Disposal

### Disposing of the machine



Machines which are labeled with this symbol  must not be disposed of in household rubbish. You must dispose of such electrical and electronic appliances separately.

Please check with your local authority about the possibilities for correct disposal. You will thus help to avoid that damaging into the environment.

### Disposing of the packaging

The packaging consists of cardboard and correspondingly marked sheets that can be recycled. Make these materials available for recycling.

---

# TECHNICAL DATA

<b>Model</b>	<b>CS2400</b>
Motor Voltage	230-240V ~/50Hz
Power Input	2400W
Chain speed	15m/s
Insulation class	class II
Net weight	5.35Kg
Type of saw chain	Oregon 91P056x(16 in.)
Type of guide bar Oregon	160SDEA041(16 in.)
Measured sound pressure level	90.4dB (A), k=3 dB (A)
Measured sound power level	103.9dB (A), k=2.36dB (A)
Guaranteed sound power level	106dB (A)
Vibration	7.156 m/s <sup>2</sup> , k=1.5 m/s <sup>2</sup>

<b>Part number</b>	<b>Accessories</b>
160SDEA041	Chain
91P056x	Bar
8094-950001	SDS knob
8069-131001	Oil cap
visit our website for more information on accessories.	

## **No power**

- Check the plug socket, cable, line and plug, where appropriate, have it repaired by a certified electrician.
- If any of the parts are defective, such as On/Off switch / motor etc, call after sales support.
- Hand guard chain break might be engaged
- Please contact after sales support at 01904 727505.

## **Inferior cutting performance**

- Check if incorrectly mounted saw chain, if so, re-assemble.
- Check if saw chain is blunt. Please replace the chain.
- Check the chain tension (see page 21 for instructions).
- Please contact after sales support at 01904 727505.

## **Saw runs with difficulty, chain comes off**

- Check the chain tension (see page 21 for instructions).
- Please contact after sales support at 01904 727505.

## **Chain becomes hot, smoke development during sawing, discoloration of the rail**

- Check lubrication oil level and where appropriate. Refill with chain oil. Check automatic oil system and, where appropriate, clean the oil outflow duct or have it repaired by customer service.
- Please contact after sales support at 01904 727505.

# WARRANTY

---

If your device develops a fault, please don't hesitate to contact our customer service department on 01904 727505, we can usually solve 80% of problems via telephone.

1. These warranty terms cover additional warranty rights and do not affect your statutory warranty rights. All our products are covered by a two year manufacturer warranty unless this product was registered within 28 days of purchase via [www.spearandjackson-power.com](http://www.spearandjackson-power.com) and therefore obtained an additional 12 month warranty.
2. Claims must be accompanied by a Proof of Purchase. This must be in the form of a Sales receipt or Bank statement and must show that the product has been purchased within the warranty period as described under point 1, from the retailer that it was originally bought from. Please keep your receipt safe or staple it to the back of this manual for future reference.
3. Our warranty covers problems caused by material or manufacturing defects, and will result in the repair of these defects or replacement of the device with a like for like or similar article.
4. Our devices have not been designed for commercial, trade or industrial applications, any signs of use of the equipment in these application or equivalent activities, invalidates the warranty.
5. The following are also excluded from our warranty:
  - A. Faults due to accidents, customer misuse or unauthorized repairs
  - B. Consumable Parts such as chain, bar, and other accessories that are compatible with the product.
  - C. Failure due to lack of routine maintenance.
  - D. Failure as a result of not using the equipment in accordance with the manual and safety instructions
  - E. The adjustment of cables, drives gears or motors.

Warranty claims should be submitted before the end of the warranty period, see point 1, but a paid service exists for repairs commissioned after this period. The original warranty period remains applicable to the device even if repairs are carried out or parts are replaced. In such cases, the work performed or parts fitted will not result in an extension of the warranty period, and no new warranty will become active for the work performed or parts fitted.

6. Please keep your sales receipt in a safe place. If covered by our warranty, your device will either be repaired under the terms of warranty or we will send you a replacement device.

This device may be re-conditioned, like for like or an upgraded replacement.

If you have any problems or questions concerning your garden power tool, please contact our after sales service at 01904 727505 or visit [www.spearandjackson-power.com](http://www.spearandjackson-power.com).

# EC DECLARATION OF CONFORMITY

## We

SUMEC UK Co.,Ltd.  
Unit A&B Escrick Business Park  
Escrick, York YO19 6FD

## Declare that the product

Electric chain saw  
Model No: CS2400  
Function: Saw Wood  
Serial number : EP00001~EX99999

## Complies with the following directives:

EMC Directive: 2014/30/EU  
Machinery Directive: 2006/42/EC  
Low Voltage Directive 2006/95/CE  
Noise Directive: 2000/14/EC  
RoHS Directive: 2011/65/EU  
WEEE Directive 2012/19/EU

## Standards conform to:

EN 60745-1:2009+A11:2010  
EN 60745-2-13:2009+A1:2010  
EN 55014-1:2006+A1:2009+A2:2011  
EN 55014-2:1997+A1:2001+A2:2008  
EN 61000-3-2:2006+A1:2009+A2:2009  
EN 61000-3-3:2008  
EN 61000-3-11:2000

## We additionally confirm the following in accordance with the 2000/14/EC emissions guideline:

Conformity Assessment Procedure as Per Annex II,  
Measured sound pressure level LpA: 90.4dB(A), k=3dB(A)  
Measured sound power level LwA: 103.9dB(A), K=2.36dB(A)  
Guaranteed sound power level LwA: 106dB(A)

Authorized Signatory  
Date: 27-02-2017 \_\_\_\_\_

Signature: M. Hall

Name:  
General Manager  
Sumec UK Co., Ltd.

