



SPEAR & JACKSON

GRASS TRIMMER

300W
GT300

**ORIGINAL
INSTRUCTION
MANUAL**



AFTERSALES SERVICE
01904 727505
MON-FRI 9am-5pm SAT/SUN 11am-4pm
www.spearandjackson-power.com



Important - Please read these instructions fully before operating or maintaining your grass trimmer

These instructions contain important information that will help you get the best from your grass trimmer, protecting your power tool investment.

THANK YOU!

Dear Customer,

Thank you for choosing a Spear and Jackson grass trimmer.

Spear and Jackson was founded in 1760 in the city of Sheffield, which is world famous for the production of steel, cutlery and garden and hand tools.

Through continuous innovation and the use of new technologies and materials, Spear and Jackson has gained an enviable reputation as a supplier of reliable, high performance and high quality products designed to make your work in the garden as easy and enjoyable as possible.

3 YEARS GUARANTEE

As a testament to the quality of our products, we offer a free extension of the standard 2 years manufacturer's warranty for all registered products. Simply register your product within 28 days of purchase via www.spearandjackson-power.com to extend the standard manufacturer's warranty by an additional 12 months. After registering your product, your garden power tool will be covered for parts and labour for 3 years from the date of purchase, subject to the terms of the warranty. If you do not register your product, it is important to retain your proof of purchase.

7 DAYS A WEEK TECHNICAL SUPPORT

We want you to get the best out of your products. Our easy-to-read instruction manual guides you with best practice use and maintenance tips. You can also visit www.spearandjackson-power.com for online help, general tips and useful videos about your garden product. However if you prefer to speak to one of technicians please call **01904 727505, Mon-Fri 9am-5pm and Sat/Sun 11am-4pm**, we can solve around 80% of questions directly over the phone.

We hope you enjoy your product and we look forward to any feedback, as this allows us to develop even better products for the future.

CONTENTS

Safety Information	04
Description of symbols	04
General safety	05
Safety warnings	05
Personal safety	06
Operational safety	07
Maintenance and storage safety	07
Intended use	08
Box Content / Parts	09
Assembly	10
Unpacking	10
Safety guard assembly	10
Front handle assembly	10
Shaft assembly	11
Connect to main supply	11
Operation	12
General operation	12
Switching on/off	12
Bump line feeding	12
Trimming	13
Tips	13
Maintenance	14
Replacing the spool	14
Winding the line	14
UK plug	15
Storage	16
Transportation	16
After use	16
Recycling and disposal	16
Technical Data	17
Troubleshooting	19
Warranty	20
EC DECLARATION OF CONFORMITY	21

SAFETY INFORMATION

Please read these instructions fully before operating or maintaining your machine

DESCRIPTION OF SYMBOLS

The following warning symbols appear throughout this manual and indicate the appropriate safety measures you should take when operating and maintaining the grass trimmer.



IMPORTANT!

Please read all of the safety and operating instructions carefully before using this tool. Please pay particular attention to all sections of this user guide that carry warning symbols and notices.



WARNING!

This is a warning symbol. This symbol is used throughout the user guide whenever there is a risk of personal injury. Ensure that these warnings are read and understood at all times.



Wear hearing protection.



Wear eye protection.



Wear respiratory protection.



Disconnect the mains plug immediately if the cable is damaged, has been badly twisted or is completely cut through and in the event that the device is left unattended for a short time.



There is a risk that some objects could be thrown out by the shredder. Keep bystanders away.



Guaranteed sound power level.



Warning! Cutting device continues to rotate after the motor is switched off.



Do not expose the product to rain or wet conditions (moisture).



Warning! Keep other people out of working area during operation. A distance of at least 15 m must be observed.



Double insulations, Class II appliance.



Waste electrical products should not be disposed of with household waste. Please recycle where facilities exist. Check with your local authority or retailer for recycling device.



The product complies with the applicable European directives and an evaluation method of conformity for these directives was done.

SAFETY INFORMATION

Please read these instructions fully before operating or maintaining your machine

GENERAL SAFETY



IMPORTANT!

- Keep this instruction manual in a safe place for future reference.
- Read the instructions carefully. Be familiar with the controls and the proper use of the equipment.
- Never use the machine while people, especially children, or pets are nearby. Keep in mind that the operator or user is responsible for accidents or hazards occurring to other people or their property.
- This appliance is not intended for use by persons (including children) with reduced physical, sensory or mental capabilities, or lack of experience and knowledge, unless they have been given supervision or instruction concerning use of the appliance by a person responsible for their safety.
- Children should be supervised to ensure that they do not play with the appliance.

SAFETY WARNINGS

WORK AREA SAFETY

- Keep work area clean and well lit. Cluttered or dark areas invite accidents.
- Do not operate power tools in explosive atmospheres, such as in the presence of flammable liquids, gases or dust. Power tools create sparks which may ignite the dust or fumes.
- Keep children and bystanders away while operating a power tool. Distractions can cause you to lose control.

ELECTRICAL SAFETY

- Power tool plugs must match the outlet. Never modify the plug in any way. Do not use any adapter plugs with earthed (grounded) power tools. Unmodified plugs and matching outlets will reduce risk of electric shock.
- Avoid body contact with earthed or grounded surfaces, such as pipes, radiators, ranges and refrigerators. There is an increased risk of electric shock if your body is earthed or grounded.
- Do not expose power tools to rain or wet conditions. Water entering a power tool will increase the risk of electric shock.
- Do not abuse the cord. Never use the cord for carrying, pulling or unplugging the power tool. Keep cord away from heat, oil, sharp edges or moving parts. Damaged or entangled cords increase the risk of electric shock.
- When operating a power tool outdoors, use an extension cord suitable for outdoor use. Use of a cord suitable for outdoor use reduces the risk of electric shock.
- If operating a power tool in a damp location is unavoidable, use a residual current device (RCD) protected supply. Use of an RCD reduces the risk of electric shock.

POWER TOOL USE AND CARE

- Do not force the power tool. Use the correct power tool for your application. The correct power tool will do the job better and safer at the rate for which it was designed.
- Do not use the power tool if the switch does not turn it on and off. Any power tool that cannot be controlled with the switch is dangerous and must be repaired.

SAFETY INFORMATION

Please read these instructions fully before operating or maintaining your machine

- Disconnect the plug from the power source and/or the battery pack from the power tool before making any adjustments, changing accessories, or storing power tools. Such preventive safety measures reduce the risk of starting the power tool accidentally.
 - Store idle power tools out of the reach of children and do not allow persons unfamiliar with the power tool or these instructions to operate the power tool. Power tools are dangerous in the hands of untrained users.
 - Maintain power tools. Check for misalignment or binding of moving parts, breakage of parts and any other condition that may affect the power tool's operation. If damaged, have the power tool repaired before use. Many accidents are caused by poorly maintained power tools.
 - Keep cutting tools sharp and clean. Properly maintained cutting tools with sharp cutting edges are less likely to bind and are easier to control.
 - Use the power tool, accessories and tool bits etc. in accordance with these instructions, taking into account the working conditions and the work to be performed. Use of the power tool for operations different from those intended could result in a hazardous situation.
- you are tired or under the influence of drugs, alcohol or medication. A moment of inattention while operating power tools may result in serious personal injury.
- Use personal protective equipment. Always wear eye protection. Protective equipment such as dust mask, non-skid safety shoes, hard hat, or hearing protection used for appropriate conditions will reduce personal injuries.
 - Prevent unintentional starting. Ensure the switch is in the off-position before connecting to power source and/or battery pack, picking up or carrying the tool. Carrying power tools with your finger on the switch or energising power tools that have the switch on invites accidents.
 - Remove any adjusting key or wrench before turning the power tool on. A wrench or a key left attached to a rotating part of the power tool may result in personal injury.
 - Do not overreach. Keep proper footing and balance at all times. This enables better control of the power tool in unexpected situations.
 - Dress properly. Do not wear loose clothing or jewellery. Keep your hair, clothing and gloves away from moving parts. Loose clothes, jewellery or long hair can be caught in moving parts.
 - If devices are provided for the connection of dust extraction and collection facilities, ensure these are connected and properly used. Use of dust collection can reduce dust-related hazards.

PERSONAL SAFETY

- Stay alert, watch what you are doing and use common sense when operating a power tool. Do not use a power tool while

SAFETY INFORMATION

Please read these instructions fully before operating or maintaining your machine

OPERATIONAL SAFETY

- Use the product only in daylight or good artificial light.
- Never operate the product with damaged guards or shields or without guards or shields in place.
- Keep hands and feet away from the cutting attachment at all times and especially when switching on the motor.
- Before use check the controls and proper use of the product.
- Before using the product and after any impact, check for signs of wear or damage and repair as necessary.
- Always disconnect the product from the power supply (i.e. remove the plug from the power supply or the battery pack)
 - whenever leaving the product unattended;
 - before clearing a blockage;
 - before checking, cleaning or working on the product
 - after striking a foreign object;
 - whenever the product starts vibrating abnormally.
- Take care against injury to feet and hands from the cutting attachment.
- Always ensure that the air vents are kept clear of debris.
- After extending new cutter line always return the product to its normal operating position before switching on.
- Never fit metal cutting elements.
- Never replace non-metallic cutting means with metallic cutting means.
- Never use replacement parts or accessories not provided or recommended by the manufacturer.
- The product should be supplied via a residual current device (RCD) with a tripping current of not more than 30 mA.
- Avoid using the product in bad weather conditions especially when there is a risk of lightning.
- Position the cord so that it will not be caught by the cutting attachment during operation.
- Disconnect from the power supply when the cord becomes damaged or tangled.
- If the cord becomes damaged during use, disconnect the cord from the supply immediately. **DO NOT TOUCH THE CORD BEFORE DISCONNECTING THE SUPPLY.**
- Do not use the product if the cord is damaged or worn.
- Warning! The cutting elements continue to rotate after the product is switched off.
- Keep the extension cord away from cutting elements.
- Only use an extension cord not lighter than:
 - if rubber insulated: ordinary tough rubber sheathed flexible cord (code designation 60245 IEC 53);
 - if polyvinyl chloride insulated: ordinary polyvinyl chloride sheathed flexible cord (code designation 60227 IEC 53).
- Do not expose the product to rain.

MAINTENANCE AND STORAGE SAFETY

- Disconnect the product from the power supply (i.e. remove the plug from the power

SAFETY INFORMATION

Please read these instructions fully before operating or maintaining your machine

supply or the battery pack) and check for damage after use.

- Disconnect the product from the power supply (i.e. remove the plug from the power supply or the battery pack) before carrying out maintenance or cleaning work.
- Use only the manufacturer's recommended replacement parts and accessories.
- Inspect and maintain the product regularly. Have the product repaired only by an authorised service centre or similar qualified specialist.
- When not in use, store the product out of the reach of children.
- Have your power tools serviced by a qualified repair person using only identical replacement parts. This will ensure that safety of the power tool is maintained.

INTENDED USE

This electric grass trimmer is designed for domestic use only: to trim grass, lawn edges and light foliage.

This machine is not designed for heavy duty or commercial use.

Any use of the machine that deviates from its intended use and is not included in these instructions is considered unauthorized use and relieves the manufacturer from his or her legal liability.

BOX CONTENT

PARTS

- 1 Cable
- 2 Main handle
- 3 On/off Switch
- 4 Cable retainer
- 5 Front handle
- 6 Safety Guard
- 7 Screw x3
- 8 Line trimming head

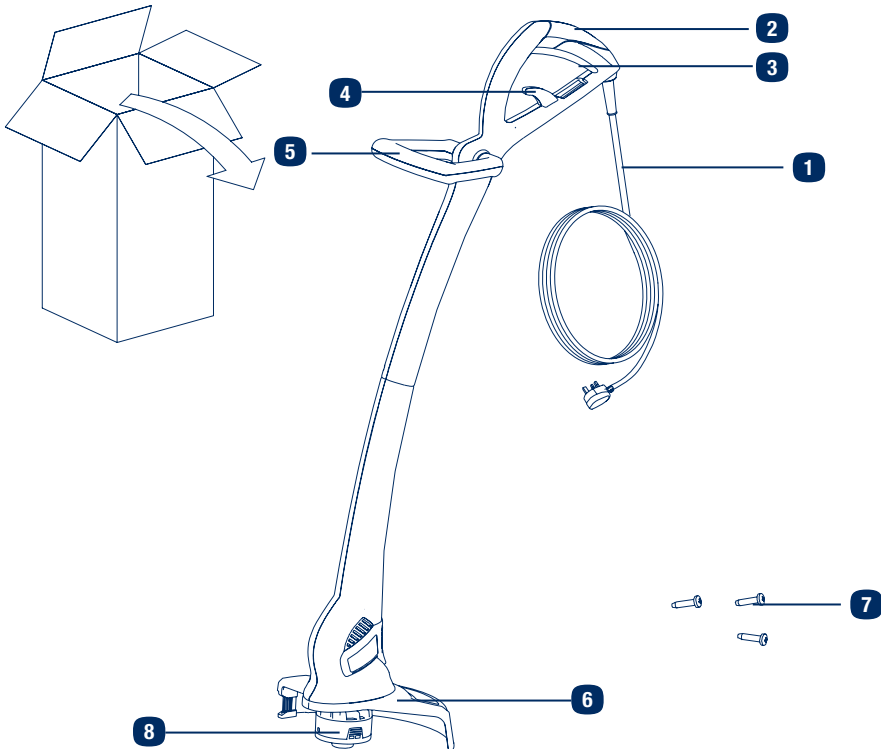

If there are any parts missing, please call the customer helpline on 01904 727505

ASSEMBLY

1 Unpacking

- i. Unpack all parts and lay them on a flat, stable surface.
- ii. Remove all packing materials and shipping devices if applicable.
- iii. Make sure the delivery contents are complete and free of any damage. If you find that parts are missing or show damage do not use the product but contact the aftersales service within 28 days of purchase. Using an incomplete or damaged product represents a hazard to people and property.
- iv. Ensure that you have all the accessories and tools needed for assembly and operation. This also includes suitable personal protective equipment.

2 Safety guard assembly

- i. Align the guard (6) to the trimmer head and place it over it.
- ii. Secure the guard with the screws.

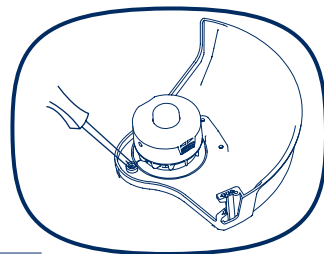

3 Front handle assembly

- i. Loosen the bolt with a screw driver from the front handle.
- ii. Align the front handle to the support and place it onto it.
- iii. Insert the bolt from the right through the opening. And tighten the bolt with a screw driver.

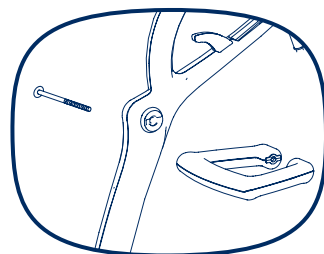

ASSEMBLY

4 Shaft assembly

- i. Fix the lower shaft into the upper shaft.

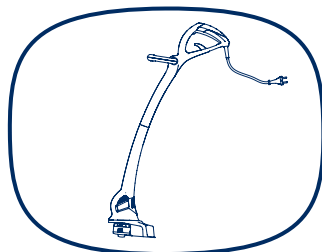
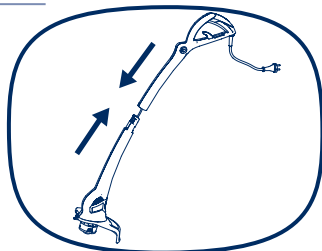

5 Connect to main supply

- i. Make sure the on/off switch is in its off position.
- ii. Double the extension cord, about 3cm from the end. Lead the loop through the hole on the rear safe guard and hook the loop over the cord strain relief. Gently pull on the cord to ensure that it is firmly attached.
- iii. Connect the plug to the mains socket - this product runs on 240V.

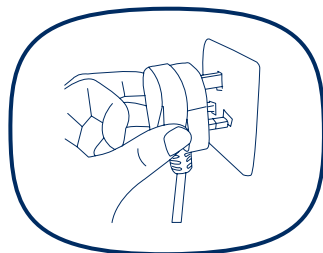
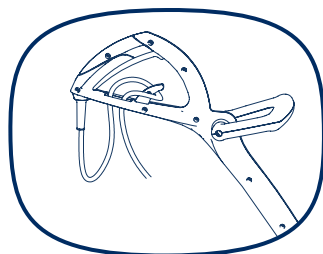

OPERATION

General operation

- i. Check the product, its power cord and plug as well as accessories for damage before each use. Do not use the product if it is damaged or shows wear.
 - ii. Double check that accessories or cutting device are properly fixed.
 - iii. Always hold the product by its handles. Keep the handles dry to ensure safe support.
-
-

Switching on/off

- i. Press the on/off switch (3) to turn the product on.
 - ii. Release the on/off switch (3) to turn the product off.
-
-

Bump line feeding

- i. While the line spool is running at full speed, tap its underside briefly against the ground.
 - ii. If the spool lines are still not sufficiently extended, tap the underside against the ground again.
 - iii. If the line has already become too short, it will no longer be extended by pressing the underside against the ground. You must pull it out from the line spool by hand.
-
-

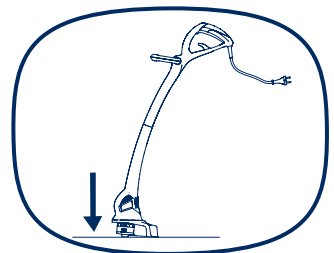

OPERATION

Trimming

- i. Ensure the knife protector label is removed before use.
Ensure you wear gloves when removing this label.
- ii. Hold the grass trimmer firmly, keeping your balance with feet slightly apart. Alter the height of the product if needed to ensure an upright posture.
- iv. Hold the trimmer head just above the ground at an angle of approximately 30°.
- v. Move the product slowly from side to side in a swinging motion.
- vi. Ensure the cutting device remains clean and free from off-cuts that may cause it to jam. Check regularly. Release the on/off switch and disconnect the product from the power supply before checking.
- vii. Trim longer grass in stages; do not cut long grass in one cut. For the best results, cut longer grass in steps.

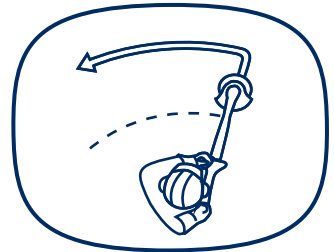
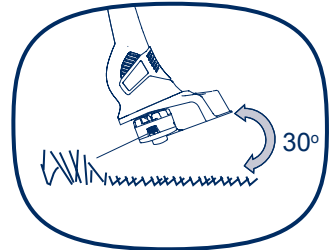

Tips

- i. For best results, do not cut wet grass because it tends to stick to the cutting head and guard, prevents proper discharge of grass trimmings, and could cause you to slip and fall.
- ii. Do not allow the spool cover to drag on the ground or other surfaces.
- iii. Pay special attention when performing the work close to trees and bushes. The cutting head could damage sensitive bark, and damage fence posts.

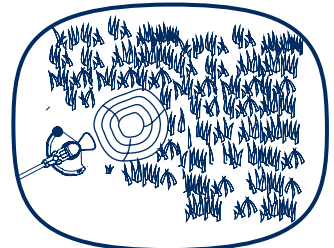

MAINTENANCE

This product does not contain any parts that can be repaired by the consumer. Contact an authorised service centre or a similarly qualified person to have it checked and repaired.

Replacing the spool

NOTE: Before replace the spool, make sure the mains plug is disconnected from the unit.

- i. Press together both locking device tabs on the spool cover and remove the cover.
- ii. Remove the old spool from the spool cover
- ii. Clean out any dirt or grass residue.

- iii. Put the new spool in the spool housing, thread the line into the hole.

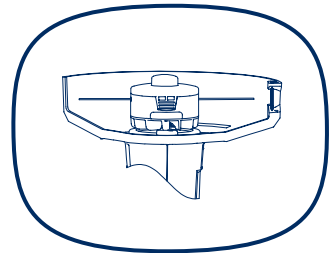
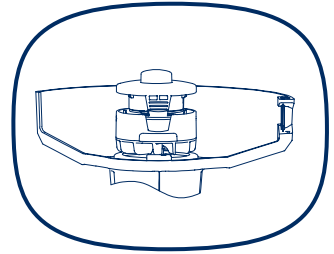

Warning! Please always keep the spring in position.

Winding the line

NOTE: Should you wish to wind the line yourself, the instructions are provided below:

Self-winding, however, is NOT recommended because if the line is not wound properly it can cause the trimmer's feed system to malfunction. For this reason, users are strongly urged to purchase the pre-wound spool.

MAINTENANCE

- i. Hold the loose ends of the line together with one hand, find the center of the line with the other hand and hook this center loop into the groove on the spool.

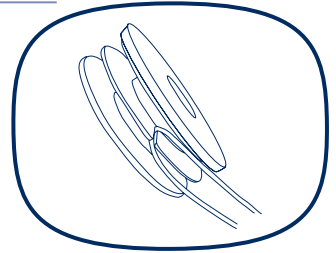

- ii. Wind the line following the directional arrows on the spool housing and hook the two ends into the side grooves.

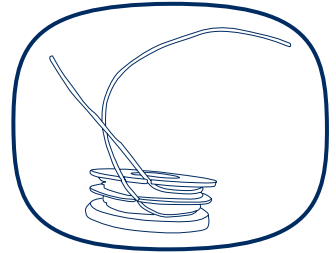

UK plug

If you need to replace the fitted plug, then this must be replaced using a BS1363/A Mains plug fitted with a BS1362 approved fuse of identical value to the original fuse. Proceed as follows:

IMPORTANT: The wires in the mains lead are coloured in accordance with the following code:

Blue – Neutral, Brown – Live In case the colours of the wires in the mains lead don't match the colour marking on the terminals, please proceed as follow.

Connect the blue wire to the terminal marked N (Neutral) or coloured black. The brown wire must be connected to the terminal marked L or coloured red.

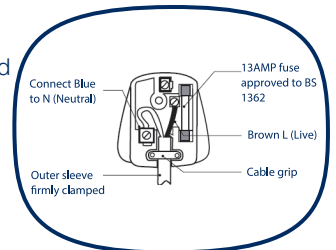

MAINTENANCE

Storage

- i. Store the product and its accessories in a dry, frost-free place.
 - ii. Always store the product in a place that is inaccessible to children.
The ideal storage temperature is between 10 and 30°C.
-
-

Transportation

- i. Switch the product off and disconnect from power supply before transporting it anywhere.
 - ii. Protect the product against scratching and secure it to avoid damage from impact.
-
-

After use

- i. Switch the product off, disconnect it from the power supply and let it cool down.
 - ii. Check, clean and store the product as described below.
-
-

Recycling and disposal

- i. Waste electrical products should not be disposed of with household waste. Please recycle where facilities exist. Check with your Local Authority or local store for recycling advice.
- ii. The product comes in a packaging that protects it against transportation damage. Keep hold of the packaging until you are sure that all the parts have been delivered and the product is functioning properly. Recycle the packaging afterwards.



TECHNICAL DATA

Model	GT300
Input voltage rating	230-240V~, 50Hz
Input power	300W
No load speed	12000/min
Trimming line	Ø 1.2 mm, length 2X3m
Cutting capacity	250mm
Weight	1.58kg
Dimensions	92x50x27cm

Part number	Accessories
GT015-21	Front handle
GB/T818-2000	Front handle bolt
GT015-14	Trimmer spool
GT015-20	Guard

Sound values

Sound pressure level LpA: 76.3dB(A)

Sound power level LWA: 95.08 dB(A)

Uncertainty K: 0.38dB(A)

Guaranteed sound power level LWA: 96 dB(A)

Vibration values

Hand arm vibration ah: 4 m/s²

Uncertainty K: 1.5 m/s²

TECHNICAL DATA

The sound values have been determined according to noise test code given in EN 50636-2-91, using the basic standards EN ISO 11201 and EN ISO 3744.

The sound intensity level for the operator may exceed 80 dB(A) and ear protection measures are necessary.

The declared vibration value has been measured in accordance with a standard test method (according to EN 50636-2-91) and may be used for comparing one product with another. The declared vibration value may also be used in a preliminary assessment of exposure.

WARNING! Depending on the actual use of the product the vibration values can differ from the declared total! Adopt proper measures to protect yourself against vibration exposures! Take the whole work process including times the product is running under no load or switched off into consideration!

Proper measures include among others regular maintenance and care of the product and cutting attachments, keeping hands warm, periodical breaks and proper planning of work processes!

TROUBLESHOOTING

Product does not start

- Not connected to power supply
- Power cord or plug is defective
- Other electrical defect to the product
- If any of the parts are defective, such as On/Off switch / motor etc.

Please contact after sales support at 01904 727505.

Product does not reach full power

- Please contact after sales support at 01904 727505
- Power source (e.g. generator) has too low a voltage
- Air vents are blocked

Unsatisfactory result

- Please contact after sales support at 01904 727505

WARRANTY

If your device develops a fault, please don't hesitate to contact our customer service department on 01904 727505, we can solve 80% of problems via the phone.

1. These warranty terms cover additional warranty rights and do not affect your statutory warranty rights. All our products are covered by a two year manufacturer warranty unless this product was registered within 28 days of purchase via www.spearandjackson-power.com and therefore obtained an additional 12 month warranty.
2. Claims must be accompanied by proof of purchase. This must be in the form of a sales receipt or bank statement and must show that the product has been purchased within the warranty period as described under point 1, from the retailer that it was originally bought from. Please keep your receipt safe or staple it to the back of this manual for future reference.
3. Our warranty covers problems caused by material or manufacturing defects, and will result in the repair of these defects or replacement of the device with a like for like or similar article.
4. Our devices have not been designed for commercial, trade or industrial applications, any signs of use of the equipment in these application or equivalent activities, invalidates the warranty.
5. The following are also excluded from our warranty:
 - A. Faults due to accidents, customer misuse or unauthorized repairs
 - B. Consumable Parts such as cutting line, plant guards, handles, knobs, extension cable and other accessories that are compatible with the product.
 - C. Failure due to lack of routine maintenance.
 - D. Failure as a result of not using the equipment in accordance with the manual and safety instructions
 - E. The adjustment of cables, cutting head, spool and cutting line.

Warranty claims should be submitted before the end of the warranty period, see point 1, but a paid service exists for repairs commissioned after this period. The original warranty period remains applicable to the device even if repairs are carried out or parts are replaced. In such cases, the work performed or parts fitted will not result in an extension of the warranty period, and no new warranty will become active for the work performed or parts fitted.

If you have any problems or questions concerning your garden power tool, please contact our after sales service at 01904 727505 or visit www.spearandjackson-power.com.

This device may be re-conditioned, like for like or upgraded replacement.

EC DECLARATION OF CONFORMITY

We

SUMEC UK Co.,Ltd.
Unit A&B Escrick Business Park
Escrick, York YO19 6FD

Declare that the product

Electric grass trimmer
Factory No: N1F-GT-250/300-C
Model No: GT300
Function: Cut and trim grass
Serial number : EP00001~EX99999

Complies with the following directives:

EMC Directive: 2014/30/EU
Machinery Directive: 2006/42/EC
Noise Directive: 2000/14/EC and 2005/88/EC
RoHS Directive: 2011/65/EU
WEEE Directive 2012/19/EU

Standards conform to:

EN 60335-1:2012+A11:2014
EN 50636-2-91:2014, EN 62233:2008
EN 55014-1:2006/A1:2009/+A2:2011
EN 55014-2:2015
EN 61000-3-2:2014
EN 61000-3-3:2013

We additionally confirm the following in accordance with the 2000/14/EC emissions guideline:

Conformity Assessment Procedure as Per AnnexVI,
Measured sound pressure level L_{pA} : 76.3dB(A),
Measured sound power level L_{wA} : 95.08dB(A), $K=0.38dB(A)$
Guaranteed sound power level L_{wA} : 96dB(A)

Authorized Signatory
Date: 27-02-2017

Signature: M. Hall

Name:
General Manager
Sumec UK Co., Ltd.

