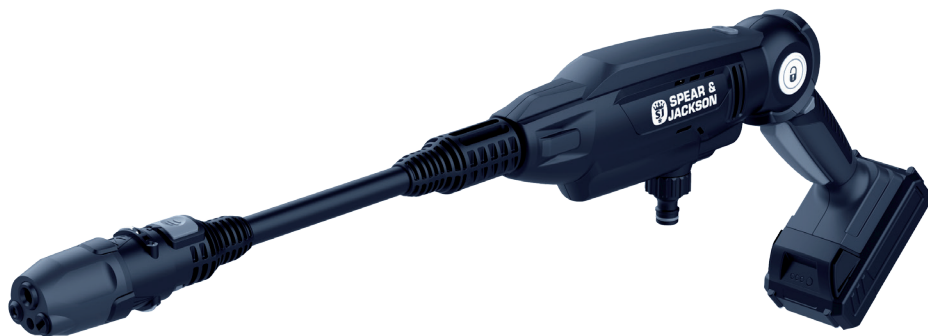

21.6V

CORDLESS Pressure Cleaner

S21CPW

CAUTION Read the instructions before
using the machine

These instructions contain important information that will help you get the best from your pressure Cleaner, ensuring it is assembled correctly and safely. If you need help or have damaged or missing parts, call the Customer Helpline on 0345 605 2067

**AFTER SALES SUPPORT
0345 605 2067**

SAN NO.: 0321/8020/11ZA

SPEAR & JACKSON SINCE 1760

For more than 250 years gardeners have enjoyed high quality performance and great results using Spear & Jackson tools.

Our garden power tools combine continuous innovation and the latest in manufacturing technologies with a proud heritage.

Each product is carefully designed with performance, comfort and durability firmly in mind, which has earned Spear & Jackson an enviable reputation as a maker of tools to trust.

3 YEAR GUARANTEE

As a testament to the quality of our products, we offer a 3 year manufacturers warranty and a comprehensive after sales service.

The warranty covers manufacturing faults, however in the event that the item has been deliberately damaged, used in a commercial environment or disassembled then the warranty will be null and void.

Please retain proof of purchase.

7 DAYS A WEEK TECHNICAL SUPPORT

We want you to get the best out of our products. Our easy-to-read instruction manual guides you with best practice use and maintenance tips. Please call **0345 605 2067** for technical support, we can solve around 80% of questions directly over the phone.

We hope you enjoy your product and we look forward to any feedback, as this allows us to develop even better products in the future.

CONTENTS

Safety Information	04
Description of symbols	04
General safety	05
Personal safety	07
Operating safety	08
Maintenance and storage safety	09
Intended use	09
Box Contents / Parts	10
Assembly	11
Operation	14
Before starting.....	14
Switching on/off.....	14
Adjusting the rotary handle.....	15
Adjusting working pressure.....	15
Using the foam sprayer.....	16
Using the brush.....	16
3 in 1 nozzle.....	16
Maintenance	18
Overview of cleaning	18
Clearing limescale	19
Storing, transport	19
Disposal	19
Technical Data	20
Troubleshooting	21
Guarantee	22

SAFETY INFORMATION

Please read these instructions fully before operating or maintaining your machine

DESCRIPTION OF SYMBOLS

The following warning symbols appear throughout this manual and indicate the appropriate safety measures you should take when operating and maintaining the pressure Cleaner.

WARNING SYMBOLS ON THE MACHINE



Read instruction handbook before operating this machine.



WARNING!

This is a warning symbol. This symbol is used throughout the user guide whenever there is a risk of personal injury. Ensure that these warnings are read and understood at all times.



Wear ear protection



Wear eye protection



Wear safety helmet



Wear protective gloves



Wear proper safety shoes.



Disconnect the battery pack before any repair or maintenance.



Do not expose and operate the tool in rain.



Do not connect the hose to the tap water.



Waste electrical products should not be disposed of with household waste. Please recycle where facilities exist. Check your Local Authority or retailer for recycling advice.



Conforms to all relevant safety standards.

WARNING SYMBOLS ON THE CHARGER



Read instruction handbook before operating this machine.



The charger is for indoor use only.



Double insulation.

SAFETY INFORMATION

Please read these instructions fully before operating or maintaining your machine

WARNING SYMBOLS ON THE BATTERY PACK



Li-ion

Batteries contain Li-ion, waste batteries should be sorted for eco-friendly. Do not dispose of waste batteries as unsorted municipal waste.



Do not dispose of batteries in rivers or immerse in water.



Do not dispose of in fire.



max. 45 °C

Do not subject the battery to strong sunlight over long periods and do not leave it on a heater (max.45 °C).



Do not dispose of batteries. Return exhausted batteries to your local collection or recycling point.

GENERAL SAFETY

WARNING Water jets can be dangerous if subject to misuse. The jet must not be directed at persons, live electrical equipment or the machine itself.

WARNING Do not use the machine within range of persons unless they wear protective clothing.

WARNING Do not direct the jet against yourself or others in order to clean clothes or foot-wear.

WARNING Water cleaners shall not be used by children or untrained personnel.

WARNING Water hoses, fittings and couplings are important for the safety of the machine. Use only hoses, fittings and couplings recommended by the manufacturer.

WARNING To ensure machine safety, use only original spare parts from the manufacturer or approved by the

SAFETY INFORMATION

Please read these instructions fully before operating or maintaining your machine

manufacturer.

WARNING Water that has flowed through backflow preventers is considered to be non-potable.

WARNING Do not use the machine if a supply cord or important parts of the machine are damaged, e.g. safety devices, Water hoses, trigger gun.

WARNING Always switch off the mains disconnecting switch when leaving the machine unattended.

WARNING Pressure may cause parts to rebound .Always wear appropriate personnel protection equipment (PPE) in operation, e.g. safety boots, safety gloves, safety helmets with visors, hearing protection etc., to ensure operator's safety.

WARNING There is a risk of kickback and sudden torque load against the jet spray when the spray gun is opened. Ensure that you are standing firmly and

you are holding the gun securely, otherwise you could injure yourself or other people.

IMPORTANT!

- Keep this instruction manual in a safe place for future reference.
- Read the instructions carefully. Be familiar with the controls and the proper use of the equipment.
- Never use the machine while people, especially children, or pets are nearby. Keep in mind that the operator or user is responsible for accidents or hazards occurring to other people or their property.
- This machine can be used by people with reduced physical, sensory or mental capabilities or lack of experience and knowledge if they have been given supervision or instruction concerning use of the

SAFETY INFORMATION

Please read these instructions fully before operating or maintaining your machine

machine in a safe way and understand the hazards involved.

- Don't use the machine without reading the instruction sheet.
- Machines shall not be used by children. Children should be supervised to ensure that they do not play with the machine

PERSONAL SAFETY



WARNING!

■ RISK OF FATAL INJURY!

Use special care when cleaning tyres. Vehicle tyres/tyre valves may become damaged or burst when handled improperly. First signs of damage include discolourations on the tyre. Damaged vehicle tyres/tyre valves pose a life-threatening risk. Keep the jet at a distance of at least 30cm!

- The appliance is not designed for connecting to tap water. If necessary, please use only with a water backflow preventer or inlet hose-set approved by IEC 61770.
- Risk of injury, do not direct discharge stream at persons.
- Know how to stop the product and bleed pressure quickly, be thoroughly familiar with the controls.

SAFETY INFORMATION

Please read these instructions fully before operating or maintaining your machine

- Stay alert, watch what you are doing.
- Do not operate the product when fatigued or under the influence of alcohol or drugs.
- Keep operating area clear of all persons.
- Do not overreach or stand on unstable support. Keep good footing and balance at all times.
- The operator or user is responsible for accidents or damages to other people or their property.

OPERATING SAFETY

WARNING!

- For safety reasons, pressure hoses, valves and couplings must be used with unit. The new hose-sets supplied with the appliance are to be used. Old hose-sets should not be reused.

OPERATING SAFETY

- Pressure hose fittings and couplings are important for the safety of the appliance. Use only hose fittings and couplings supplied by the manufacturer.

SAFETY INFORMATION

Please read these instructions fully before operating or maintaining your machine

MAINTENANCE AND STORAGE SAFETY



WARNING!

- Retrofitting or making any unauthorised changes to the machine, as well as the use of unapproved parts will invalidate your warranty.
- Do not attempt to repair the equipment yourself. All work not indicated in these instructions is to be carried out only by service stations authorised by us.
- Store the appliance in a dry location and out of reach of children.
- Handle the appliance with care. Keep the equipment clean for safe and more efficient working. Follow the maintenance directions.
- The appliance may be damaged by frost. There is always residual water left inside the pressure cleaner and in the pump. Do not store the machine at temperatures below freezing point

in order to avoid frost damage.

INTENDED USE

This pressure cleaner is designed for domestic use only:

- To clean machines, vehicles, buildings, tools, facades, terraces, garden equipment etc. using a pressure water jet (and detergents if required).
- To use with accessories, replacement parts and detergents approved by Spear & Jackson.
- Observe the instructions provided with these detergents.
- Any use of the machine that deviates from its intended use and is not included in these instructions is considered unauthorised use and relieves the manufacturer from his or her legal liability.

BOX CONTENTS

PARTS

- 1 3 in 1 nozzle
- 2 Main body
- 3 Hose & filter
- 4 Extension lance
- 5 Battery pack
- 6 Charger
- 7 Foam sprayer
- 8 Net bag
- 9 Brush
- 10 Foldable bucket
- 11 Instruction manual

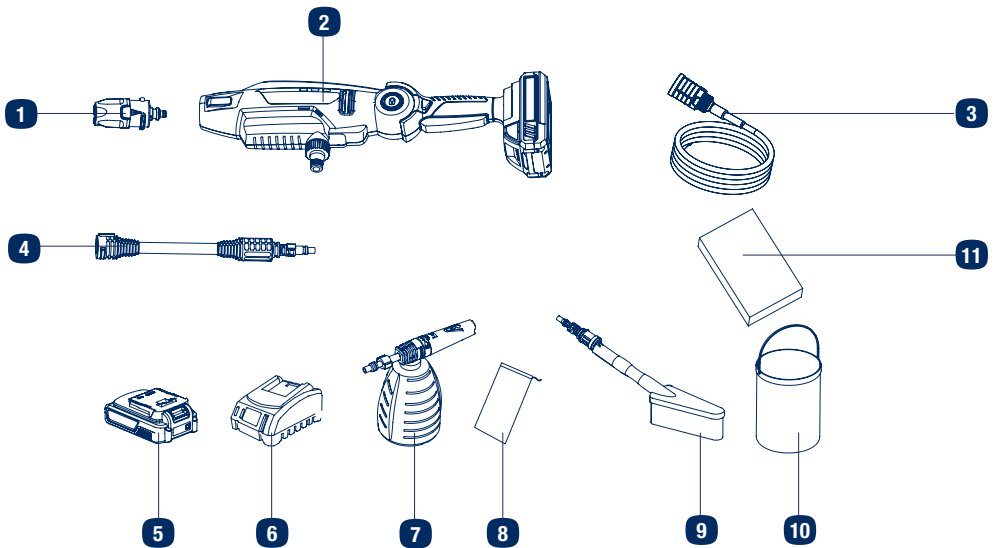

If there are any parts missing, please call the customer helpline on 0345 605 2067

ASSEMBLY

1 Install the extension lance

- i. Press the extension wand into the gun. (You will feel a slight spring resistance)
- ii. Secure the attachment by twisting.
- iii. Make sure that the extension lance button is on the top.

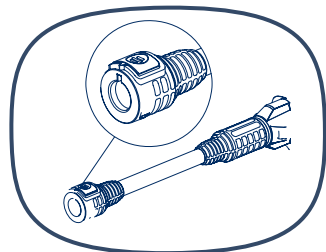
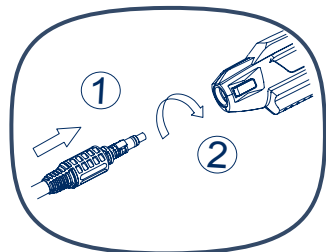

2 Fitting the 3 in 1 nozzle

Press and hold the nozzle lock button on the extension lance, and then assemble the 3in1 nozzle to the lance, make sure that the nozzle is correctly align and fully locked in place.

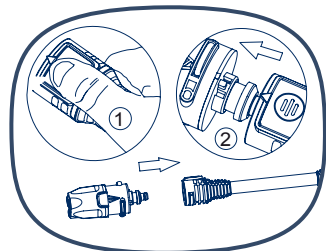

3 Connect the hose

Attach the hose to the main body, make sure it is locked into position fully, you will hear a click noise.

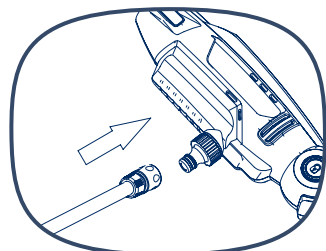

ASSEMBLY

There are 2 water connection options:

- i. Use the self priming function. Put the hose and filter unit into the water source and make sure the filter unit is sunk below the water level.
- ii. Use the garden hose to connect to cleaner. The water supply in keeping with current regulations- ie. a pressure cleaner must never be operated from the drinking water mains supply without a controllable back flow preventer. A suitable back flow preventer in conformity with EN 12729 type BA must be used. Water that has passed through a back flow preventer is classified as undrinkable.

NOTE: A backflow preventer is available from specialist retailers.

NOTE: Water pressure out from the tap should not be higher than 0.6Mpa.

Attach garden hose to water supply and turn water valve to fully on position.

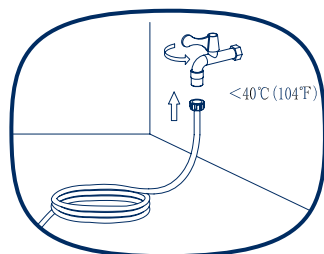
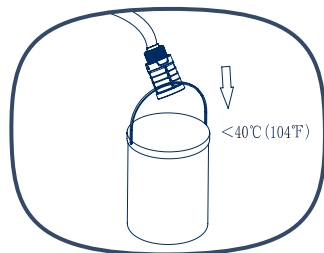

4 Charging the battery pack

NOTE: Remove the battery pack from the charger after it has been fully charged.

NOTE: Battery should be fully charged before first use.

NOTE: Make sure the mains voltage is the same as rating label which is located on the charger.

- i. Connect the charger to a power supply. The RED light will light up.
- ii. To insert the battery pack into the charger, align the raised ribs of the battery pack with the grooves of the charger then push it in.
- iii. Once the battery is fully inserted the charger light will change to flashing green.

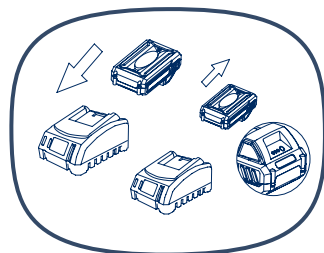

ASSEMBLY

- iv. When the battery is fully charged the green light stops flashing
- v. Once the battery is fully charged, depress the battery release button on two sides of the battery pack and then remove the battery pack.

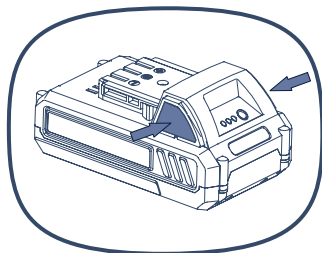

5 Power indicator

This Li-Ion battery pack is equipped with a power indicator which is used to show the battery pack's remaining charge. Press the power indicator button to check battery charge as picture showed.

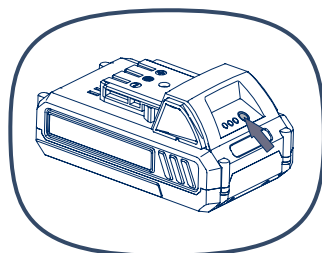

6 To insert the battery pack

- i. Align the groove on the battery pack with the corresponding ribs in the receptacle of the device.
- ii. Insert the battery pack with moderate force until it is locked in to place.

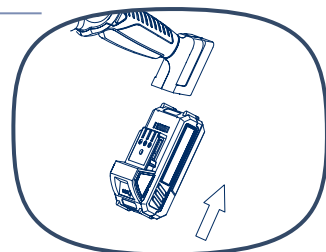

To remove the battery pack from the tool

- i. Press the battery pack release button.
- ii. Remove the battery pack from the tool.

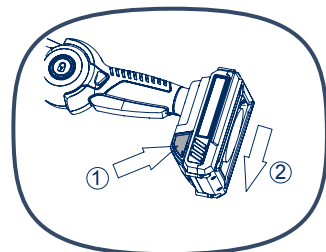

OPERATION



WARNING - Wear suitable clothing, ear and eye protection when working with the equipment.

Before starting

- i. Check the machine for visual defects.
- ii. Check that all parts of the machine have been securely fitted.
- iii. Check if the water connector and the inlet hose are tight.

Switch ON

- i. Depress the safety lock button with your thumb keep it in place. Whilst grip the switch trigger.
- ii. Hold the trigger for at least 15 seconds until there is a steady stream of water.

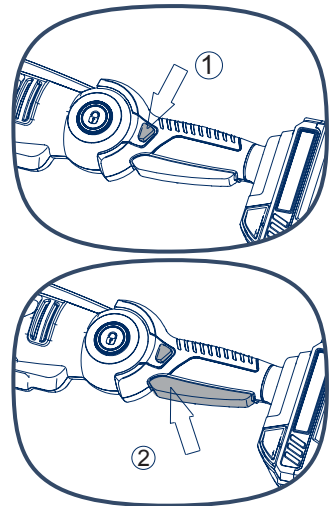

Switch OFF:

- i. Release the switch trigger.

ATTENTION! Risk of machine damage!

Never operate the machine without the water being connected as dry running may damage the pump.
Use a water filter if the inlet water is contaminated.

OPERATION



RISK OF FATAL INJURY!

Use special care when cleaning tyres. Vehicle tyres/ tyre valves may become damaged or burst when handled improperly. First signs of damage include discolourations on the tyre. Damaged vehicle tyres/ tyre valves pose a life-threatening risk. Keep the jet at a distance of at least 30 cm!

The water jet may be dangerous when handled improperly. The jet may not be directed towards living beings (persons, animals), live equipment or the machine itself.

Adjusting rotary handle

This device is equipped with the handle that can be adjusted. Press the rotary handle button and keep it in place, adjust handle as in the picture shown.

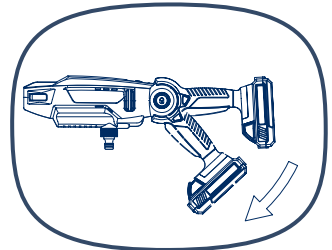
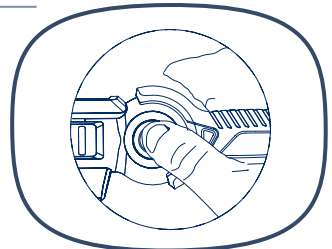

Adjusting working pressure

Press the Eco/High pressure switch button to switch Eco/ HIGH working pressure.

Eco model: Green light on.

High working pressure: Light off.

NOTE: When operate this cleaner under ECO mode, the working time will last around 20 to 25 minutes.

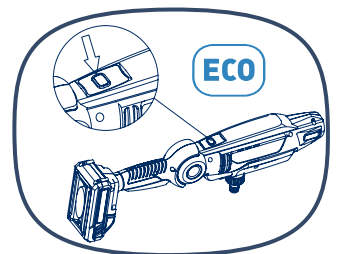

OPERATION

Using the foam sprayer

1. Fill the detergent into the bottle (detergent mixture level to be between 30-50%).
2. Install the foam sprayer on to the device.

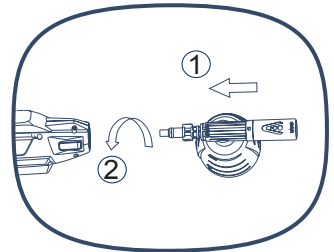
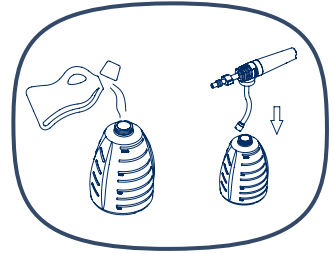

Using the brush

Install the brush onto the device like picture shown.

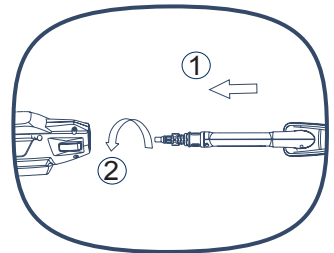

3 in 1 nozzle (Fig. R)

3 in 1 nozzle can be adjusted to 3 different nozzles by rotating the head.

OPERATION

This nozzle can be adjusted to 3 different settings by rotating the head.

Whilst holding the lance rotate the nozzle to your selected position making sure the nozzle is align with the lance arrow.

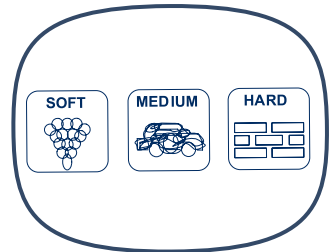
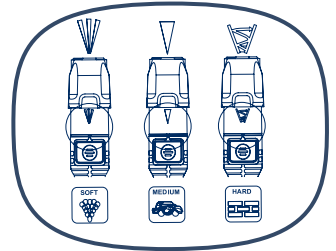
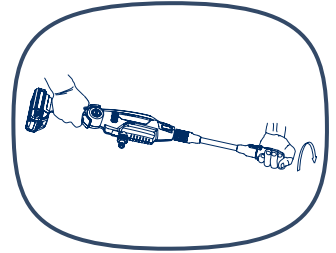

MAINTENANCE

Overview of cleaning

- After every use, wipe the machine with a slightly damp cloth. Do not clean the machine by using a pressure cleaner jet.
- Clean the high-pressure jet nozzle.

The pressure cleaner is equipped with a water filter in inlet adapter to protect the pump. If the filter is not kept clean, the water flow to the machine will be restricted and the pump may be damaged.

To clean water filter, remove inlet adapter and get the filter out.

- Rinse filter until it is free of debris and blockage.
- Replace the filter and inlet adapter.



WARNING - If Salty water has been used, make sure the cleaner has been fully flushed out for 5 minutes using clean warm water.

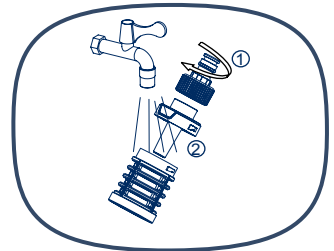
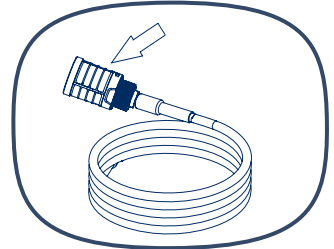
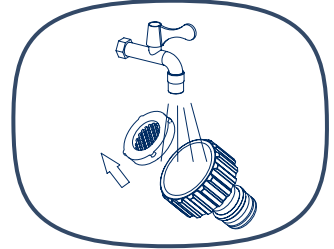
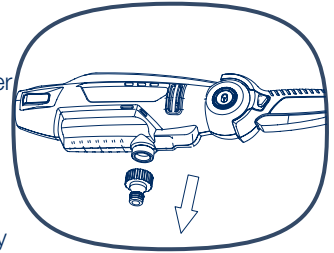

MAINTENANCE

Storing

Store the machine where it is dry and well ventilated.

When placing the machine out of service for an extended period of time, remove the cleaning agent and drain all the water left in the hoses.

Transport

If shipping, use the original packaging wherever possible.

Disposal

Disposing of the machine

Machines which are labelled with the this symbol  must not be disposed in household rubbish. You must dispose such old electrical and electronic appliances separately.

Please check with your local authority about the possibilities for correct disposal. You will thus help to avoid that damaging into the environment.

Disposing of the packaging

The packaging consists of cardboard and correspondingly marked sheets that can be recycled. Make these materials available for recycling.

TECHNICAL DATA

Model	S21CPW
Nominal voltage of product with battery	21.6V d.c. / 2.5 Ah
Water inlet pressure	< 0.6 MPa
Working pressure	Eco: 13 Bar High: 22 Bar
Working flow rate	2.67 l/min
Weight	1.8 kg
Battery pack Model	B0P-SP01-2125ZF
Battery capacity	2.5 Ah
Battery charging time Max.	75 min
Battery charger Model	ZDBC2600-2200
Input	220-240 V AC, 50/60 Hz
Output	DC 26 V, 2.2 A
Protection class	II

TROUBLESHOOTING

Suspected malfunctions are often due to causes that the user can fix themselves. Therefore, check the product using this section. In most cases the problem can be solved quickly.



WARNING - Only perform the steps described within these instructions! All further inspection, maintenance and repair work must be performed by an authorised service centre or a similarly qualified specialist if you cannot solve the problem yourself!

Gloves and appropriate protective clothing must be worn when performing these instructions.

Fault/ malfunction	Cause	Remedy
Machine does not turn ON	Battery pack discharged?	Fully charge the battery pack
	Battery pack is not connected correctly onto the cleaner.	Install the battery pack once again.
	Safety lock off button has not been depressed.	Check start procedure 1. depress lock off 2. depress switch lever
	m/c PCB activated.	Restart the device
	Pump frozen.	Check and allow the machine to thaw
Machine water pressure too low	Hose damaged OR leaks in the connections.	Change the hose - check the hose for leaks and repair - securely tighten the screw connection
	Filter blocked.	Clean filter on the machine and hose on the hose
	Hose is trapped or kinked.	straighten out the hose
	Inadequate water supply.	check water supply levels
	The machine /water source height is too large.	Lower the machine - maximum working height @1.5M- 5ft
Water leaks	O-ring split/broken	replace the accessory or change the O-ring
	Attachment are not installed correctly	remove & re-install the attachment correctly
	Accessories broken	replace accessories
Detergent cannot spray out	Speed setting on Low	Select speed setting High
	Deposits or restrictions in the detergent system	Flush with clean water and remove all debris

GUARANTEE

If your device develops a fault, please don't hesitate to contact our customer service department on 0345 605 2067, the majority of issues can be solved directly over the phone.

1. These warranty terms cover additional warranty rights and do not affect your statutory warranty rights. All our products are covered by a 3 year manufacturer warranty
2. Claims must be accompanied by Proof of Purchase. This must be in the form of a sales receipt or Bank statement and must show that the product has been purchased within the warranty period as described under point 1, from the retailer that it was originally bought from. Please keep your receipt safe or staple it to the back of this manual for future reference.
3. Our warranty covers problems caused by material or manufacturing defects, and will result in the repair of these defects or replacement of the device with a like for like or similar article.
4. Our devices have not been designed for commercial, trade or industrial applications, any signs of use of the equipment in these application or equivalent activities, invalidates the warranty.
5. The following are also excluded from our warranty:
 - A. Faults due to accidents, customer misuse or unauthorised repairs
 - B. Consumable parts such as detergent bottle, patio cleaner, jet lance, fixed brush and nozzle pin, and other accessories that are compatible with the product.
 - C. Failure due to lack of routine maintenance.
 - D. Failure as a result of not using the equipment in accordance with the manual and safety instructions
 - E. The adjustment of cables, pumps, or lances.

Warranty claims should be submitted before the end of the warranty period, see point 1, but a paid service exists for repairs commissioned after this period. The original warranty period remains applicable to the device even if repairs are carried out or parts are replaced.

In such cases, the work performed or parts fitted will not result in an extension of the warranty period, and no new warranty will become active for the work performed or parts fitted.

5. Please keep your sales receipt in a safe place. If it is covered by our guarantee your device will either be repaired under the terms of guarantee or we will send you a replacement device.

This device may be re-conditioned, like for like or upgraded replacement.

If you have any problems or questions concerning your garden power tool, please contact our after sales service at 0345 605 2067.