



**SPEAR &  
JACKSON**

# ORIGINAL INSTRUCTION MANUAL

**32cm 400W**

# Electric Cylinder Lawnmower

**SCM32C**



**Important - Please read these instructions  
fully before starting assembly**

These instructions contain important information that will help you get the best from your mower, ensuring it is assembled correctly and safely. If you need help or have damaged or missing parts, call the Customer Helpline on 0345 605 2067

**AFTER SALES SUPPORT  
0345 605 2067**

# SPEAR & JACKSON SINCE 1760

For more than 250 years gardeners have enjoyed high quality performance and great results using Spear & Jackson tools.

Our garden power tools combine continuous innovation and the latest in manufacturing technologies with a proud heritage.

Each product is carefully designed with performance, comfort and durability firmly in mind, which has earned Spear & Jackson an enviable reputation as a maker of tools to trust.

## 3 YEARS GUARANTEE

As a testament to the quality of our products, we offer a 3 year manufacturers warranty and a comprehensive after sales service.

The warranty covers manufacturing faults, however in the event that the item has been deliberately damaged, used in a commercial environment or disassembled then the warranty will be null and void.

Please retain proof of purchase.

## 7 DAYS A WEEK TECHNICAL SUPPORT

We want you to get the best out of your products. Our easy-to-read instruction manual guides you with best practice use and maintenance tips. Please call **0345 605 2067** for technical support, we can solve around 80% of questions directly over the phone.

We hope you enjoy your product and we look forward to any feedback, as this allows us to develop even better products for the future.

# CONTENTS

<b>Safety Information.....</b>	<b>04</b>
Description of symbols.....	04
General safety.....	05
Personal safety.....	06
Operating safety.....	07
Maintenance and storage safety.....	10
Intended use.....	11
<b>Box Content / Parts.....</b>	<b>12</b>
<b>Assemble.....</b>	<b>13</b>
Unpacking.....	13
Assemble the lower handles.....	13
Assemble the middle and upper handles.....	14
Securing the power cord with cable clip.....	15
Fitting the grass box .....	15
Connection to the power supply.....	16
<b>Operate.....</b>	<b>17</b>
General operation.....	17
Setting cutting height.....	17
Switching on.....	18
Switching off.....	18
Operating the cylinder Mower.....	19
Empty the grass bag.....	19
Adjusting the blade clearance.....	20
<b>Maintenance .....</b>	<b>21</b>
<b>Technical Data.....</b>	<b>25</b>
<b>Troubleshooting.....</b>	<b>26</b>
<b>Warranty.....</b>	<b>28</b>

# SAFETY INFORMATION

Please read these instructions fully before operating or maintaining your machine.

## DESCRIPTION OF SYMBOLS

The following warning symbols appear throughout this manual and indicate the appropriate safety measures you should take when operating and maintaining your lawnmower.



Read instruction handbook before operating this machine.



This is a warning symbol. This symbol is used throughout the user guide whenever there is a risk of personal injury. Ensure that these warnings are read and understood at all times.



Wear eye protection.  
Wear ear protection.



Keep bystanders away.



WARNING! Remove plug from the mains immediately if the cable is damaged or cut.



SWITCH OFF! Remove plug from mains before cleaning or maintenance.



Do not expose and operate the tool in rain.



Double insulation.



Danger from damaged mains cable. Keep mains cables away from blades!



Danger of injury from rotating parts. The blades will continue to rotate after the tool has been switched off. Wait for them to stop moving.



Guaranteed sound power level value in 96 dB.



Electrical Tool Disposal! In accordance with European Directive 2002/96/EC on waste electrical and electronic equipment and its implementation in national law. Electric tools are collected separately and recycled environmentally. Take advantage of the collection facilities. Ask your local council for the collection systems. If electrical appliances are disposed incorrectly the environment can be poisoned as the hazardous substances enter into the groundwater and entering the food chain, or flora and fauna.

# SAFETY INFORMATION

Please read these instructions fully before operating or maintaining your machine

## GENERAL SAFETY

### ! IMPORTANT!

Read all instructions. Failure to follow all instructions listed below may result in electric shock, fire and/or serious injury. The term “power tool” in all warnings listed below refers to your mains operated power tool.

- Keep this operating and maintenance manual in a safe place for future reference.
- Read the instructions carefully. Be familiar with the controls and the proper use of the equipment.
- Never allow children or people unfamiliar with these instructions to use the rear roller cylinder mower. Local regulations can restrict the age of the operator.
- Never mow while people, especially children, or pets are nearby. Keep in mind that the operator or user is responsible for accidents or hazards occurring to other people or their property.
- This appliance is not intended for use by persons (including children) with reduced physical, sensory or mental capabilities, or lack of experience and knowledge, unless they have been given supervision or instruction concerning use of the appliance by a person responsible for their safety.
- Keep all bystanders, children, and pets at least 50 feet away. The operator or user is responsible for accidents or hazards occurring to other people or the property.

## SAFETY INFORMATION

Please read these instructions fully before operating or maintaining your machine

### PERSONAL SAFETY

- Use personal protective equipment (PPE). Always wear eye protection. Protective equipment such as dust mask, non-slip safety shoes, hard hat, or hearing protection used for appropriate conditions will reduce personal injuries.
- Dress appropriately. Do not wear loose clothing or jewellery, as these can be caught in moving parts. Preferably wear non-slip footwear when working outdoors. Wear protective hair covering to keep long hair out of the way.
- Stay alert, watch what you are doing and use common sense when operating a power tool. Do not use a power tool while you are tired or under the influence of drugs, alcohol or medication. A lapse of concentration while operating power tools may result in serious personal injury.
- Prevent unintentional starting. Ensure the switch is in the off-position before connecting to power source, picking up or carrying the tool. Carrying power tools with your finger on the switch or energising power tools that have the switch on invites accidents.
- Keep all parts of the body away from the cutting blades. Make sure the switch is off when clearing jammed material. A moment of inattention while operating the cylinder mower may result in serious personal injury.
- Do not overreach. Keep proper footing and balance at all times. This enables better control of the power tool in unexpected situations.
- Do not touch the rotating blades until they are stopped.

## SAFETY INFORMATION

Please read these instructions fully before operating or maintaining your machine

### OPERATION SAFETY

- Be certain the parts are fully tightened before operating the tool. Check periodically for tightness during use to avoid serious injury.
- Risk of injury. Do not touch or try to stop the blades when they are moving.
- Disconnect the plug. Disconnect plug from the tool when not in use or when servicing or cleaning.
- Check for damaged parts. Before further use, carefully check the tool for damage. Check for alignment of moving parts, binding of moving parts, breakage of parts, mountings and any other condition that may affect its operation. Do not use the tool if any parts are damaged or defective.
- Have any damaged or defective parts repaired or replaced by an authorised service agent. Never attempt any repairs yourself.
- Grip the tool securely. Always hold the tool securely in both hands while working with it.
- Keep handle dry, clean and free from oil and grease. Slippery handles do not allow for safe handling and control of the tool in unexpected situations.
- Keep cable away from cutting area. During operation the cable may be hidden in shrubs and can be accidentally cut by the blade.
- Do not overload the tool. Only work in the performance range stated. Do not use tools that do not have sufficient power for heavy jobs. Do not use the tool for any use other than that intended by the manufacturer.

## SAFETY INFORMATION

Please read these instructions fully before operating or maintaining your machine

- If there is any danger of slipping on sloped ground, have a second person secure the tool with a rod or cable. The second person should stand up the slope at a safe distance from the tool.
- Avoid damage to the tool. Do not apply extra weight and do not drag the tool over hard surfaces such as tiles or steps.
- Do not use the tool on excessively steep slopes. Make sure that you are standing firmly when using the tool, especially on slopes. If working on a slope, work along the slope, not upwards or downwards. Be particularly careful when changing direction on the slope.
- Do not use the power tool if the switch does not turn it on and off. Any power tool that cannot be controlled with the switch is dangerous and must be repaired.
- Disconnect the plug from the power source before making any adjustments, changing or storing power tools. Such preventive safety measures reduce the risk of starting the power tool accidentally.
- The use of a residual current device (R.C.D) with a tripping current of not more than 30mA is recommended.
- Use appropriate tool. This device is only intended for mowing the lawn in private house and hobby gardens. Do not force small tools or attachments to do the job of a heavy duty tool.
- Keep work areas clean. Check the terrain on which the tool will be used, and remove stones, sticks, wires or other foreign objects that may be caught up and spun off.

## SAFETY INFORMATION

Please read these instructions fully before operating or maintaining your machine

- Consider work area environment. Do not expose your tool to high humidity or rain. Do not use your tool in damp and wet conditions. Keep the work area well lit.
- Do not operate power tools in explosive atmospheres, such as in the presence of flammable liquids, gases or dust. Power tools create sparks which may ignite the dust or fumes.
- Power tool plugs must match the outlet. Never modify the plug in any way. Do not use any adapter plugs with earthed (grounded) power tools. Unmodified plugs and matching outlets will reduce risk of electric shock.
- Avoid body contact with earthed or grounded surfaces, such as pipes, radiators. There is an increased risk of electric shock if your body is earthed or grounded.
- Do not expose power tools to rain or wet conditions. Water entering a power tool will increase the risk of electric shock.
- Do not abuse the cord. Never use the cord for carrying, pulling or unplugging the power tool.
- Keep cord away from heat, oil, sharp edges or moving parts. Damaged or entangled cords increase the risk of electric shock.
- When operating a power tool outdoors, use an extension cord suitable for outdoor use. Use of a cord suitable for outdoor use reduces the risk of electric shock.

## SAFETY INFORMATION

Please read these instructions fully before operating or maintaining your machine

### MAINTENANCE AND STORAGE

- Maintain tools with care. Keep tools clean and in good condition for better and safer performance. Follow the instructions for maintenance and changing accessories. Keep handles and switches dry, clean and free from oil and grease.
- Be careful in handling the tool. Keep the cutting blades sharp and clean to improve its working safety and effectiveness.
- Store idle power tools out of the reach of children and do not allow people unfamiliar with the power tool or these instructions to operate the power tool. Power tools are dangerous in the hands of untrained users.
- Have your tool repaired by an authorised service agent. This tool is manufactured in accordance with the relevant safety regulations.

To avoid danger, electrical appliances must only be repaired by qualified technicians. If you require support or in need of spares or repair, please contact the Garden Service Centre at 0345 605 2067.

## SAFETY INFORMATION

Please read these instructions fully before operating or maintaining your machine

### INTENDED USE

- This lawnmower is designed for domestic use only:
- This electric lawnmower is intended for mowing lawns in domestic and hobby gardens.
  - This product is not to be used in wet weather conditions and may not be used to mow wet or unusually high grass, e. g. pasture grass or for shredding leaves.
  - This product is intended for private domestic use only, not for any commercial trade use. It must not be used for any purposes other than those described. Any use of the machine that deviates from its intended use and is not included in these.

# BOX CONTENTS

## PARTS

- |                             |   |
|-----------------------------|---|
| <b>1</b> Switch box         | <b>9</b> Motor housing                    |
| <b>2</b> Power cable        | <b>10</b> Height adjustment handle        |
| <b>3</b> Locking knob x4pcs | <b>11</b> Rear roller                     |
| <b>4</b> Cable hooks        | <b>12</b> Blade                           |
| <b>5</b> Upper handle       | <b>13</b> Front roller                    |
| <b>6</b> Middle handle      | <b>14</b> Lower handle fixing knob x 2pcs |
| <b>7</b> Lower handle       | <b>15</b> Cable clip x 2pcs               |
| <b>8</b> Carry handle       | <b>16</b> Cable retainer                  |

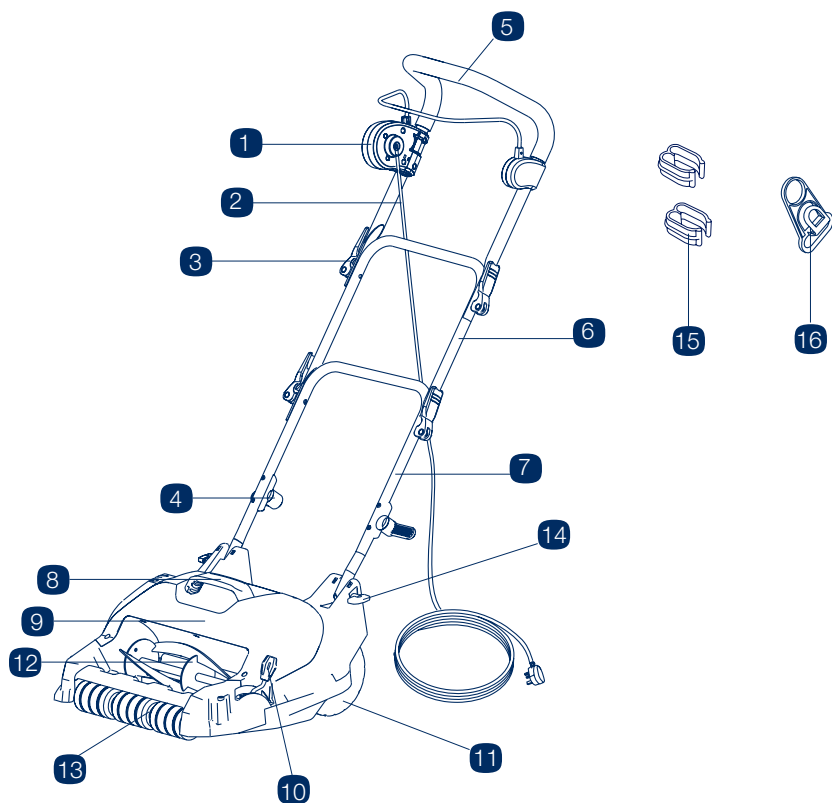

If there are any parts missing, please call the customer helpline on **0345 605 2067**

# ASSEMBLE

## 1 Unpacking

- i. Unpack all parts and lay them on a flat, stable surface.
- ii. Remove all packing materials and shipping devices if applicable.
- iii. Make sure the delivery contents are complete and free of any damage. If you find that parts are missing or show damage do not use the product but contact the aftersales service within 28 days of purchase. Using an incomplete or damaged product represents a hazard to people and property.
- iv. Ensure that you have all the accessories and tools needed for assembly and operation. This also includes suitable personal protective equipment.

## 2 Assemble the lower handles

Locate the lower handle to the slot on deck, and tighten the lower handle fixing knobs(14) on both sides.

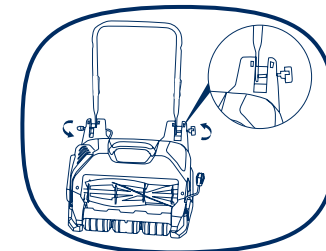

**NOTE!** Make sure that the cable hooks are at the back side of the machine.

If they are at the front of handle, you can't fully fold this product for easy storage.

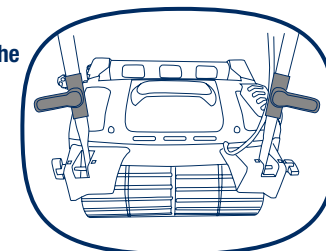

## ASSEMBLE

### 3 Assemble the middle and upper handles

- i. Slide the cord retainer onto the middle handle, sliding it around to the top of the handle so it does not fall off during the following assembly steps.

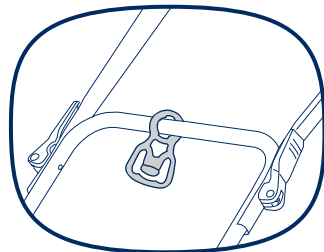

- ii. Slide the middle handle into the profiled area of the lower handle frame. Make sure that the holes of both sides of the upper handle are directly aligned with the holes of the frame.

- iii. Secure the upper handle to the middle handle frame with the locking knob and bolts provided.

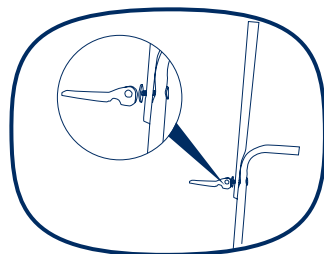

- iv. Repeat the above process on the middle and lower handle.

**NOTE!** Make sure that the switch box is on the same side as the cable from the deck and that they are not twisted.

## ASSEMBLE

### 4 Securing the power cord with cable clip

- Secure the power cable to the frame using the cable clips. Use one clip on the middle handle frame and the second on the lower handle frame.

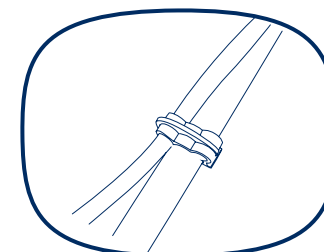

### 5 Fitting the grass box

- i. Attach the grass bag to the frame by fixing all plastic hooks.
- ii. The grass bag front plate (A) is at the original position, need assemble.

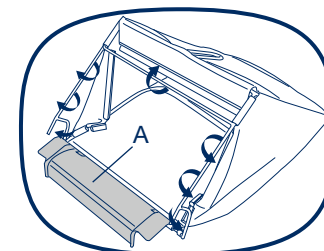

- iii. Lift & rotate the front plate until the locking tab clips (B) over the frame.

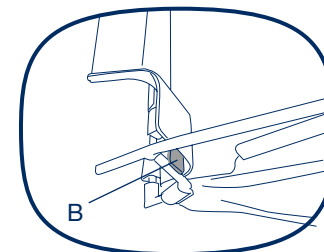
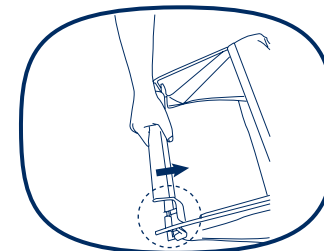

## ASSEMBLE

- iv When assembling the grass bag onto the machine, lift the front plate(A) cross strap and locate the 2 pins into the slot holes on the deck.

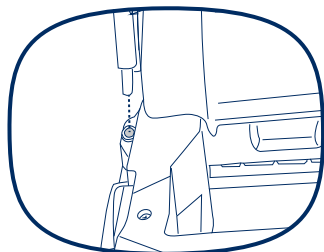
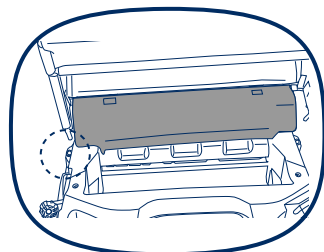

**NOTE! Make sure the front plate(A) is on the bar above front roller.**

### 6 Connection to the power supply

- i. Double the extension cord, about a foot from the end. Hook the loop over the cord strain.

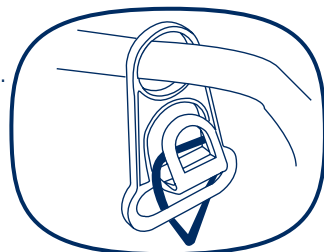

- ii. Connect the plug to the main socket.

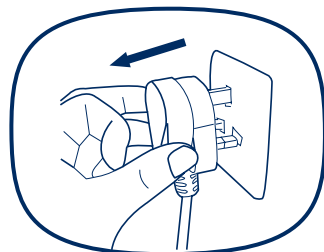

## OPERATE

### General operation

- Check the product, its power cord and plug, as well as accessories for damage before each use. Do not use the product if it is damaged or shows wear.
- Double check that accessories or cutting device are properly fixed.
- Always hold the product by its handles. Keep the handles dry to ensure safe support.
- Ensure that the air vents are always unobstructed and clear. Clean them if necessary with a soft brush. Blocked air vents may lead to overheating and damage the product.
- Switch the product off immediately if you are disturbed while working by other people entering the working area. Always let the product come to complete stop.
- Do not overwork yourself. Take regular breaks to ensure you can concentrate on the work and have full control over the product.

**NOTE! Only operate the product at reasonable hours - not early in the morning, late at night when people might be disturbed. Inform yourself about local restrictions.**

### Setting cutting height

This Cylinder mower can be set to 3 positions of cutting height. Position 3 is the lowest cutting height.

- Pull the lever outwards from the machine and then select your required cutting height position 1-2-3.
- Release the lever and then make sure that it is fully secured into the selected cutting position.

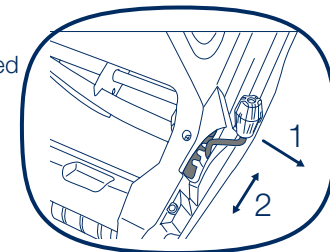

**NOTE! Always ensure the lever clicks back in its slot.**

# OPERATE

Cutting position	Cutting height
1	18 mm
2	28 mm
3	38 mm

## Switching on

- i. Press the button (1).
- ii. Pull the switch bar (2) towards the handle and hold in position.

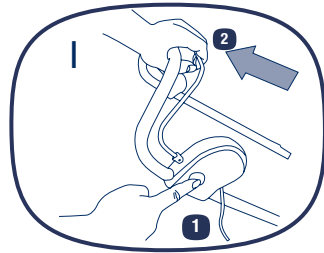

## Switching off

Release the switch bar.

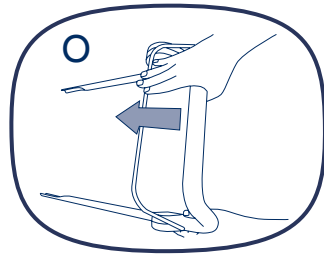

# OPERATE

## Operating the Cylinder Mower



### WARNING!

- Always keep a firm grip on the tool with both hands and watch your feet. The blades may cause an accident. Be careful while moving backwards –danger of tripping!

To avoid damage to the tool:

- Never lift or drag the tool with the motor running.
- When mowing, do not allow the motor to labour particularly in heavy conditions.
- When the motor labours, the speed of the motor drops and you will hear a change in the motor sound, you should stop the mowing immediately and release the switch lever and raise the height of cut.

- i. Place the cylinder mower on the edge of the lawn.
- ii. Always work away from the mains socket. Make sure that the cable is kept well away from the working area.

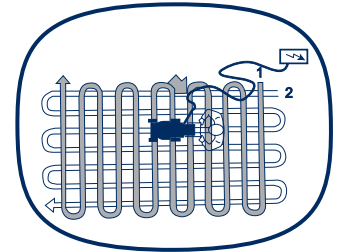

**NOTE! The blades may require adjustment, particularly before first use— see Adjusting the blades.**

## Empty the grass bag

- i. Take off the grass bag and empty it.
- ii. Re-fit the grass bag onto machine.

# OPERATE

## Adjusting the blade clearance



### ATTENTION!

The blade is adjusted well by manufacture, only adjust it if the mower can't cut well.



### WARNING!

Never adjust the blade while the machine is plugged into the main power source.

Cylinder mower blades act like a pair of shears and should be adjusted if the grass is not cut cleanly and evenly.

- i. Turn the mower upside down and using a screwdriver, turn each adjustment screw as shown above, clockwise a little at a time.
- ii. Wearing gloves, carefully rotate the cutting cylinder (C) by hand to ensure it very lightly brushes across the whole width of the bottom blade. If the blades are too difficult to turn, slightly loosen each adjustment screw (D).
- iii. While the blade reel is turning, insert a sheet of paper (thickness around 0.12mm) between the blade reel (C) and the cutting bar (E). The paper should shear evenly along the entire length of the cutter bar, as if being cut by scissors. If the paper doesn't shear, slightly tighten each adjustment screw (D) and repeat the test.
- iv. Turn the mower back over, plug it and try it. It should now be giving a clean and even cut. If not, unplug and re-adjust screws.

From time to time during use, it is advisable to carry out the above procedure to ensure that your cylinder mower is always cutting at its best.

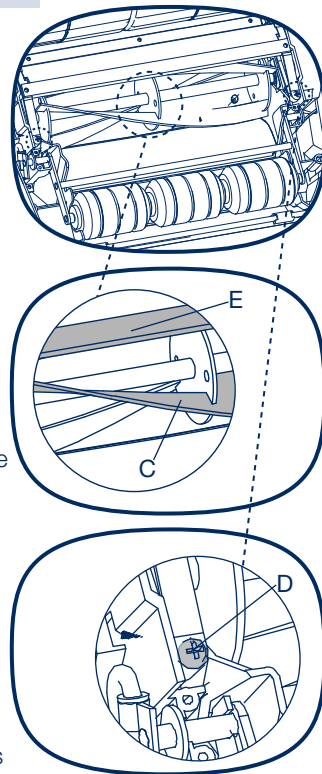

# MAINTENANCE



### WARNING!

Always switch the product off, disconnect it from the power supply and let the product cool down before performing inspection, maintenance and cleaning work!



- i. Clean the product with a slightly damp cloth and pH-neutral soap. Use a brush for areas that are hard to reach.
- ii. Clean all of the rollers front and rear from grass/dirt debris. In particular clean the air vents with a cloth and brush.
- iii. Remove stubborn dirt with high pressure air (max. 3 bar).
- iv. Check for worn or damaged parts. Replace worn parts as necessary or contact an authorized service centre for repair before using the product again.
- v. Check for obvious defects such as loose, dislodged or damaged cutting device, loose fixings and worn or damaged components.
- vi. Check that covers are undamaged and correctly fitted. Carry out necessary maintenance or repairs before using the product.
- vii. Regularly apply lubricant to mower's cutting surface, cutting reel axle shaft and wheels.

# MAINTENANCE

## Storage

- i. Clean the product as described above.
- ii. Store the product and its accessories in a dark, dry, frost-free, well-ventilated place.
- iii. Always store the product in an upright or horizontal position in a place that is inaccessible to children. The ideal storage temperature is between 10°C and 30°C.
- iv. We recommend using the original package for storage or covering the product with a suitable cloth or enclosure to protect it against dust.

## Cable tidy system

After use, wrap your extension cable around the cable hooks and secure the plug in place.

To release the extension cable for machine use, just rotate the cable hook.

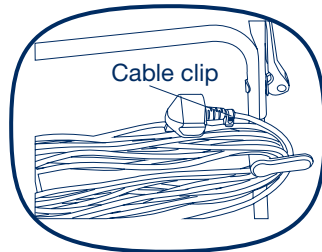
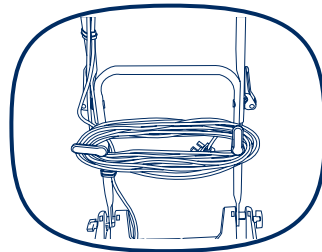

# MAINTENANCE

## Handle positions storage

- i. Push the lower handle to the right and then rotate forward, make sure the lower handle is out of the block position.

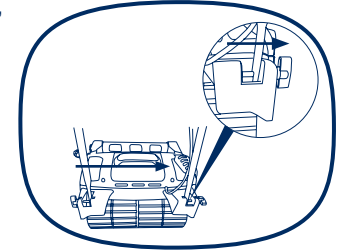

- ii. Release the locking knobs and fold the handle down.

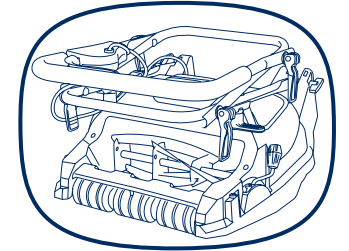

## Transportation

- i. Switch the product off and disconnect it from power supply before transporting it ~~anywhere~~.
- ii. Always carry the product by the central carry handle.
- iii. Protect the product from any heavy impact or strong vibrations which may occur during transportation in vehicles.
- iv. Secure the product to prevent it from slipping or falling over.

**NOTE! Always carry the product by the central carry handle.**

# MAINTENANCE

## Repair

This product does not contain any parts that can be repaired by the consumer. Contact an authorised service centre or a similarly qualified person to have it checked and repaired.

## Recycling and disposal

- The product comes in a package that protects it against damage during shipping. Keep the packaging until you are sure that all parts have been delivered and the product is functioning properly. Recycle the packaging afterwards.
- Old products are potentially recyclable and do not, therefore, belong in your household rubbish. You are requested to assist us and our contribution to saving resources and protecting the environment by handing in this product at an equipped collection centre (if there is one available).



# TECHNICAL DATA

Model	SCM32C
Motor Voltage	230-240V ~/50Hz
Power Input	400 W
No-load speed	3700 /min
Cutting width	32 cm
Height of cut	18mm/28mm/38mm
Net Weight	12 kg
Measured sound pressure level	74 dB(A), k=4 dB(A)
Measured sound power level	94 dB(A), k=4 dB(A)
Guaranteed sound power level	96 dB(A)
Vibration (m/s <sup>2</sup> )	2.323 m/s <sup>2</sup> K=1.5 m/s <sup>2</sup>

PART NUMBER	ACCESSORIES
1455901	Grass bag
1413010	Locking knob
1413216	Locking bolt

The sound values have been determined according to noise test code given in EN 60335-2-77, using the basic standards EN ISO 11201 and EN ISO 3744.

The sound intensity level for the operator may exceed 80 dB(A) and ear protection measures are necessary.

The declared vibration value has been measured in accordance with a standard test method (according to EN 60335-2-77) and may be used for comparing one product with another. The declared vibration value may also be used in a preliminary assessment of exposure.

**WARNING!** Depending on the actual use of the product the vibration values can differ from the declared total! Adopt proper measures to protect yourself against vibration exposures! Take the whole work process including times the product is running under no load or switched off into consideration!

Proper measures include among others regular maintenance and care of the product and cutting attachments, keeping hands warm, periodical breaks and proper planning of work processes!

## TROUBLESHOOTING

Suspected malfunctions are often due to causes that the user can fix themselves. Therefore, check the product using this section. In most cases the problem can be solved quickly.



**WARNING!** Only perform the steps described within these instructions! All further inspection, maintenance and repair work must be performed by an authorised service centre or a similarly qualified specialist if you cannot solve the problem yourself!  
Gloves and appropriate protective clothing must be worn when performing these instructions.

Fault	Possible Cause	Solution
Product does not start	<ol style="list-style-type: none"> <li>1. Not connected to power supply.</li> <li>2. Power connection is loose</li> <li>3. Other electrical defect to the product.</li> </ol>	<ol style="list-style-type: none"> <li>1. Connect to power supply</li> <li>2. Connect the power supply and tool well</li> <li>3. Check by a specialist electrician</li> </ol>
Product does not reach full power	<ol style="list-style-type: none"> <li>1. Extension cord not suitable for operation with this product</li> <li>2. Power source (e.g. generator) has too low voltage</li> <li>3. Machines internal wiring damaged</li> </ol>	<ol style="list-style-type: none"> <li>1. Use a proper extension cord</li> <li>2. Connect to another power source</li> <li>3. Contact the customer helpline</li> </ol>
Machine not cutting	<ol style="list-style-type: none"> <li>1. Height of cut too low</li> <li>2. Blades off cut</li> </ol>	<ol style="list-style-type: none"> <li>1. Increase height of cut (See -- Adjusting the cutting height)</li> <li>2. Blades require adjustment (See— Adjusting the blades clearance)</li> </ol>
Machine leaves ragged finish	Cutting blades blunt	Blade require adjustment (See— Adjusting the blades clearance)
Cutting blades not rotating	<ol style="list-style-type: none"> <li>1. Cutting blades obstructed</li> <li>2. Belt is slipping or is damaged</li> </ol>	<ol style="list-style-type: none"> <li>1. Clear obstruction</li> <li>2. Contact customer helpline</li> </ol>

## TROUBLESHOOTING

Fault	Possible Cause	Solution
Excessive vibration/ noise	<ol style="list-style-type: none"> <li>1. Cutting blades damaged</li> <li>2. Cutting blades not adjusted evenly</li> </ol>	<ol style="list-style-type: none"> <li>1. Contact customer <a href="#">helpline</a></li> <li>2. Blades require adjustment (See— Adjusting the blades clearance)</li> </ol>
Rollers do not rotate	Roller is blocked by debris	Clean all roller slots

# WARRANTY

If your device develops a fault, please don't hesitate to contact our customer service department on 0345 605 2067, the majority of problems can be solved directly on the phone.

1. These warranty terms cover additional warranty rights and do not affect your statutory warranty rights. All our products are covered by a 3 year manufacturer warranty.
2. Claims must be accompanied by proof of purchase. This must be in the form of a Sales receipt or bank statement and must show that the product has been purchased within the warranty period as described under point 1, from the retailer that it was originally bought from. Please keep your receipt safe or staple it to the back of this manual for future reference.
3. Our warranty covers problems caused by material or manufacturing defects, and will result in the repair of these defects or replacement of the device with a like for like or similar article.
4. Our devices have not been designed for commercial, trade or industrial applications, any signs of use of the equipment in these application or equivalent activities, invalidates the warranty.
5. The following are also excluded from our warranty:
  - A. Faults due to accidents, customer misuse or unauthorized repairs
  - B. Consumable Parts such as blades, quick release locks, extension cables, wheels, grass bags and other accessories that are compatible with the product.
  - C. Failure due to lack of routine maintenance.
  - D. Failure as a result of not using the equipment in accordance with the manual and safety instructions
  - E. The adjustment of cables, drives belts or or switch box.

Warranty claims should be submitted before the end of the warranty period, see point 1, but a paid service exists for repairs commissioned after this period. The original warranty period remains applicable to the device even if repairs are carried out or parts are replaced.

In such cases, the work performed or parts fitted will not result in an extension of the warranty period, and no new warranty will become active for the work performed or parts fitted.

If you have any problems or questions concerning your garden power tool, please contact our after sales service at 0345 605 2067.