



User Manual

Spend a little Live a lot

WITH
**QUICK
START
GUIDE**



46cm SP PETROL LAWNMOWER

GPMXSZ46I



Contents

Product images and parts list	6
General information.....	7
Reading and storing the instruction manual.....	7
Explanation of symbols.....	7
Safety.....	9
Proper use.....	9
Safety notes.....	9
Assembly.....	12
Installation.....	12
Remove the packaging.....	12
Assemble the lower handle.....	12
Assembling the hybrid collection box	13
Fix the cable.....	13
Getting started.....	13
Operation.....	16
Setting the Cutting Height	16
Starting the Engine.....	16
Mowing.....	18
Cleaning.....	20
Maintenance.....	21
Troubleshooting.....	25
Storage.....	26
Disposal.....	28
Technical data.....	29
EC Declaration of Conformity	
Warranty	
Warranty Card	
Warranty Conditions	

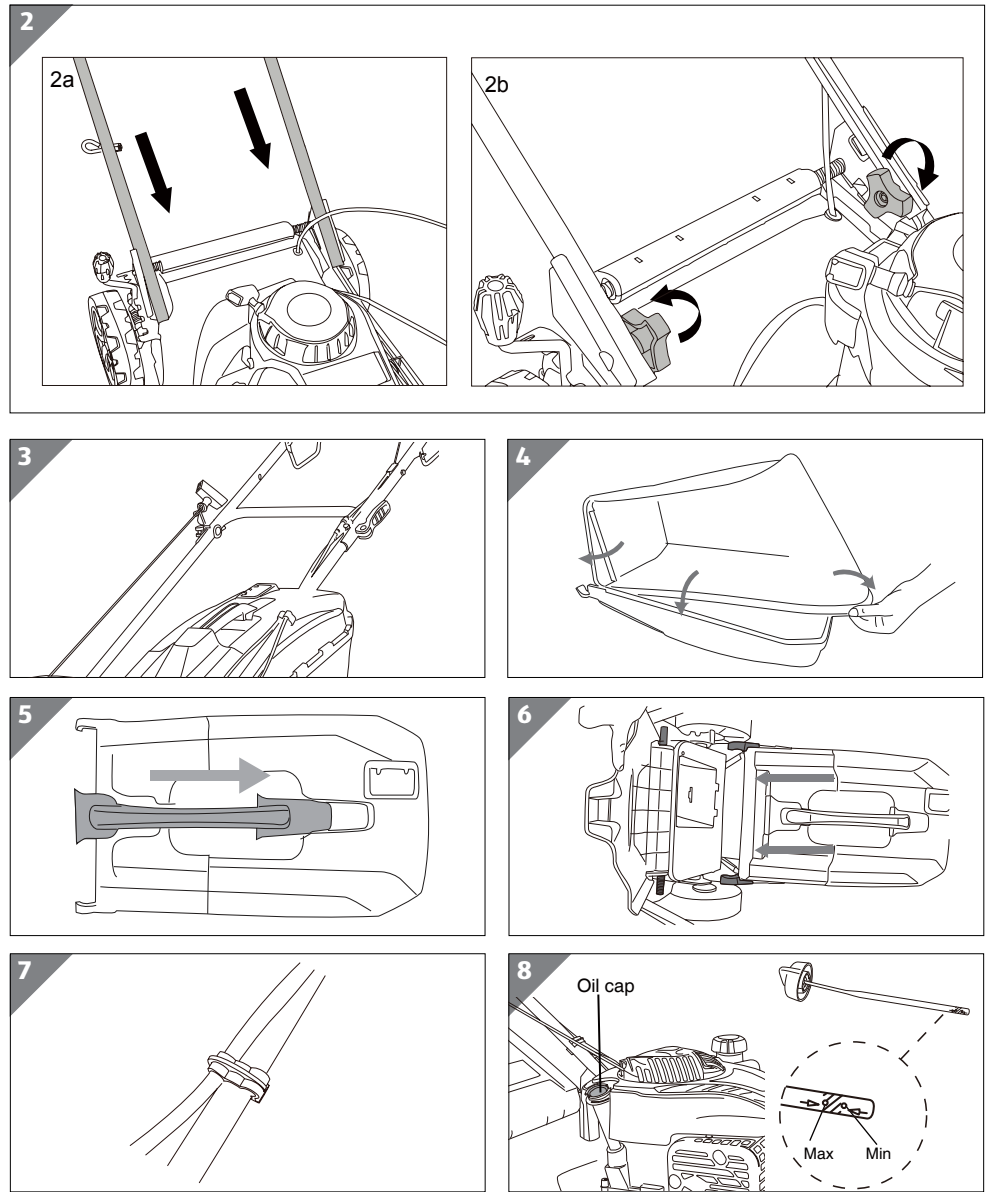
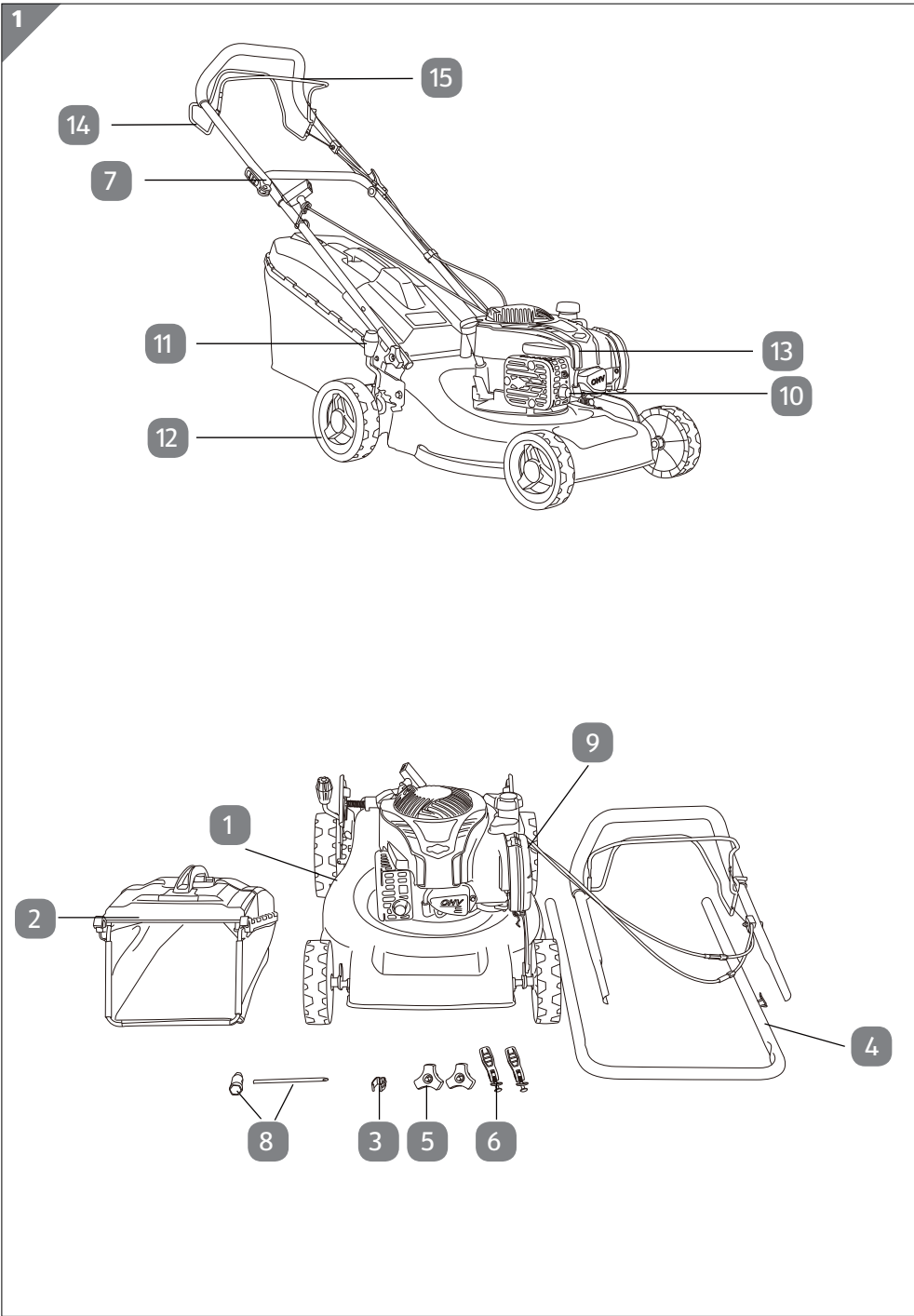

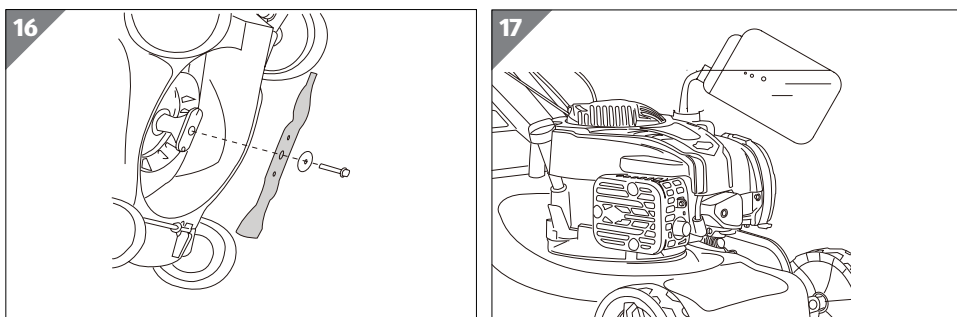
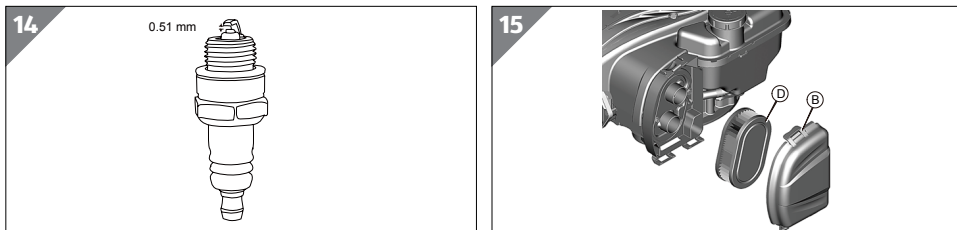
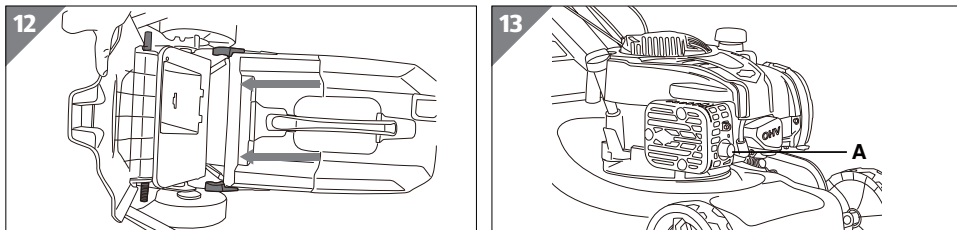
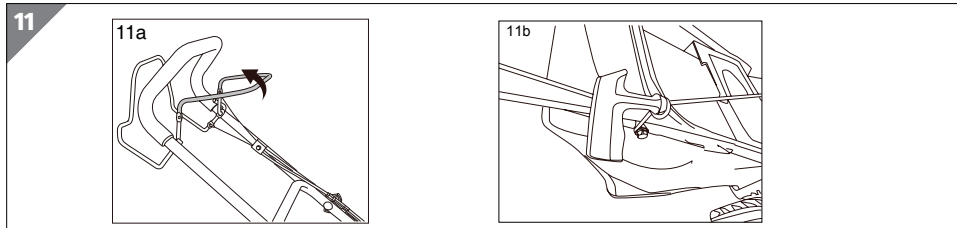
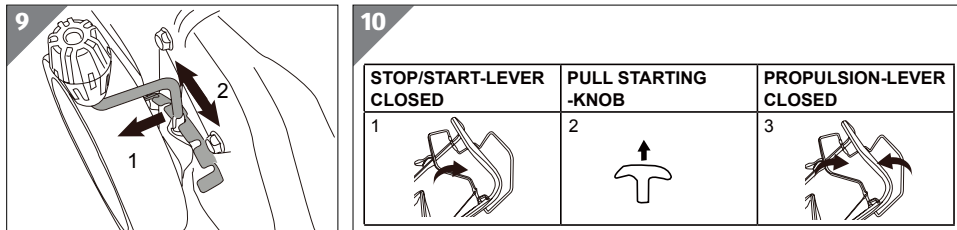

- 1 Main mower deck (with upper handle)
- 2 Hybrid collection box
- 3 Cable clip
- 4 Lower handle
- 5 Lower handle fixing knob with nut M8, x2
- 6 Quick release, x2
- 7 Rope guide (attached to the lower handle)
- 8 Socket spanner for spark plug
- 9 Air filter
- 10 Spark plug
- 11 Cut height adjuster
- 12 Wheel, x4
- 13 Briggs & Stratton engine
- 14 Propulsion lever
- 15 Start/stop bar

Reading and storing the instruction manual



This instruction manual accompanies this lawnmower. It contains important information on start-up and handling. Before using the lawnmower, read the instruction manual carefully. This particularly applies for the safety notes. Failure to heed this instruction manual may result in severe injury or damage to the lawnmower. The instruction manual is based on the standards and rules in force in the European Union. Store the instruction manual for future use. If you pass the lawnmower on to third parties, please ensure to include this instruction manual.

You can request an electronic version of these instructions from our customer service.

Explanation of symbols

The following symbols and signal words are used in this instruction manual, on the lawnmower or on the packaging.



Read the user manual before using the machine.





You must always wear safety goggles to guard your eyes from flying debris, ear plugs or similar ear defenders to protect your hearing and a safety helmet to protect against the risk of falling objects.

AFTER SALES SUPPORT



www.coreservice.co.uk



 +44 (0)1904 727501
 +353 (0)1 902 2605



Important! Wear gloves to protect your hands.



Wear safety boots to protect your feet.



Warning! Danger!



Sound level data (96 dB) in accordance with Directive 2000/14/EC



Keep bystanders away.



Beware of sharp blades- remove spark plug lead before maintenance.





No naked flames.



Hot surfaces will burn fingers or palms.

AFTER SALES SUPPORT



 +44 (0)1904 727501
 +353 (0)1 902 2605



www.coreservice.co.uk



Warning! The lawnmower exhaust gas contains toxic substances. Do not run the engine in closed or poorly ventilated areas.



Blade continues to rotate for a period after the machine is switched off. Do not touch the blade until all the machine components have been stopped completely.



Proper use

The lawnmower is designed exclusively for cutting grass. The manufacturer cannot be held liable for damage caused by improper or incorrect usage.

Please note that our equipment has not been designed for use in commercial, trade or industrial applications. Our warranty will be voided if the machine is used in commercial, trade or industrial businesses or for the equivalent purposes.

Safety notes



WARNING!

When using petrol tools, basic safety precautions, including the following, should always be followed to reduce the risk of serious personal injury and/or damage to the unit.

Read all these instructions before operating this product and keep them stored in a safe place for future reference.

- Keep this operating and maintenance manual in a safe place for reference at a later date.
- Read the instructions carefully. Be familiar with the controls and the proper use of the equipment.
- Never allow children or people unfamiliar with these instructions to use the lawnmower. Local regulations can restrict the age of the operator.
- Never mow while people, especially children or pets are nearby. Keep in mind that the operator or user is responsible for accidents or hazards occurring to other people or their property.
- This appliance is not intended for use by people (including



children) with reduced physical, sensory or mental capabilities, or lack of experience and knowledge, unless they have been given supervision or instruction concerning use of the appliance by a person responsible for their safety.

- Do not touch the rotating blade.
- While mowing, always wear substantial footwear and long trousers. Do not operate the equipment when barefoot or wearing open sandals;
- Thoroughly inspect the area where the equipment is to be used and remove all objects which can be thrown up by the machine;
- Petrol is highly flammable: store fuel in containers specifically designed for this purpose;
 - refuel outdoors only and do not smoke while refuelling;
 - add fuel before starting the engine. Never remove the cap of the fuel tank or add petrol while the engine is running or when the engine is hot;
 - If petrol is spilled, do not attempt to start the engine but move the machine away from the area of spillage and avoid creating any source of ignition until petrol vapours have dissipated;
 - replace all fuel tank and container caps securely;
- Replace faulty silencers;
- Prior to use, visually inspect to see that the blade, blade bolts and cutter assembly are not worn or damaged. Replace worn or damaged blades and bolts in sets to preserve balance;
- Keep all nuts, bolts and screws tight to be sure the equipment is in a safe working condition;
- Never store the equipment with petrol remaining in the tank inside a building where fumes can reach an open flame or spark;
- Allow the engine to cool before storing in any enclosure;
- To reduce the risk of a fire hazard, keep the engine, silencer,

AFTER SALES SUPPORT

11



www.coreservice.co.uk



GB +44 (0)1904 727501
IRE +353 (0)1 902 2605

and petrol storage area free of grass, leaves, or excessive grease;

- Check the grass bag frequently for wear or deterioration;
- Replace worn or damaged parts for continued safety;
- If the fuel tank has to be drained, this should be done outdoors.
- Do not operate the engine in a confined space where dangerous carbon monoxide fumes can collect;
- Mow only in daylight or in good artificial light;
- Where possible avoid operating the equipment on wet grass;
- Always be sure of your footing on slopes;
- Walk, never run;
- Mow across the face of slopes, never up and down;
- Exercise extreme caution when changing direction on slopes;
- Do not mow excessively steep slopes;
- Use extreme caution when reversing or pulling the lawnmower towards you;
- Stop the blade if the lawnmower has to be tilted for transportation when crossing surfaces other than grass, and when transporting the lawnmower to and from the area to be mowed;
- Never operate the lawnmower with defective guards, or without safety devices, for example deflectors and/or grass catchers, in place;
- Do not change the engine governor settings or over speed the engine;
- Start the engine carefully according to instructions and with feet well away from the blade;
- Do not tilt the lawnmower when starting the engine;
- Do not start the engine without the grass collector located;
- Do not put hands or feet near or under rotating parts. Keep clear of the discharge opening at all times;
- Never pick up or carry a lawnmower while the engine is running;

AFTER SALES SUPPORT

12



GB +44 (0)1904 727501
IRE +353 (0)1 902 2605



www.coreservice.co.uk

- Stop the engine and disconnect the spark plug cable, making sure that all moving parts have come to a complete stop:
 - Before clearing blockages or unclogging the chute;
 - Before checking, cleaning or working on the lawnmower;
 - After striking a foreign object, inspect the lawnmower for damage and make repairs before restarting and operating the lawnmower;
 - If the lawnmower starts to vibrate abnormally, check immediately;
- Stop the engine and disconnect the spark plug wire, make sure that all moving parts have come to a complete stop before refueling;



ENVIRONMENTAL PROTECTION

Dispose of soiled maintenance material and operating material at the appropriate collection point. Recycle packaging material, metal and plastics.



Assembly

Installation

Always take care when removing the packaging to prevent damage to you or to the lawnmower.

Before assembling the lawnmower, check all the parts indicated in the manual are in the box. Inspect all the parts for signs of damage. Do not assemble the lawnmower if you observe any damaged components.

1. Remove the packaging

- 1a. Remove all parts of the lawnmower from the box and carefully remove all packaging. Take care not to lose any instructions which may be attached to the parts. These provide important information which will be required while assembling the lawnmower.
- 1b. Keep all packaging until the lawnmower is fully assembled and has been operated successfully.

Note! Always recycle the packaging in accordance with local recycling schemes. This item requires a two person lift to remove from the packaging.

Make sure that you have sufficient space to put the lawn mower down. Keep your feet apart so that you have a stable position, bend at the knees and keep your back straight.

2. Assemble the lower handle (Fig 2)

- 2a Remove the packaging from the handle. Set the height adjustment to the highest position, and align the lower



handle with the holes in the deck. Make sure the holes in the lowerhandle are aligned with those in the support.

2b Fix the lower handle onto the deck firmly with fixing knob.

Note! Make sure the rope guide is on the right handle, when you stand behind the mower.

Lift the upper handle, and lock in place using the quick release lever and tensioning bolts that are attached to the handle.

Note! Make sure the lower and upper handles are firmly connected. And that the cables are not twisted (Fig 3).

Pull on/off lever and gently pull the rope. Hook it around the guide rope.

3. Assembling the hybrid collection box (Fig 4 , 5, 6)

Raise the safety flap and hook the hybrid collection box onto the mower. Release the safety flap.

Note! Always fit the hybrid collection box before starting the engine.

4. Fix the cable (Fig 7)

Ensure that the cables clips supplied are used to fix the cable to the lower handle.



Getting Started



PREPARING TO OPERATE THE LAWNMOWER STOP !!!

DO NOT START THE ENGINE BEFORE ADDING OIL TO THE OIL SUMP. WHEN ADDING, DON'T EXCEED THE MAXIMUM LINE.

Note! The following procedures and adjustments must be performed before the engine is started. Do not attempt to make any of these adjustments while the engine is running.

Note! Always use high quality detergent oil classified SAE30 oil (or equivalent eg 5W 30, often termed as 4 Stroke lawn mower oil). Never use additives with recommended oil. To prolong the life of your engine it is important that the oil is changed after the first 5 hours of use.

Note! To prevent engine damage the engine is shipped without oil or petrol. The engine must be filled with the correct grade of oil and petrol before starting the engine.

Note! Running the engine with a low oil level will cause engine damage. It is recommend that high detergent, premium quality 4-stroke engine oil used. Using non-detergent oil can shorten the engine's service life and using 2-stroke oil will damage the engine. Check the engine oil level when the engine is stopped and cool and the mower standing on a level surface.

Remove the oil filler dipstick and wipe any oil from it with a clean cloth.

Insert the dipstick into the oil filler neck, but do not screw it in. Then remove the dipstick and check the oil level. The oil level must be between the Min and Max marks on the dipstick. If near the lower level, fill to the upper level with the recommended oil



(SAE30 or equivalent). Do not overfill. Wipe away any spilt oil.

Fuel and lubrication

Note! Always use clean, fresh unleaded petrol. Purchase fuel in quantities that can be used within 30 days. Never mix oil with the petrol.

Note! Do not fill into the base of the tank neck to allow for fuel expansion. Do not overfill the fuel tank.

Note! Petrol is highly flammable and extreme precaution must be taken when handling or working with it. Keep out of reach of children.

Note! To prevent engine damage the engine is shipped without oil or petrol. The engine must be filled with the correct grade of oil and petrol before starting the engine.

Note! Refuel in a well-ventilated area with the engine stopped. Do not smoke or allow flames or sparks in the area where the engine is refueled or where petrol is stored. Avoid repeated or prolonged contact with your skin or inhalation of vapour. Clean the area around the petrol filler cap before removing the cap. Remove the warning tag, check the fuel level.

Refill the tank if the fuel level is low (fuel tank capacity is 0.8 L).

Refuel carefully to avoid overfilling or spilling fuel. There should be no fuel in the filler neck.

Clean up any overflow or splashes of petrol before starting the engine.

Tighten the filler cap after filling, finger tight only.

Note! Do not use wasted or regenerated oil that can cause damage to the engine.



Operation

1. Setting the Cutting Height (Fig 9)

Note! The blade can cause serious injury. Before adjusting the mower height, stop the engine and wait for the mower blade to stop completely.

Pull the lever towards the wheel, then move it forwards or backwards to adjust the cutting height. Move it to any one of the 7 positions (25~75mm) for the desired cutting height; Ensure the lever clicks into place.

2. Starting the Engine

Starting procedure quick guide (Fig 10)

Note! Do not operate the machine in enclosed or poorly ventilated areas as the exhaust contains toxic substances. Keep hands, feet, hair and clothing away from all the moving parts of the machine. The exhaust and other parts of the machine will become hot during use.

Note! To start the engine, make sure that the spark plug cap is located on the plug and the machine is filled with sufficient oil and petrol.

Start/Stop Bar Activation (Fig 11a)

Warning! Never start the engine before adding the right amount of oil to the engine. Failing to do so will result in irreparable damage.

Pull the Start/Stop bar towards you. (Fig 11a)



Pull cord handle

With right hand, slowly but firmly pull the starter handle (Fig 11b) and rope from the pull cord guide until you feel resistance, then pull briskly. When the engine starts, return the starter rope to its rest position gently.

Note! Clearing a flooded engine:

If the engine won't start after you have trying to start several times, the engine may be flooded with excess fuel.

Use the following procedure to clear and start a flooded engine:

- A. Release the stop/start bar.
- B. Remove the spark plug, dry it, and then reinstall it.

Note! Install the spark plug carefully by hand, to avoid cross threading.

After the plug is seated, tighten 1/8 to 1/4 turn with the spark plug socket spanner to compress the washer.

- C. Pull the stop/start bar toward the upper handle.
- D. Operate the starter as described above.



3. Mowing

Note! Always observe the strictest safety procedures when using the lawnmower.

Carefully read the safety instructions of this manual before using the lawnmower.

Start the engine and allow it to run. See "Step-2 Starting the engine". To stop the engine, release the stop / start bar.

Keep a firm grip on the upper handle with the stop/start bar and propulsion lever closed and walk along with it self-propelling, never run with the mower, be very careful when mowing uneven or rough ground. Mow across slopes, never up and down. Be careful when changing the direction of the mower on a slope. Do not use the mower on a steep slope of more than 15°.

The best result will be achieved if the grass is dry. Wet grass will tend to clog the blade and the grass collection system. Grass grows at different rates at different times of the year.

Never use the lowest cutting height for the first cut of the season or in drought conditions. Only about one third of the grass height should be cut.

If the lawnmower will not collect the cuttings efficiently, the grass discharge chute may be blocked. The hybrid collection box may be full, or the underside of the mower deck may be clogged.

Emptying the hybrid collection box

Note! Before you remove the hybrid collection box, stop the engine and wait until the blade stops completely.



Note! Always empty the hybrid collection box when you have finished the mowing, even if it is not full.

Stored grass residues are a fire hazard.

To remove the hybrid collection box, raise the discharge flap with one hand and remove the hybrid collection box using its handle with your other hand.

Empty the grass debris from the hybrid collection box, and refit it.

If any grass residues are caught in the discharge chute, clean it using a brush.

Do not remove grass debris in the mower casing or on the blade by hand or with your feet. Instead use suitable tools such as a brush or broom.

To ensure that the cut grass can be collected into the hybrid collection box, the discharge opening and inside the mower casing must be kept clear of any blockage.



Cleaning

Before cleaning, inspecting or repairing your unit, make sure that the engine has stopped and is cool. Disconnect the spark plug to prevent accidental starting.

Note! To ensure the best performance of your lawnmower, it is important to keep it clean.

Always clean your lawnmower immediately after use.

Note! Do not allow grass cuttings and other debris to become dry and hard on any of the mower surfaces. This will directly affect the cutting and grass collection performance. Make sure that the underside of the lawnmower deck is clean and clear.

Note! Never turn the mower upside down.

Note! Before you tip the lawn mower onto its side, completely empty the fuel tank using a petrol suction pump.

Note! Never clean the lawn mower with a water jet or high-pressure cleaner. The engine must remain dry. Do not use aggressive cleaning agents such as cold cleaner or petroleum ether.

1. The lawn mower should be thoroughly cleaned after every use, especially the underneath and the blade mount. Gently tip the mower back with the front wheels up in the air. Dirt and grass is easiest to remove immediately after you have finished mowing the grass.

2. Check that the grass chute is free of any residual grass. Remove any such residue.



Maintenance

Maintenance Schedule

Performing routine maintenance correctly on your lawnmower will ensure you get years of trouble free use.

Please keep this manual safe for future reference.

It is recommended that the following maintenance schedule is adhered to. This will ensure the lawnmower operates correctly and is safe to use.

	after every use	12 hours of use	24 hours of use	36 hours of use
Cleaning	clean	clean	clean	clean
Air filter		clean	clean	replace
Spark plug		clean	clean	replace
Engine oil	check	check	replace	check
Cutting blade	check	check	check	check

Maintenance Operations

Spark Plug

- Once the engine has cooled, pull off the spark plug boot with a twist. Remove the sparkplug using the socket spanner supplied.

- Clean the plug with a wire brush.
- Using a feeler gauge set the gap to 0.51mm.
- Install the spark plug carefully by hand, to avoid cross threading.
- After the spark plug is seated, tighten with the spanner to compress the washer.

Air Filter

Note! Never run the engine without the air filter element installed.

The air cleaner system uses a pleated filter.

- Open the cover (B).
- Remove the filter(D).
- To loosen debris, gently tap the filter on a hard surface. If the filter is excessively dirty, replace with a new filter.
- Install the filter(D).
- Close the cover(B).

Oil

Tilt the lawnmower towards the oil filler, have a container ready to catch the oil and remove the dipstick. Once the oil has been emptied, wipe clean any spillages.

Refill with 470ml SAE30 oil or equivalent (ie SAE5W/30, SAE10W/30). When the dipstick is rested on the filler pipe (i.e. not screwed in place), the oil level must be between the min and max marks on the dipstick (Fig 8).

See “Filling with Engine Oil”. Do not overfill.

Start the engine and allow it to run briefly.

Stop the engine, wait one minute and check the oil level. Top up if necessary.

Note! For more information see the Engine Manual.

Blades

For safety reasons you should only ever have your blade sharpened, balanced and mounted by an authorised service workshop. For optimum results it is recommended that the blade should be inspected once a year.

Note! For engine maintenance, see more details in the Engine Manual.

Note! Before you remove the hybrid collection box, stop the engine and wait until the blade stops completely.

Note! You will need garden gloves (not provided) and a spanner wrench to remove the blade.

Note! Always handle the blade with care- sharp edges could cause injury USE GLOVES.

Renew your metal blade after 50Hrs mowing or 2yrs whichever



is sooner regardless of condition.

Note! If the blade is cracked or damaged replace it with a new one.

Note! Don't hold the blade by hand directly.

Note! Maintain the sharpness of the blade when cutting grass. If the blade has worn excessively and become pitted and blunt, it should be replaced or sharpened. The sharpness of the blade will affect the performance of the lawnmower.

For safety reasons we recommend that the blade only be changed by someone qualified and authorised to do so.

1. Tip machine backwards .
2. Hold the blade and unscrew the blade bolt counterclockwise using a spanner wrench. Remove the washer and the blade.
3. Inspect the blade adaptor on any signs of damage.
4. Fit a new blade, locate the blade on the two studs on the blade flange and then replace the washer and bolts.
5. Check the washer is still slightly domed to keep the pressure on the bolt to stop it unwinding, keeping the blade firmly secure. Then replace the washer (right way around!) and bolts (Fig 16).
6. Make sure the blade is correctly located, and then firmly tighten the bolt. Do not over tighten.



Troubleshooting

Fault	Possible cause	Troubleshooting
Heavy vibration when running	Screws are loose	Check screws
	Blade fasteners are loose	Check blade fasteners
	Blade is un-balanced	Replace blade.
Engine does not start	Start/stop bar not pressed	Press start/stop bar
	Spark plug is defective	Replace spark plug
	Fuel tank is empty	Adjust the scarifying depth.
	Engine may be flooded	Remove plug and dry
The scarifying results are inconsistent.	Air filter is soiled	Clean the air filter
	Spark plug is soiled	Clean the spark plug
Uneven mowing results	Blade is blunt	Sharpen the blade
	Cutting height is too low	Set correct height
Unsatisfactory bagging of the grass	Cutting height is too low	Set correct height
	Blade is worn	Replace the blade
	Collection box is clogged	Empty the grass bag



STORAGE

Storing the Lawnmower for Short Periods

The lawnmower can be stored for short periods of time (less than 15 days) without performing any storage maintenance.

Before placing the lawnmower into storage always carry out the following:

- Allow the engine to fully cool.
- Ensure the Collection box is empty.
- Clean all debris from under the mower deck.
- Store the lawnmower on a flat and level surface with all 4 wheels on the ground upright.
- Store in a safe place which is not accessible by children or people who are not familiar with operation.



WARNING

Do not empty the petrol tank in enclosed areas, near fire or when smoking. Petrol fumes can cause explosions and fire.

Storing the Lawnmower for Extended Periods

If the lawnmower is to be placed into storage for longer periods of time, storage maintenance must be performed on the lawnmower.

If the following steps are not carried out, when you next operate the lawnmower it may not start correctly and may need to be serviced.



Note! Do not empty the petrol tank in enclosed areas, near fire or when smoking. Petrol fumes can cause explosions and fire.

1. Empty the petrol tank with a petrol suction pump if available or run the machine until all the fuel has been used and automatically stops.
2. Start the engine and let it run until any remaining petrol has been used up.
3. Change the oil at the end of every season. To do so, remove the used engine oil from a warm engine and refill with fresh oil.
4. Remove the spark plug from the cylinder head. Fill the cylinder with approx. 20 ml of clean engine oil from an oil can. Slowly pull back the starter handle, which will bathe the cylinder wall with oil. Screw the spark plug back in.
5. Clean the cooling fins of the cylinder and the housing.
6. Be sure to clean the entire machine to protect the paint.
7. Store the machine in a well-ventilated place.

Waste disposal

The equipment and its accessories are made of various types of material, such as metal and plastic. Defective components must be disposed of as special waste. Ask your dealer or your local council.



Disposal

Disposing of the packaging



Dispose of the packaging separated into single type materials. Dispose of cardboard and carton as waste paper and foils via the recyclable material collection service.

Disposing of old devices

(Applicable in the European Union and other European states with systems for the separate collection of reusable waste materials)



Old devices must not be disposed of with household waste!

If the lawnmower can no longer be used, every user is required by law to dispose of old devices separately from their household waste, e.g. at a collection point in his community/borough. This ensures that old devices are recycled in a professional manner and also rules out negative consequences for the environment.



Technical data

Engine type	4 Stroke. Single cylinder
Engine displacement	140cc
Engine max. power	2.1kW/2900/min
Engine speed	2900rpm
Cutting width	46cm
Collection box capacity	60l
Ignition	T.C.I
Fuel tank	0.8L
Oil tank	0.47L
Sound pressure level	83 dB(A)
Sound power level	96 dB(A)
Vibration	6.5m/s ² K=1.5m/s ²
Spark plug	QC12YC (Champion)
Net weight	27.5kg

Vibration levels and noise emission levels measured in accordance with DIN EN 60335. The specified vibration level can be used to compare one power tool with another one. The vibration value may also be used to introductorily assess the exposure.

SUMEC

Declaration of CE Conformity

We
SUMEC Hardware & Tools Co., Ltd.
 1 Xinghuo RD., Nanjing, China
 And our branch office
SUMEC UK Co., Ltd.
 Unit A&B, Escrick Business Park
 Escrick, York YO 19 6FD
 Declare that the product
Gasoline Lawn Mower
Model No: XSZ461
Function: Cutting grass
Serial number :00001-11102

Complies with the following directives:
EMC Directive: 2004/108/EC
Machinery Directive: 2006/42/EC
Noise Directive: 2000/14/EC amended by 2005/88/EC
 Standards conform to:
EN ISO 14982:2009
EN5395-1:2013
EN 5395-2:2013

We additionally confirm the following in accordance with the
2000/14/EC emissions guideline:
Conformity Assessment Procedure as Per Annex VI,
Measured sound capacity level :94.91 dB (A)
Guaranteed sound capacity level: 96 dB (A)

Authorized Signatory

Date: 2015-09-18

Signature:
 Name: Liu Kai

General Manager
 SUMEC Hardware & Tools Co., Ltd.





WARRANTY CARD

GB IRE

46cm SP PETROL LAWMOWER GPMXSZ46I

Your detail:

Name _____

Address _____



E-Mail _____

Date of purchase * _____

* We recommend you keep the receipt with this warranty card.

Location of purchase _____

Description of malfunction :



Return your completed warranty card together with the faulty product to:

Unit A&B
Escrick Business Park
Escrick
York
YO19 6FD

Email: support@coreservice.co.uk
Tel: 01904 727501

AFTER SALES SUPPORT

☎ GB +44 (0)1904 727501
IRE +353 (0)1 902 2605 🌐 www.coreservice.co.uk

MODEL: GPMXSZ46I, 03/2016, 60469

Phone lines available
Mon - Fri : 9am - 5pm
Sat - Sun: 11am - 4pm.
Calls are charged at local rate,
mobiles may vary.



GB IRE

Warranty conditions

Dear Customer,

The **ALDI warranty** offers you extensive benefits compared to the statutory obligation arising from a warranty:

Warranty period: **3 years** from date of purchase
6 months for wear parts and consumables under normal and proper conditions of use (e.g. rechargeable batteries).

Costs: Free repair/exchange or refund.
No transport costs.

Hotline: Support line charged at local rate

ADVICE: Please contact our service hotline by phone, e-mail or fax before sending in the device. This allows us to provide support in the event of possible operator errors.

In order to make a claim under the warranty, please send us:

- Together with the faulty item the original receipt and the warranty card properly completed.
- The faulty product with all components included in the packaging.

The warranty does not cover damage cause by:

- **Accident or unanticipated events.** (e.g. lighting, water, fire)
- **Improper use or Transport.**
- **Disregard of the safety and maintenance instructions.**
- Other **improper treatment or modification.**

After the expiry of the warranty period, you still have the possibility to have your product repaired at your own expense. If the repair or the estimate of costs is not free of charge you will be informed accordingly in advance.

This warranty does not limit the statutory obligation of the seller arising from a warranty. In the event that a product is received for repair, neither the service company nor the seller will assume any liability for data or settings possibly stored on the product by the customer.



Spend a little Live a lot

Great care has gone into the manufacture of this product and it should therefore provide you with years of good service when used properly. In the event of product failure within its intended use over the course of the first 3 years after date of purchase, we will remedy the problem as quickly as possible once it has been brought to our attention. In the unlikely event of such an occurrence, or if you require any information about the product, please contact us via our helpline support services, details of which are to be found both in this manual and on the product itself.



Importer:
SUMEC UK
UNIT A&B ESCRICK BUSINESS PARK
ESCRICK, YORK, YO19 6FD, UK

Email: support@coreservice.co.uk

AFTER SALES SUPPORT



GB +44 (0)1904 727501
IRE +353 (0)1 902 2605



www.coreservice.co.uk

MODEL: GPMXSZ461, 03/2016, 60469

3

YEARS WARRANTY