

SOVEREIGN

EASY GARDENING

41cc PETROL CHAINSAW

Item No. 555378

Model No. CS4100A-5



Technical Support & Parts
01904 727509
Mon-Fri 9am-5pm Sat-Sun 11am-4pm
www.gardenservicecentre.co.uk

INSTRUCTION MANUAL

Please read these instructions fully before starting assembly.

CONTENTS

General safety warning	3
Intended use	10
Warning symbols	10
In the box	12
Preparing to assemble the chainsaw	13
Operating the chainsaw	18
Maintenance and storage	27
Technical data	36
Troubleshooting	38
Disposal	40
Getting help	40
Warranty	40

GENERAL SAFETY WARNINGS

Safety Warnings



WARNING! Read all safety warnings and instructions.

Failure to follow the warnings and instructions may result in electric shock, fire and/or serious injury.



WARNING! Read all safety warnings and instructions designated by the  symbol. Save all warnings and instructions for future reference.

- Always ensure anyone intending to operate this chainsaw is fully conversant with the contents of this assembly manual prior to assembling, maintaining or operating the chainsaw.
- Perform assembly operations as described in this manual. Failure to observe this warning may lead to serious injury, death, or damage to the chainsaw.
- Always take care when removing the packaging, to prevent damage to you or to the chainsaw.

IMPORTANT! Before assembling the chainsaw, check all the parts indicated in the manual are in the box. Inspect all the parts for signs of damage. Do not assemble the chainsaw if you observe any damaged components.

GENERAL SAFETY

- The chain is designed exclusively for sawing wood. You may only fell trees if you have received the appropriate training. The manufacturer cannot be held liable for damage caused by improper or incorrect usage. PLEASE NOTE: Our equipment has not been designed for use in commercial, trade or industrial applications. Our warranty will be voided if the machine is used in commercial, trade or industrial businesses or for the equivalent purposes.

PREPARATION

- DO NOT operate a chainsaw with one hand! Serious injury to the operator, helpers, or bystanders may result from one-handed operation. A chainsaw is intended for two-handed use only.
- DO NOT use the saw if you are tired, ill or under the influence of alcohol and/or drugs, or medication.
- Use safety footwear, snug-fitting clothing, and protective gloves, as well as eye, hearing and head protection devices (PPE).
- Use caution when handling fuel. Move the chainsaw at least 10 feet (3m) away from the fuelling point before starting the engine.
- DO NOT allow other persons to be near when starting or cutting with the chainsaw. Keep bystanders and animals away from the work area.
- DO NOT start cutting until you have a clear work area, secure footing, and a planned retreat path from falling trees or branches.

OPERATION

- Keep all parts of your body away from the saw's chain when the engine is running.
- Before you start the engine, make sure that the chain is not in contact with anything.
- Carry the chainsaw with the engine stopped, the chain bar and saw chain facing rearwards, and with the exhaust away from your body.
- NEVER use a chainsaw which is damaged, incorrectly set, incomplete or loosely assembled. Make sure that the chain rotation stops when the chain brake is applied.
- Shut off the engine before setting the chainsaw down.
- Use extreme caution when cutting small bushes and saplings; slender material may catch in the saw chain and be whipped towards you or pull you off balance.
- When cutting a limb that is under tension, be alert for spring back so that you will not be struck when the tension in the wood fibres are released.
- Keep the handles dry, clean, and free of oil or fuel mixture.
- Operate the chainsaw only in well-ventilated areas.
- DO NOT operate a chainsaw from up in a tree unless you have been specifically trained to do so.
- All chainsaw servicing, other than the items listed in the user manual safety and maintenance

instructions, should be performed by competent chainsaw service personnel.

- When transporting your chainsaw, use the appropriate chain bar cover.
- DO NOT operate your chainsaw near or around flammable liquids or gases, whether inside or outdoors. An explosion and/or fire may result.
- DO NOT fill the fuel tank, oil reservoir or lubricate whilst the engine of the chainsaw is running.
- USE THE CORRECT TOOL: Cut wood ONLY. Do not use the chainsaw for purposes for which it was not intended. For example, do not use the chainsaw for cutting plastic, masonry or building materials.
- The engine will create toxic exhaust fumes as soon as the engine is started. Never work in enclosed areas or in areas with poor ventilation.
- NOTE: The chainsaw is designed for non-commercial, occasional use and for general work, such as stump grubbing, and cutting firewood, etc. It is not designed for lengthy use. If it is used for a lengthy period, the vibrations it causes in the hands of the user may result in circulation problems (white finger syndrome).
- The chain is designed exclusively for sawing wood. You may only fell trees if you have received the appropriate training. The manufacturer cannot be held liable for damage caused by improper or incorrect usage.
- PLEASE NOTE: Our equipment has not been designed for use in commercial, trade or industrial

applications. Our warranty will be voided if the machine is used in commercial, trade or industrial businesses or for the equivalent purposes.

KICKBACK

Kickback may occur when the nose or tip of the chain bar touches an object, or when the wood closes in and pinches the saw chain in the cut. If the bar tip contacts, it may cause an extremely fast reverse reaction, kicking the chain bar up and back towards the operator. Pinching the saw chain along the top of the chain bar may push the chain bar rapidly back towards the operator. Either of these reactions may cause you to lose control of the saw, which could result in serious personal injury. Do not rely exclusively upon the safety devices built into your saw. As a chainsaw user, you should take several steps to keep your cutting jobs free from accident or injury.

- **NOTE:** With a basic understanding of kickback, you can reduce or eliminate the element of surprise. Sudden, unexpected action contributes to accidents.
- Keep a good firm grip on the saw with both hands: the right hand on the rear handle, and the left hand on the front handle, when the engine is running. Use a firm grip with thumbs and fingers encircling the chainsaw handles. A firm grip will help you reduce kickback and maintain control of the saw. Never let go of the chainsaw when it is running.
- Make sure that the area in which you are cutting is free from obstructions. Do not let the nose of the chain bar contact a log, branch, or any other

obstruction which could be hit while you are operating the saw.

- Cut at high engine speeds.
- DO NOT overreach or cut above shoulder height.
- Follow the manufacturer's sharpening and maintenance instructions for the saw chain.
- Only use replacement bars and chains specified by the manufacturer or the exact equivalent.
- PINCHING the saw chain along the BOTTOM of the cutting (chain) bar may PULL the saw forward away from the operator.
- PINCHING the saw chain along the TOP of the cutting (chain) bar may PUSH the chain bar rapidly back towards the operator.
- Any of these reactions may cause you to lose control of the saw, which could result in serious personal injury.

Beware of the following: Rotary recoil. A = Recoil direction. B = Recoil reaction zone. Impact/jamming recoil and pulling reactions: When cutting from under an object (see Pic. D) using the top of the chain, the object may pinch the chain and cause either a forward force on the chainsaw or a rearward force on the object (see Pic. C).

When cutting from the top surface of an object (Pic. E) using the bottom of the chain, the object may pinch the chain and cause either a rearward force on the chainsaw or a forward force on the object.

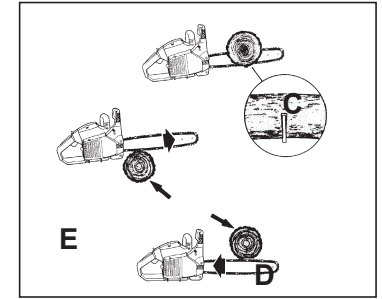
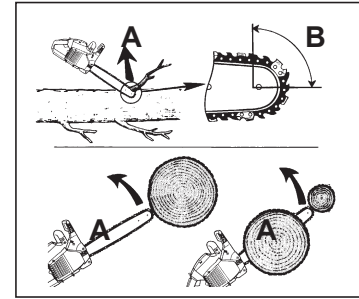

MAINTENANCE AND STORAGE

- Keep all nuts, bolts and screws tight, to be sure the equipment is in safe working condition.
- Never store the equipment with petrol in the tank inside a building where fumes can reach an open flame or spark.
- Allow the engine to cool before storing in any enclosure.
- To reduce the fire hazard, keep the engine, silencer and petrol storage area free of hedge trimmings, leaves, or excessive grease.
- Replace worn or damaged parts for safety.
- If the fuel tank has to be drained, this should be done outdoors.

NOTE: Dispose of soiled maintenance material and operating materials at the appropriate collection point. Recycle packaging material, metal and plastics. Do not dispose of with domestic, household waste.

INTENDED USE

This machine may only be used outdoors for cutting wood and in combination with the original cutting chains. This machine is not designed for heavy-duty or commercial use. Any use of the machine that deviates from its intended use, and is not included in these instructions, is considered unauthorised use and relieves the manufacturer from his or her legal liability.

WARNINGS SYMBOLS



Before any use, refer to the corresponding paragraph in the manual.



This symbol, before a safety comment, indicates a precaution, a warning or a danger. Ignoring this warning can lead to an accident for yourself or for others. To limit the risk of injury, fire, or electrocution, always apply the recommendations indicated.



Conforms to European Standards.



The exhaust gas is poisonous and asphyxiating. If inhaled, it may even be lethal. Do not operate the engine in closed or poorly-ventilated places.



Petrol and petrol vapours are extremely flammable.



DO NOT touch to prevent burns.



Wear hearing protection and eye protection (PPE) when using the device.



Wear robust footwear when using the device.



Wear protective gloves when using the device.



Guaranteed sound power level data (114dB), in accordance with Directive 2000/14/EC.



Beware of kickback (recoil).



Avoid contact with the tip of the guide bar (chain return point). This will result in kickback of the chainsaw.



DO NOT hold the saw with one hand.



Hold the saw firmly with both hands. Place your right hand on the rear handle and your left hand on the front handle.



DO NOT start or use the equipment close to people (especially children) or animals. During operation, it is recommended that a minimum distance of 10 metres from other people is maintained.

IN THE BOX

PARTS

A. Chainsaw

TOOLS

- B. Blade cover
- C. Mixing bottle
- D. Plug wrench
- E. Screwdriver

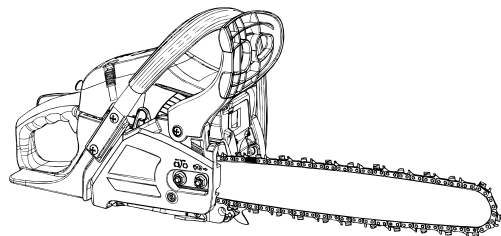

A

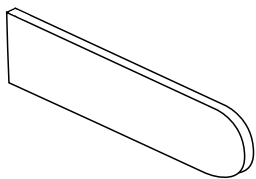

B

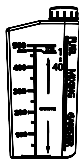

C

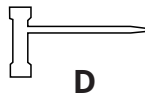

D

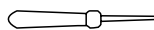

E

You will also need 2-Stroke engine oil according JASO FC classic, unleaded fuel and special chainsaw oil.

Any parts missing? Call the customer helpline on 01904 727509, most parts can be sent out on next day delivery.

PREPARING TO ASSEMBLE THE CHAINSAW Safety Features

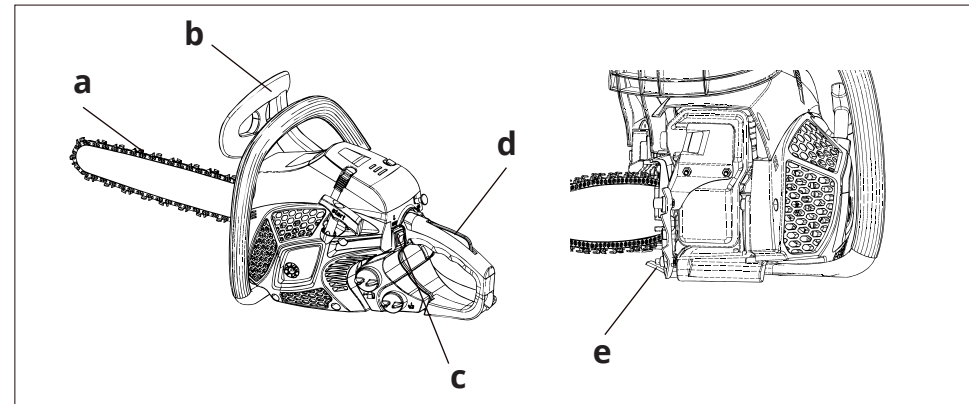

a. **LOW KICKBACK SAW CHAIN:** helps significantly reduce kickback, or the intensity of kickback, due to specially designed depth gauges and guard links.

b i. **CHAIN BRAKE:** is a safety feature designed to reduce the possibility of injury due to kickback by stopping a moving saw chain in milliseconds. It is activated by the **CHAIN BRAKE** lever.

b ii. **CHAIN BRAKE LEVER/HAND GUARD:** protects the operator's left hand in the event it slips off the front handle (while the saw is running) in the event of kickback.

c. **STOP SWITCH:** immediately stops the engine when tripped. The stop switch must be pushed to the 'START' position to start or restart engine.

d. **SAFETY TRIGGER LOCK:** prevents accidental acceleration of the engine. The throttle trigger cannot be squeezed unless the safety latch is de-pressed.

e. **CHAIN CATCHER:** reduces the danger of injury in the event that the saw chain breaks or derails during operation. The chain catcher is designed to intercept a whipping chain.

NOTE: Study your saw and be familiar with its parts.

STEP 1 - CHAIN BRAKE MECHANICAL TEST



WARNING!

The purpose of the chain brake is to reduce the possibility of injury due to kickback; however, it cannot provide the intended measure of protection if the saw is operated carelessly.

Always test the chain brake before using your saw and periodically while on the job.

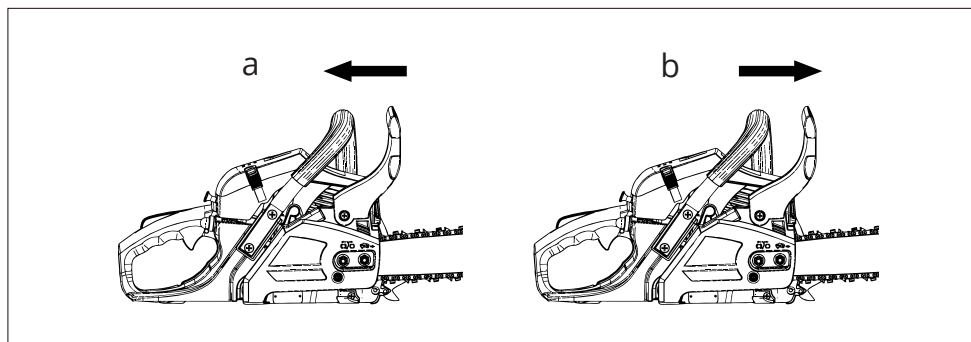

Your chainsaw is equipped with a chain brake that reduces the possibility of injury due to kickback. The brake is activated if pressure is applied against the brake lever when, as in the event of kickback, the operator's hand strikes the lever. When the brake is actuated, chain movement stops abruptly.

Before starting, test the chain brake by pushing it forward until an audible click is heard.

- The chain brake is **DISENGAGED** (chain can move by hand) when the **BRAKE LEVER IS PULLED BACK AND LOCKED**.
- The chain brake is **ENGAGED** (the chain is locked) when the brake lever is pushed forward. It should not be possible to move the chain by hand.



WARNING! The brake lever should snap into both positions. If this is not the case, do not use your saw. Contact the helpline immediately on 01904 727509.

STEP 2 - ADJUST THE CHAIN TENSION

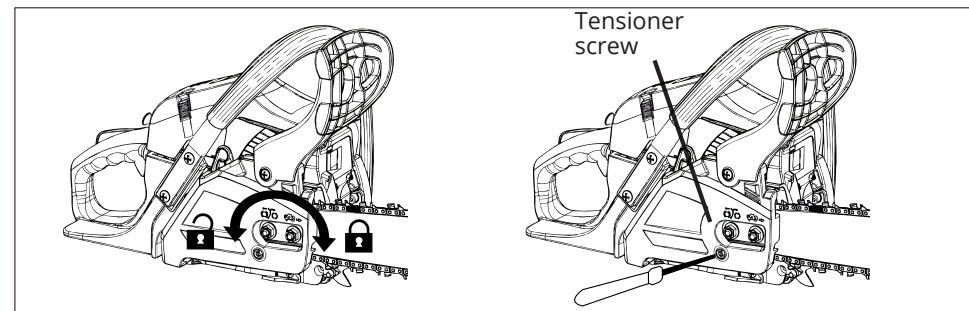

The motor must be switched off before adjusting the chain tension.

- Slightly loosen the chain cover nuts.
- Make sure that the chain is inside the groove of the guide. Hold the guide by its tip. Adjust the tension until the chain teeth touch the bottom of the guide.

Turn the chain tension adjustment clockwise until the chain is tight. Do not stretch the chain too much. Check the tension of the chain and check if the casing is properly tightened. If this is not the case, please repeat the procedure.

NOTE: When tensioned correctly, it should be possible to pull one full chain link free of the bar channel with ease. A new chain will expand its length during the first period of use. Check and re-adjust the tension frequently, as a loose chain can easily derail or cause rapid wear of itself and the chain bar.

CAUTION! If the saw chain is **TOO LOOSE** or **TOO TIGHT** the V-drive wheel, chain bar, chain and crank shaft bearing will suffer premature wear. Below Fig. shows the correct tension A (when cold) and tension B (when warm). Fig. C shows a chain that is too loose.

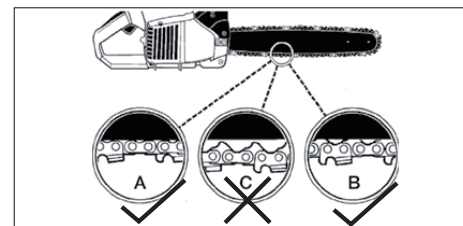

STEP 3 - FILLING WITH ENGINE FUEL

This product is powered by a 2-stroke engine and requires pre-mixing of petrol and 2-stroke oil. Use a high quality 2-stroke engine oil according JASO FC classic. Do not use automotive oil or 2-stroke outboard oil. DO NOT mix quantities larger than usable in a 30-day period.

FUEL MIXTURE: Petrol: 2-stroke engine oil = 40:1 ratio.

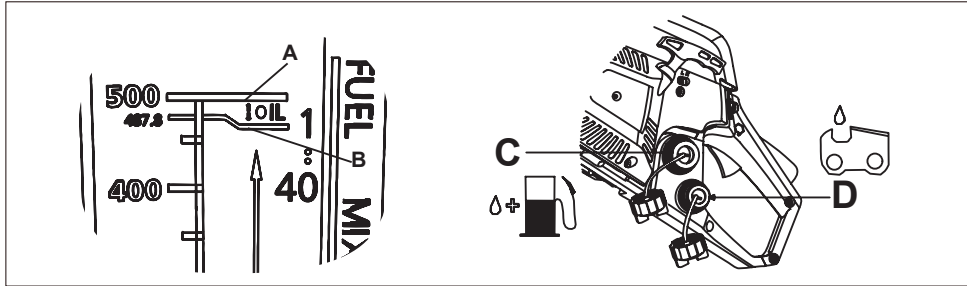

NOTE: There are two faces of this bottle one is 40:1, and the other is 25:1, please always use 40:1 for reference.

Using a funnel and keeping the bottle level, pour the petrol firstly in the left hand side (B) up to the required level and pour oil up to the (A) marking level. Shake vigorously to mix the petrol and oil prior to pouring into the tank (C).

Clean the surface around the fuel cap to prevent contamination. Loosen fuel cap slowly. Rest the cap on a clean surface. Carefully pour the fuel into the tank. Avoid spillage. Prior to fastening the fuel cap, clean and inspect the seal located inside the fuel cap. Immediately replace the fuel cap and hand tighten. Wipe up any fuel spillage.

NOTE: It is normal for smoke to be emitted from a new engine after first use.

STEP 4 - FILLING THE LUBRICATION OIL

Whenever you refill the fuel tank with petrol, you must also top up the level of chain oil in the chain oil reservoir. Use special chainsaw oil to lubricate the saw chain.

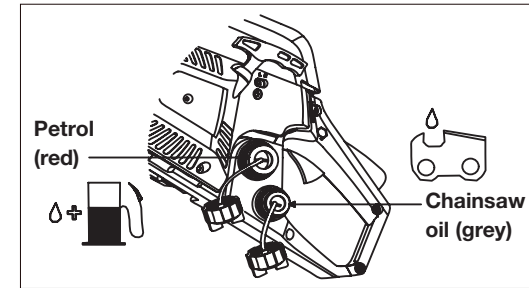

WARNING! Lack of chain oil will seriously damage the chain.

NOTE: Most stores will sell acceptable oil under the name 'chainsaw chain oil'.

IMPORTANT! The fuel mix is added into the fuel tank (C), chain lubrication oil is filled into the oil reservoir (D). Seal one cap prior to removing the second cap. If you put the fluid into the wrong tank, you must seek assistance from an expert immediately.

OPERATING

STEP 1 - START THE ENGINE



WARNING!

Do not start the engine whilst holding the chainsaw in one hand. There is a risk that the chainsaw may touch your body. This is very dangerous.

1. Set the switch to the '1' position.

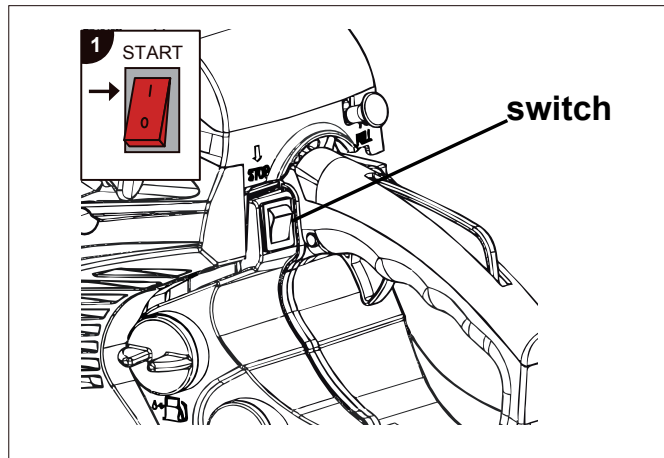

2. Engage the chain-brake (push it forward until an audible click is heard).

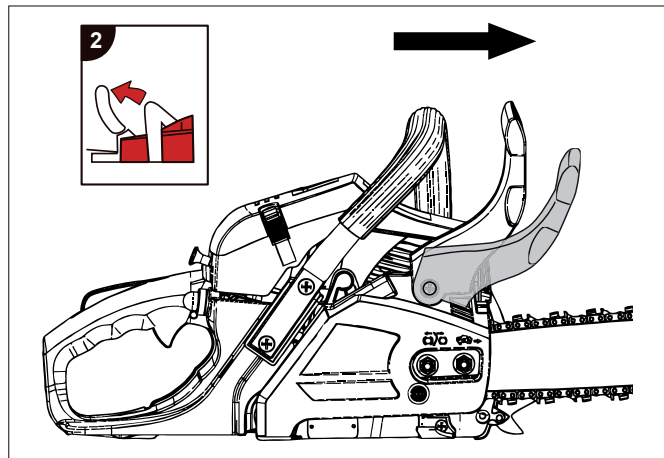

3. Press and release the primer bulb 10 times.
4. Pull the choke control out to engage.

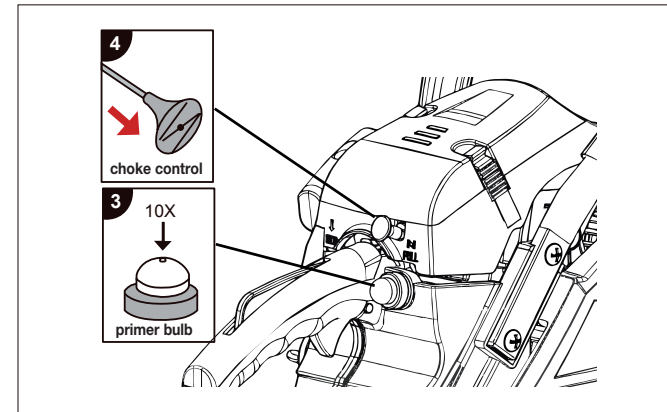

5. While holding the saw unit securely on the ground (one foot holding down the rear handle, left hand holding the front handle), pull the start handle four times to warm the engine. At this stage, the engine will usually not start.

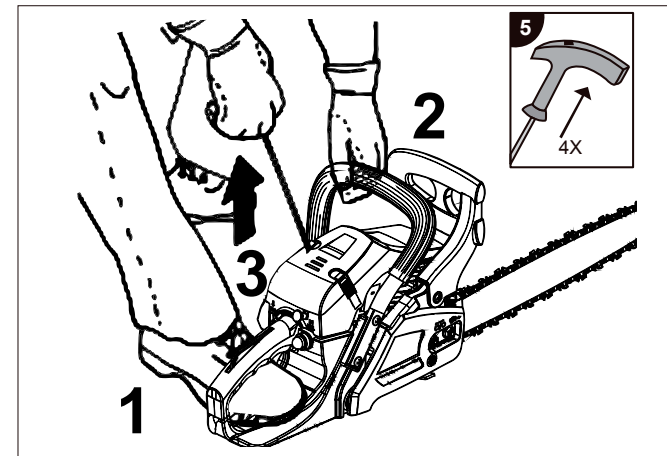

6. Push the choke control in to disengage. (Failure to do this may cause the engine to flood).

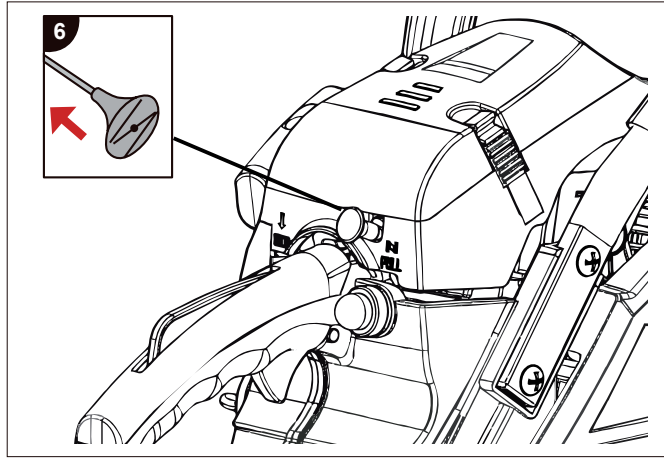

7. Pull the start handle in a smooth action to start the engine; the engine will usually start after 5 pulls. If the engine does not start, remove the spark plug, dry it with a paper towel and replace. Repeat the starting procedure.
8. After the engine starts, allow the saw to run and warm up in this position for 15 seconds.

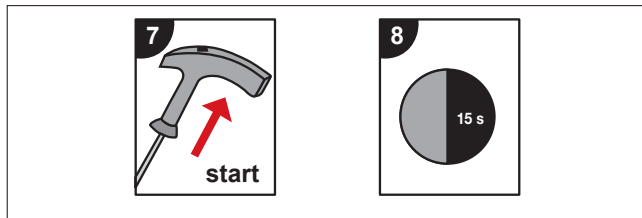

9. Disengage the chain brake by pulling it back.

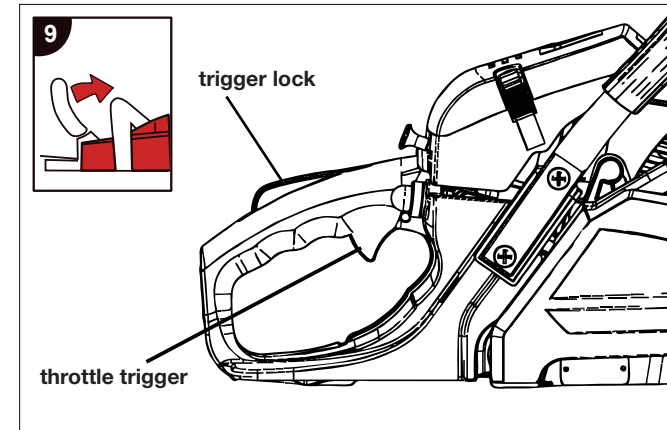

10. Push the safety trigger lock firstly and engage the throttle trigger.

STEP 2 - CHECKING THE OIL SUPPLY

With the chainsaw fully assembled and adjusted, it is important to check the chain oil supply is dispensing adequate lubrication.

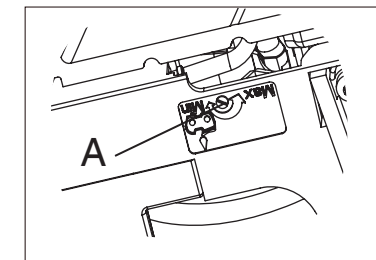
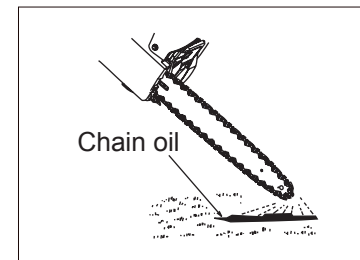

After starting the engine, run the chain at medium speed and see if chain oil is being dispensed as shown. With the chainsaw switched off, the chain oil flow can be changed by inserting a screwdriver in the hole on the bottom of the side of the clutch. Increase or decrease the oil flow according to your work conditions. Restart the chainsaw and check the rate of flow meets your requirements.

NOTE: The oil reservoir should become nearly empty by the time fuel is used up. Be sure to refill the oil reservoir every time when refuelling the saw.

STEP 3 - CHECK THE CHAIN BRAKE

This machine is equipped with a chain brake that will immediately disable the chain upon the occurrence of kickback during cutting. The brake is automatically operated by inertia forces, which act on the weight fitted inside the front guard. This brake can also be operated manually with the front guard pushed forward to the guide bar. To disengage the chain brake, pull it back until it touches the front handle.

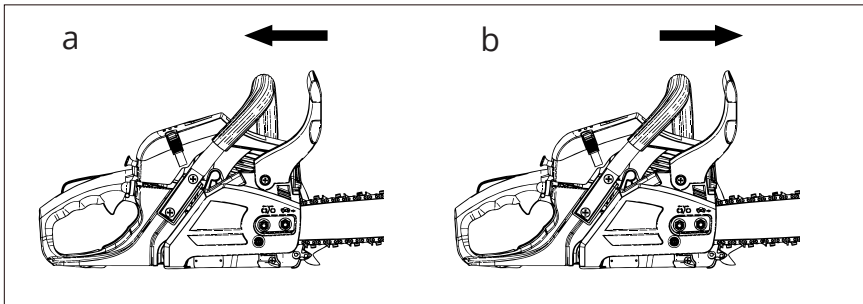

a= brake disengaged

b= brake engaged

IMPORTANT! Be sure to confirm the correct brake operation every time you use the machine, and periodically during use.

How to confirm if the chain brake is functioning correctly

1. Turn off the engine and leave until it is cold.
2. With the chainsaw on a flat surface and the chain tensioned correctly, engage the chain brake by pushing it forward until an audible click is heard. Then, wearing protective gloves, attempt to move the chain by hand in the direction of normal rotation; if this is not possible, the chain brake has been engaged. If the brake is engaged when the chain is rotating at high speed for extended periods of time, this can cause damage to the clutch or for it to fail completely. When the brake is activated whilst cutting, immediately release it, having first released the throttle lever, and set the chainsaw to 'O'. Call the service centre for more help.

STEP 4 - STOP THE ENGINE

1. Release the throttle lever to allow the engine to idle for a few seconds.
2. Set the switch to the 'STOP' position.

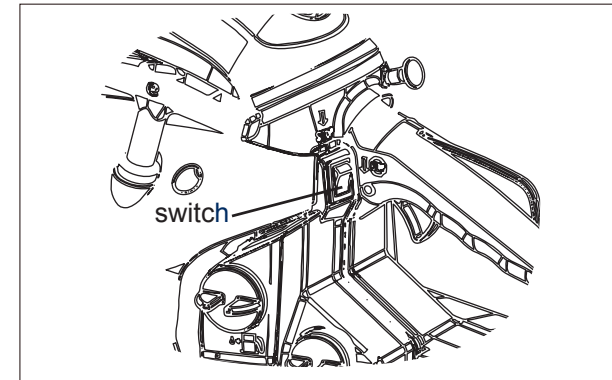

IMPORTANT! Do not put the chainsaw on the ground while it is still running. For additional safety, switch the chainsaw off when not in use or between cuts. In the event that the ignition switch will not stop the saw, pull the choke control out and engage the chain brake to stop the engine. Call the service centre.

NOTE: When you have finished using the saw, always relieve the tank pressure by loosening, then retightening, both tank caps. Allow the engine to cool before storing.

STEP 5 - SAWING



WARNING! Before proceeding with your job, read the 'Safety instructions' section. It is recommended to first practice sawing easy logs. This also helps you get accustomed to your unit. Always follow the safety regulations. The chainsaw must only be used for cutting wood. It is forbidden to cut other types of material. Vibrations and kickback will vary with materials other than wood, and the requirements of the safety regulations will not be met. **DO NOT** use the chainsaw as a lever for lifting, moving or splitting objects.

DO NOT lock it over fixed stands. It is strictly forbidden to attach any accessories to this product other than those supplied by the manufacturer.

It is not necessary to force the saw into the cut. Apply only light pressure while running the engine at full throttle. If the chainsaw gets caught in the cut, do not attempt to force it out, but use a wedge or a lever to enlarge the cut, freeing the saw.

STEP 6 - FELLING A TREE



WARNING!

You should have received training from a suitable person before attempting to fell a tree.

When you fell a tree, be sure to warn anyone in close proximity of the danger.

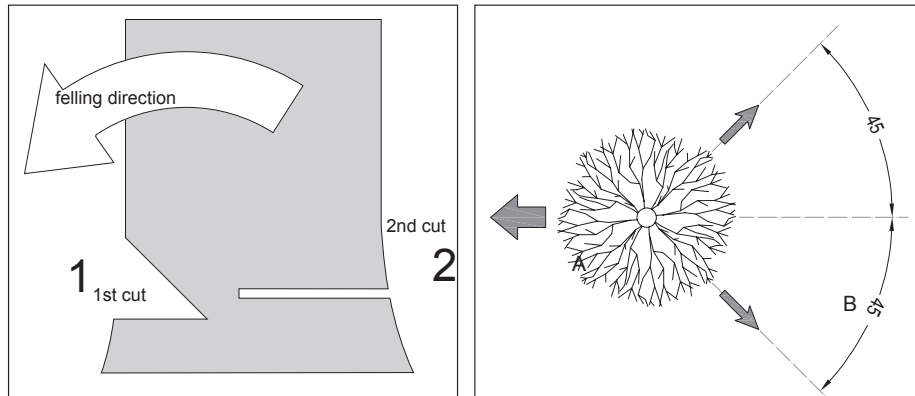

1. When deciding the felling direction, consider the wind, lean of the tree, location of heavy branches, ease of job after felling, and other factors.
2. While cleaning the area around the tree, arrange a good foothold and retreat path.
3. Make a notch cut one-third of the way into the tree on the felling side.

4. Make a felling cut from the opposite side of the notch and at a level slightly higher than the bottom of the notch.
5. Escape path: First, clear the tree base and work area of interfering limbs and brush, and clean its lower portion with an axe. Then, establish two paths of escape (B) and remove all obstacles. These paths should be generally opposite to the planned direction of the fall of the tree (A) and at about a 45° angle. Place all tools and equipment a safe distance away from the tree, but not on the escape paths.

STEP 7 - BUCKING AND LIMBING



WARNING!

- Always ensure a stable foothold; do not stand on the log.
- Be alert to the rolling over of a cut log, especially when working on a slope, and stand on the uphill side of the log.
- Follow the instructions in 'Safety Instructions' to avoid kickback from the saw.
- Before starting work, check the direction of the bending force inside the log to be cut. Always finish cutting from the opposite side of the bending direction, to prevent the chain bar from being trapped in the cut. Follow this guidance:
 - DO NOT use an unstable foothold or ladder.
 - DO NOT overreach.
 - DO NOT cut above shoulder height.
 - Always use both hands to grip the saw.

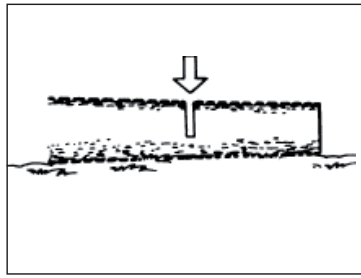

Fig. A

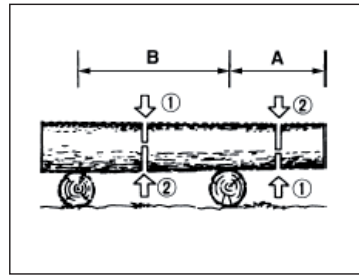

Fig. B

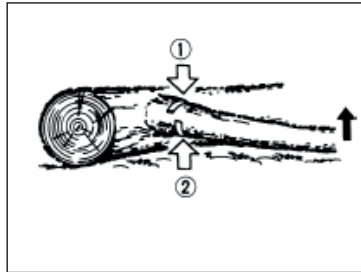

Fig. C

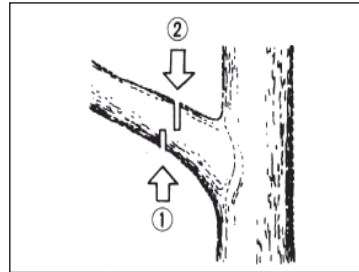

Fig. D

A log lying on the ground (Fig. A)

Saw down halfway, then roll the log over and cut from the opposite side.

A log supported off the ground (Fig. B)

In area A, saw up from the bottom one third and finish by sawing down from the top. In area B, saw down from the top one third and finish by sawing up from the bottom.

Cutting the limb of a fallen tree (Fig. C)

First check to which side the limb is bent. Then make an initial cut from the bend side and finish by sawing from the opposite side.



WARNING! Be alert to the spring back of a cut limb. Pruning of a standing tree (Fig. D). Cut up from the bottom, finish down from the top.

MAINTENANCE AND STORAGE LIST OF VULNERABLE PARTS

Description	Models or specifications
Spark plug	L8RTF
Guide bar	160SDEA041
Saw chain	91P057X

MAINTENANCE AFTER EACH USE



WARNING!

Before cleaning, inspecting or repairing your unit, make sure that the engine has stopped and is cool. Disconnect the spark plug to prevent accidental starting.

1. Air filter

Dust on the air filter surface can be removed by detaching the air filter cover (A), removing the filter and tapping a corner of the filter cover (B) against a hard surface. To clean dirt in the meshes, brush in petrol. When using compressed air, blow from the inside.

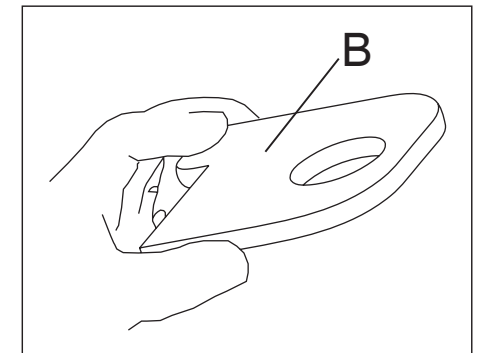
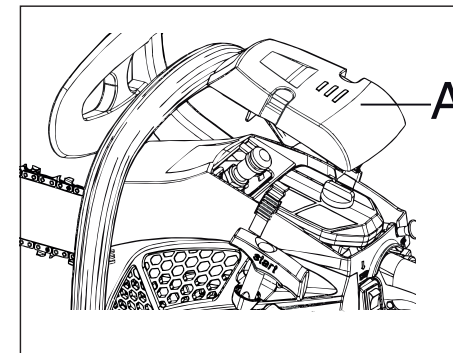

2. Oiling port

Detach the chain bar and check the oiling port (A) for clogging.

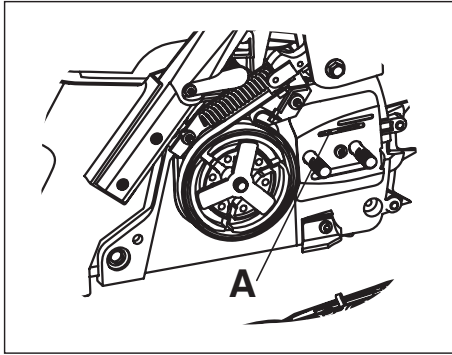

3. Chain bar

When the chain bar is dismounted, remove sawdust from the bar groove and the oiling port. Grease the nose sprocket through the grease port on the tip of the bar.

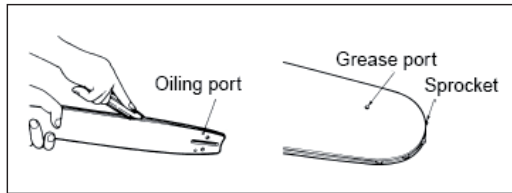

4. To ensure that the saw's engine retains its power, the spark plug must be clean and have the correct electrode gap (0.6mm). The spark plug (B) must be cleaned or replaced after every 20 hours of service.

- Set the O/I switch to Stop (0).
- Remove the top air filter cover.
- Disconnect the ignition cable from the spark plug by pulling and twisting it simultaneously.
- Remove the spark plug using the supplied spark plug wrench. **DO NOT USE ANY OTHER TOOLS.**
- Clean the spark plug with a copper wire brush and refit it or fit a new spark plug. Then replace the top cover.

5. Others

Check for fuel leakage, loose fastenings and any damage to major parts, especially handle joints, chain bar mounting and silencer. If any defects are found, make sure to have them repaired before operating the unit again.

HOW TO REPLACE THE SAW

- Pull the chain brake back and ensure that it has been released (the chain cover can only be removed with the chain brake disengaged).

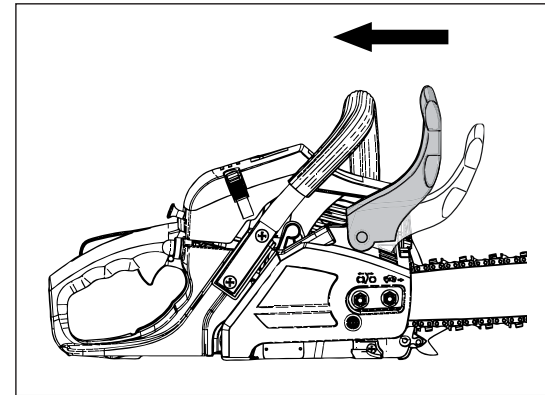

- Loosen the chain cover tightening wheel and the chain cover.

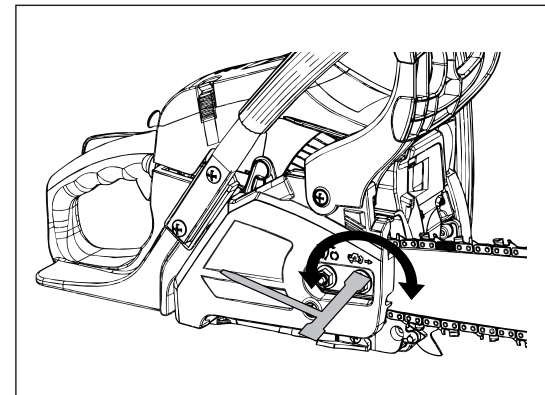

- Fit the chain around the bar ensuring that the direction of the chain is as depicted in the picture on the bar. Fit the chain on the sprocket. Adjust the position of chain tensioner so the tensioner pin locates in the hole (A) on the bar.

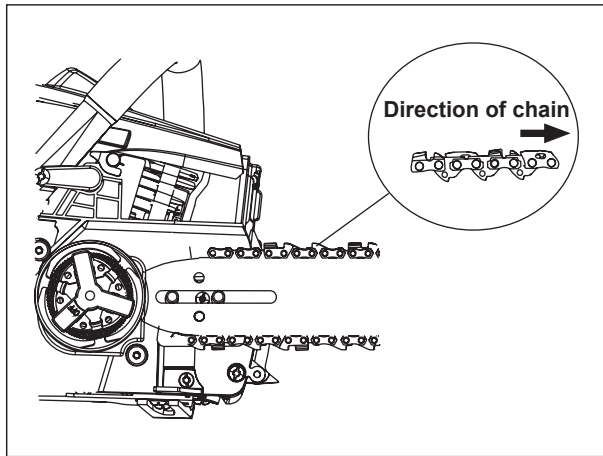

- Adjust the tension to ensure that there is not too much slack in the chain. Make sure the tensioner pin (B) is located in the assembly hole (A) on the bar. Pay attention to the correct direction of the saw chain. Compare with the picture near the chain sprocket and the picture on the bar.

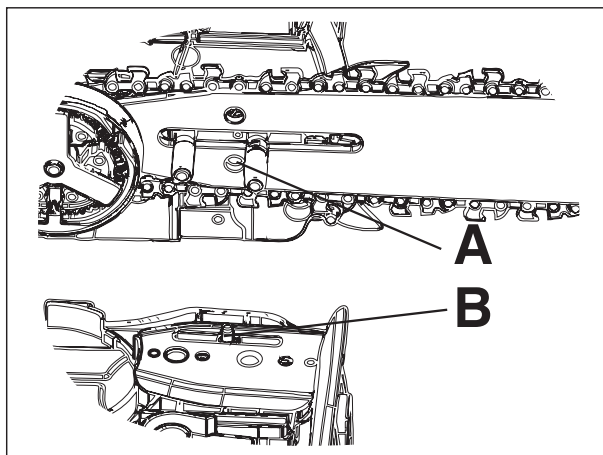

- Fit the chain cover to the power unit and fasten the nuts to the chainsaw, ensure these are fastened as tight as possible using your fingers only.
- While holding up the tip of the bar, adjust the chain tension by turning the adjustment wheel until the chain engages in the bar channel. When tensioned correctly, it should be possible to pull one full chain link free of the bar channel with ease.
- Tighten the wheel as secure as you can using your fingers. Then check the chain for smooth rotation and proper tension while moving it by hand. If necessary, loosen the chain cover.
- Tighten the tensioner wheel.

NOTE: A new chain will expand its length during the first period of use. Check and re-adjust the tension frequently, as a loose chain can easily derail or cause rapid wear of itself and the chain bar.



CAUTION! If the saw chain is TOO LOOSE or TOO TIGHT the V-drive wheel, chain bar, chain and crank shaft bearing will suffer premature wear. Below Fig. shows the correct tension A (when cold) and tension B (when warm). Fig. C shows a chain that is too loose.

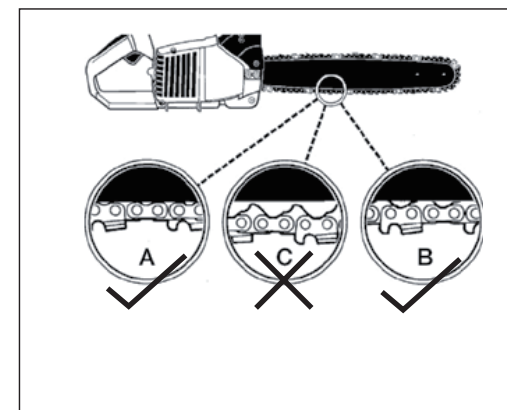

PERIODICAL SERVICE POINTS

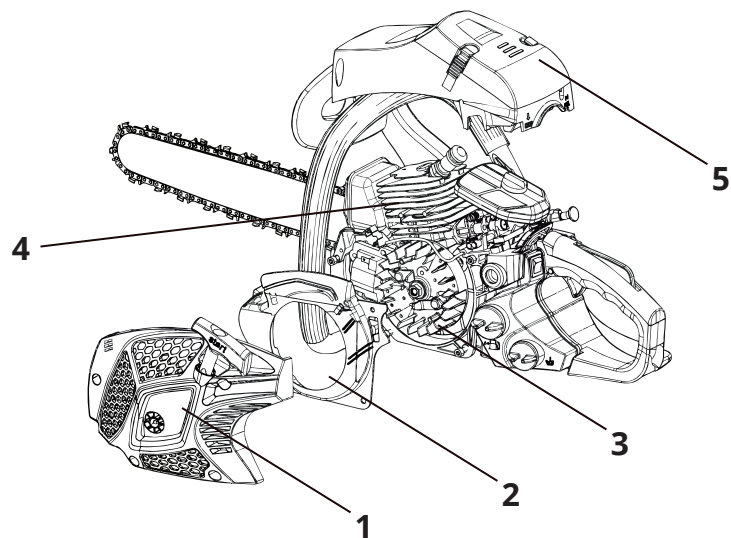

1. Start assembly
2. Fan cover
3. Fan
4. Cylinder fins
5. Engine cover

Air cooling system

Dust clogging around the cooling system and the cylinder fins will cause overheating of the engine. Periodically check and clean the cooling system and the cylinder fins with a brush after removing the cylinder cover, the air cleaner and the recoil case. When installing the cylinder cover and the cooling system, make sure that switch wires and grommets are positioned correctly in place.

NOTE: Be sure to unblock the air intake hole.

MAINTENANCE OF THE SAW CHAIN AND CHAIN BAR

The cutters need to be sharpened when:

1. Sawdust becomes powder-like.
2. Cutting requires extra force.
3. The chainsaw does not cut straight and clean.
4. Vibration increases.
5. Fuel consumption increases.

NOTE: It is very important for smooth and safe operation to always keep the cutters sharp.

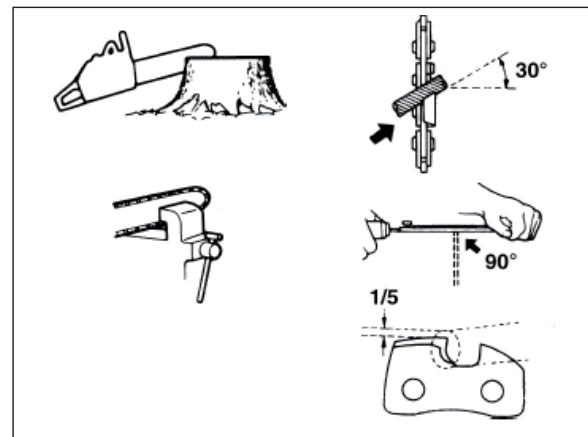

Cutter setting guidance



WARNING! Be sure to wear safety gloves.

Before filing:

1. Make sure the saw chain is held securely.
2. Make sure the engine is stopped.
3. Use a round file with the proper size for your chain.

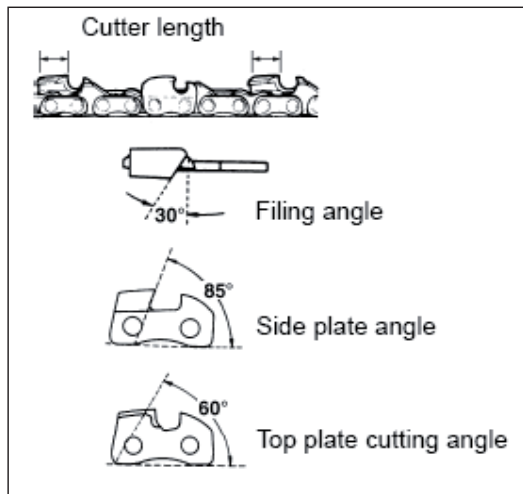
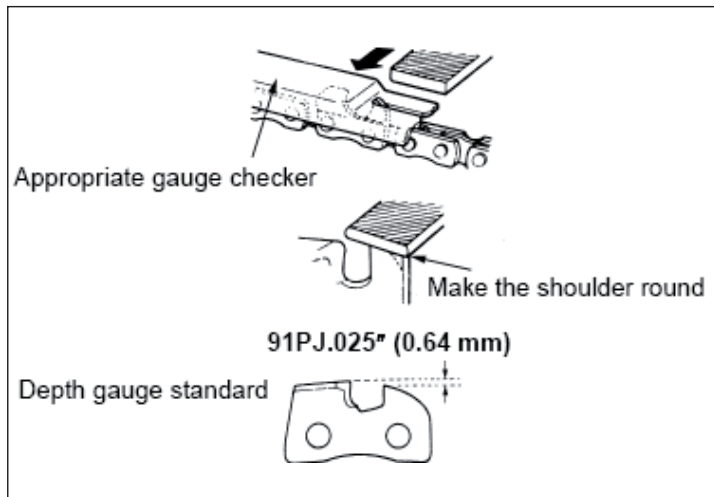

NOTE: Chain type: 91PJ File size: 5/32 in (4mm). Place your file on the cutter and push straight forward. Position the file as illustrated.

After each cutter has been set, check the depth gauge and file it to the proper level as illustrated. Make sure each cutter has the same length and angle as illustrated.

Chain Bar

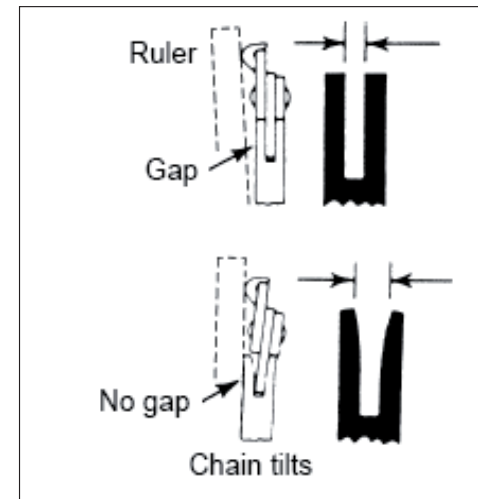

1. Reverse the bar occasionally to prevent partial wear.
2. The bar rail should always have parallel internal faces (see diagram). Check for wear of the bar rail. Apply a ruler to the bar and the outside of a cutter. If a gap is observed between them, the rail is normal. Otherwise, the bar rail is worn. Such a bar needs to be corrected or replaced.

TECHNICAL DATA

Model	CS4100A-5
Engine displacement	41cm ³
Engine	1.4kW
Bar length	37.5cm
Chain gauge	(0.050"), 1.27mm
Idling speed	3100±300/min
Maximum speed with cutting equipment	11000/min
Maximum chain speed	21m/s
Fuel tank capacity	260ml
Oil tank capacity	210ml
Anti-vibration function	Yes
Chain wheel teeth	6 Teeth * 9.525mm
Chain brake	Yes
Clutch	Yes
Automatic chain lubrication	Yes
Net weight without chain and chain bar	4.5kg
Fuel consumption (specific)	702g /kWh
LpA sound pressure level	99 dB(A) K=3 dB(A)
LWA sound power level	114 dB(A)
Vibration ahv (front handle) max.	6.5 m/s ² K=1.5 m/s ²
Vibration ahv (rear handle) max.	6 m/s ² K=1.5 m/s ²
Spark plug	L8RTF
Guide bar	160SDEA041
Saw chain	91P057X

The sound intensity level for the operator may exceed 80 dB(A) and ear protection measures are necessary. The declared vibration value has been measured in accordance with a standard test method and may be used for comparing one product with another. The declared vibration value may also be used in a preliminary assessment of exposure.



WARNING! This tool may cause Hand-Arm Vibration Syndrome (HAVS) if its use is not adequately monitored and managed.

Preventative measures include, among others, regular maintenance and care of the product and cutting attachments, keeping hands warm and periodical breaks, as well as proper planning of work processes.

TROUBLESHOOTING



CAUTION!

Always switch off the engine and pull the ignition cable before starting any inspection or adjustment work.

If, after making an adjustment or repair to the engine, you let it run for a few minutes, remember that the exhaust and other parts will get hot. Do not touch parts that emanate heat, as these may burn you.

The following table provides solutions to common problems encountered with the chainsaw.

Fault	Possible Cause	Solution
Unit won't start or starts but will not run	<ol style="list-style-type: none"> 1. Incorrect starting procedures 2. Incorrect carburetor mixture adjustment setting 3. Fouled spark plug 4. Fuel filter blocked 5. Chain brake is engaged 	<ol style="list-style-type: none"> 1. Follow instructions in the user guide or refer to the starting procedure check list on page 18 2. Have carburetor adjusted by an authorised service centre 3. Clean/gap or replace plug 4. Replace fuel filter 5. Pull chain brake in disengage position
Unit starts but engine has low power	<ol style="list-style-type: none"> 1. Incorrect lever position on choke 2. Dirty air filter 3. Incorrect carburetor mixture adjustment setting 	<ol style="list-style-type: none"> 1. Move to RUN position 2. Remove, clean and reinstall filter 3. Have carburetor adjusted by an authorised service centre

Engine hesitates	1. Incorrect carburetor mixture adjustment setting	1. Have carburetor adjusted by an authorised service centre
No power under load	1. Incorrectly gapped spark plug	1. Clean/gap or replace plug
Runs erratically	1. Incorrect carburetor mixture adjustment setting	1. Have carburetor adjusted by an authorised service centre
Smokes excessively	1. Incorrect fuel mixture	1. Use properly mixed fuel (40:1 mix)
Poor performance when operated	<ol style="list-style-type: none"> 1. Blunt chain 2. Loose chain 	<ol style="list-style-type: none"> 1. Sharpen or replace the chain 2. Tension the chain
Engine dies	<ol style="list-style-type: none"> 1. Empty petrol tank 2. Fuel filter in the wrong position in the tank 	<ol style="list-style-type: none"> 1. Fill up the petrol tank 2. Completely fill the petrol tank or reposition the fuel filter in the petrol tank
Insufficient chain lubrication (the cutter rail and chain get hot)	<ol style="list-style-type: none"> 1. Empty oil tank for the chain 2. Oil lubrication opening blocked 	<ol style="list-style-type: none"> 1. Top up the oil tank for the chain 2. Clean the oil lubrication hole in the cutter bar Clean the groove in the cutter bar

DISPOSAL

The chainsaw and its accessories are made of various recyclable materials. Dispose of the chainsaw in accordance with your local recycling regulations.

GETTING HELP

Our dedicated UK based customer helpline is open 7 days a week to assist you with assembly, parts queries and technical support. We are open during office hours but you can always send an email via **support@gardenservicecentre.co.uk**. Our experts are here to get you back enjoying your garden in no time.

For useful assembly, starting and maintenance videos, and for ordering spares, please visit **www.gardenservicecentre.co.uk**

Calling our service does not affect your statutory rights

UK/Ireland 01904 727509

Monday to Friday: 9am – 5pm. Saturday & Sunday: 11am – 4pm

www.gardenservicecentre.co.uk

email: support@gardenservicecentre.co.uk

WARRANTY

Any claim under this warranty must be made within 12 months of the date of purchase. To make a claim under the warranty, take the product (with proof of purchase) to your local store.

HHGL Limited bears reasonable, direct expenses of claiming under the warranty.

You may submit details and proof to our store for consideration.

The warranty covers manufacturer defects in materials, workmanship and finish under normal use.

This warranty is provided in addition to other rights and remedies you may have under law: our goods come with guarantees which cannot be excluded under the UK Consumer Rights Act 2015.

You are entitled to a replacement or refund for a major failure, and to compensation for other reasonably foreseeable loss or damage. You are also entitled to have the goods repaired or replaced if the goods fail to be of acceptable quality and the failure does not amount to a major failure.

The warranty excludes damage resulting from product misuse or product neglect. The warranty covers domestic use only and does not apply to commercial applications.

This warranty is given by:

HHGL Limited, MK9 1BA

HHGL (ROI) Limited, D02 X576