

# Challenge Xtreme 26cc Petrol Grass Trimmer

Assembly Manual

CDB26

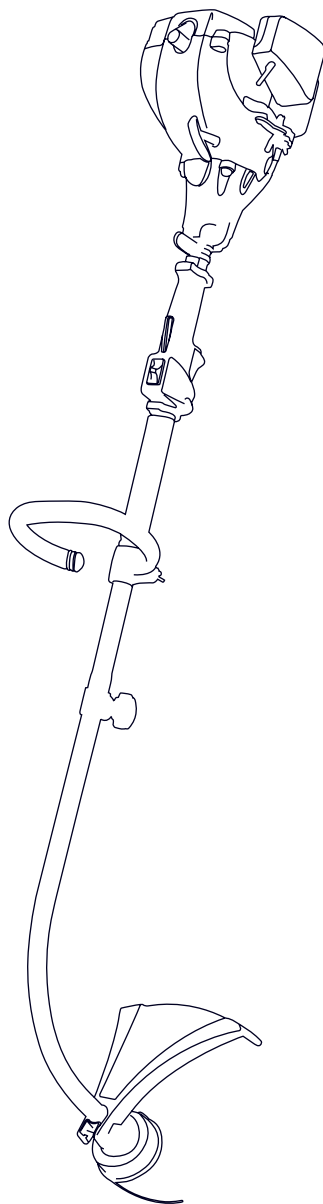

Technical Support & Parts

**0845 450 5299**

[www.gardenservicecentre.co.uk](http://www.gardenservicecentre.co.uk)



Scan to watch  
our new  
instruction  
videos!

**challenge**  
**xtreme**

**Important** - Please read these instructions fully before starting assembly

These instructions contain important information that will help you get the best from your grass trimmer, ensuring it is assembled correctly and safely.

# Contents

Safety Information.....	3
Warning Symbols.....	3
General Safety.....	3
Personal Safety.....	3
In the Box.....	4
Parts.....	4
Tools.....	4
Assembly.....	5
Preparing to assemble the grass trimmer.....	5
Step 1.....	5
Step 2.....	6
Step 3.....	6
Step 4.....	7
Getting Help.....	7

## Safety Information

Important - Please read these instructions fully before starting assembly

### Warning Symbols

The following warning symbols appear throughout this assembly manual and indicate the appropriate safety measures you should take when assembling and operating the grass trimmer.



This symbol indicates there is a danger of serious personal injury or death if you do not observe the warning.



This symbol indicates that there is a danger of damaging your hands if you do not wear thick, protective gloves.

### General Safety



#### WARNING!

- Keep this assembly manual in a safe place following assembly for reference at a later date.
- Always ensure anyone intending to operate this grass trimmer is fully conversant with the contents of this assembly manual prior to assembling, maintaining or operating the grass trimmer.
- Perform assembly operations as described in this manual. Failure to observe this warning may lead to serious injury, death, or damage to the grass trimmer.



- Always take care when removing the packaging to prevent damage to you or to the grass trimmer.

**IMPORTANT!** Before assembling the grass trimmer, check all the parts indicated in the manual are in the box. Inspect all the parts for signs of damage. Do not assemble the grass trimmer if you observe any damaged components.

### Personal Safety



#### WARNING!

- Only operate the grass trimmer if you are wearing the correct Personal Protective Equipment (PPE) as described in the following warnings.



- Always wear suitable gloves when operating grass trimmer to protect your hands from flying debris and/or sharp objects.

# In the Box

Parts		Tools	
<b>A</b> Engine body with upper shaft	<b>C</b> Front handle+bolts	<b>1</b> Plug wrench & philips screwdriver 1pc	<b>2</b> Mixing bottle
<b>B</b> Trimmer head with lower shaft	<b>D</b> Safety guard+bolt		
	<b>E</b> Safety strap		

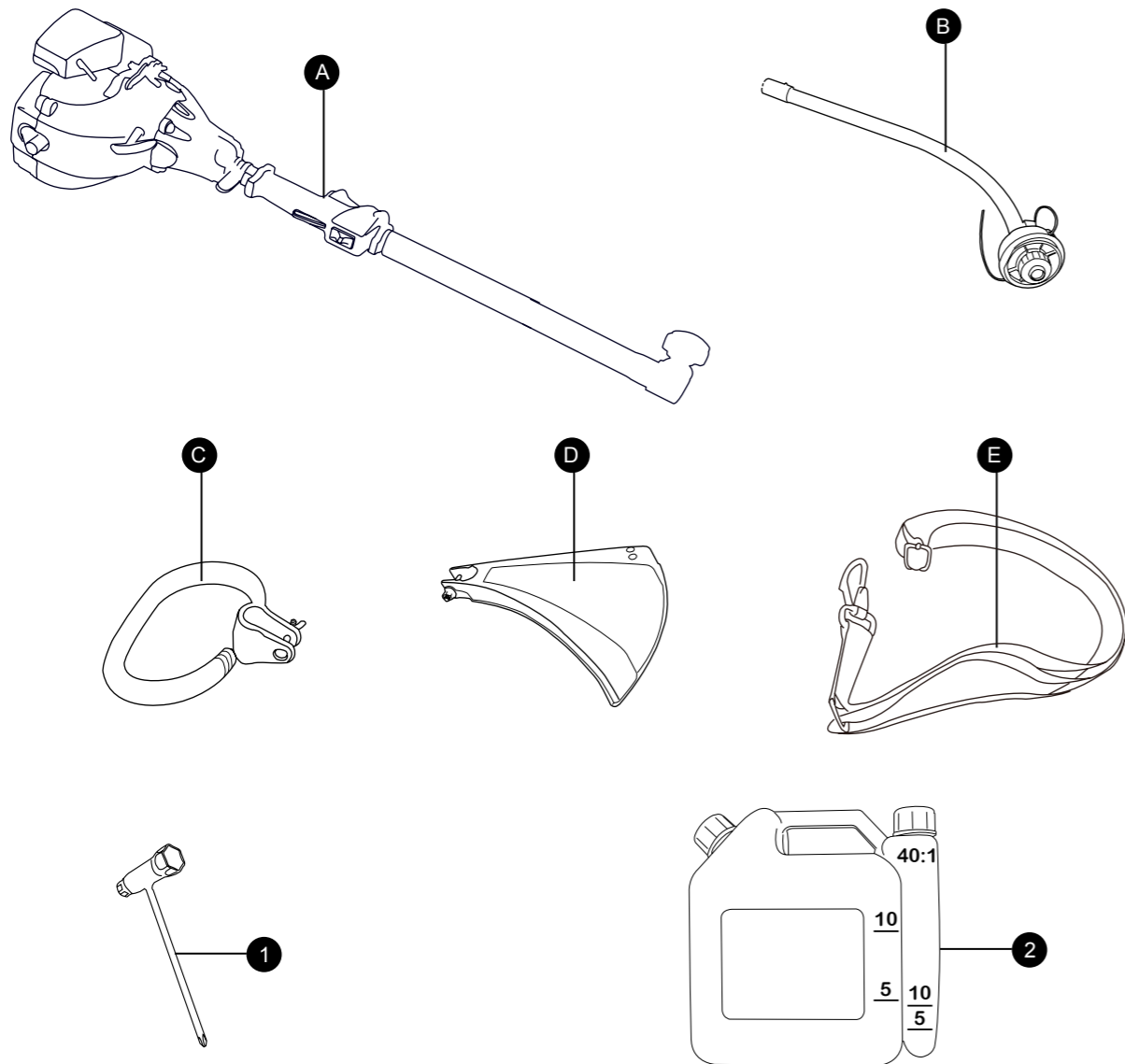

You will also need:

- 2 stroke oil
- Unleaded fuel
- Funnel

If there are any parts missing, please call the customer helpline on **0845 450 5299**

# Assembly

## Preparing to assemble the grass trimmer



### WARNING!

- Always take care when removing the packaging to prevent damage to you or to the grass trimmer.



### IMPORTANT!

- Before assembling the grass trimmer, check all the parts indicated in the manual are in the box. Inspect all the parts for signs of damage. Do not assemble the grass trimmer if you observe any damaged components.

1. Remove all parts of the grass trimmer from the box and carefully remove all packaging. Take care not to lose any instructions which may be attached to the tool, these provide important information which will be required while assembling the grass trimmer.
2. Keep all packaging until the grass trimmer is fully assembled and has been operated successfully.

## Step 1

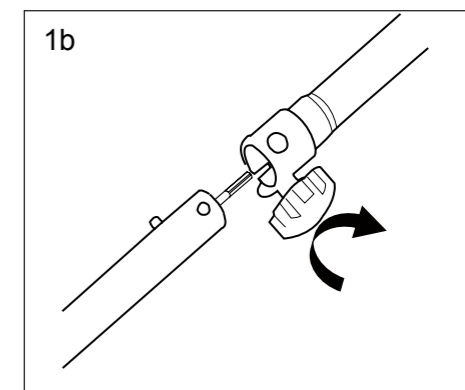
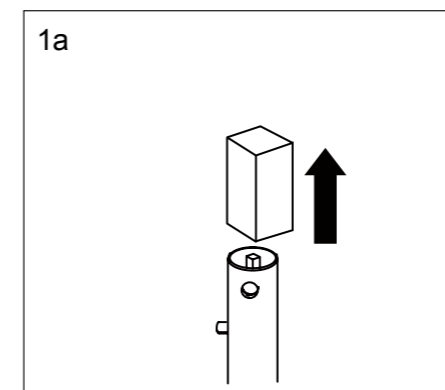

Always recycle the packaging in accordance with local recycling schemes.

1a Take off the protection cap from the lower shaft. Push in the button located on the lower shaft.

1b Align the button with the guide recess on the upper shaft and slide the two shafts together. Rotate the drive shaft until the button locks into the positioning hole. Tighten the knob on the coupler, securing the two shafts together.

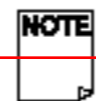

**Note!** If you have difficulty in assembling of the lower drive shaft –then rotate the cutting head slightly ,this will then align the drive shaft for assembly.

# Assembly

## Step 2

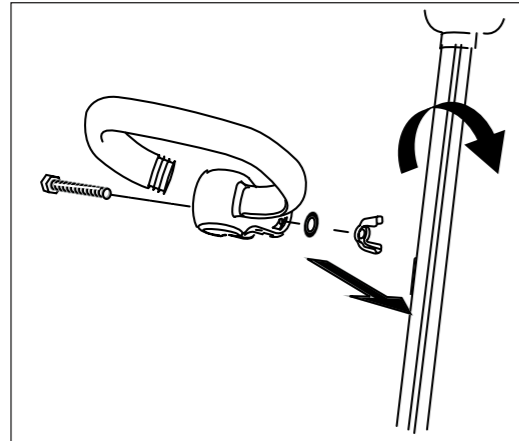

1. Take the front handle and push it onto the upper shaft.
2. Align the bolt holes and push the long bolt through the handle side.
3. Place short bolt through opposite side of clamp. Install flat washer, lock washers and hex nuts to hold the assembly in place.
4. After assembly is complete, adjust the position of the handle for best balance and comfort.
5. Tighten the long bolt first and then the short bolt.

## Step 3

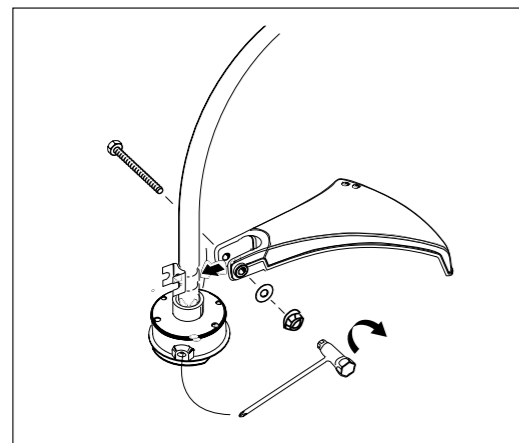

Attach the curved shaft grass guard by snapping the guard around the shaft so it locates with the bracket. Fix in place by inserting the bolts through the guard and bracket and tighten up.

# Assembly

## Step 4

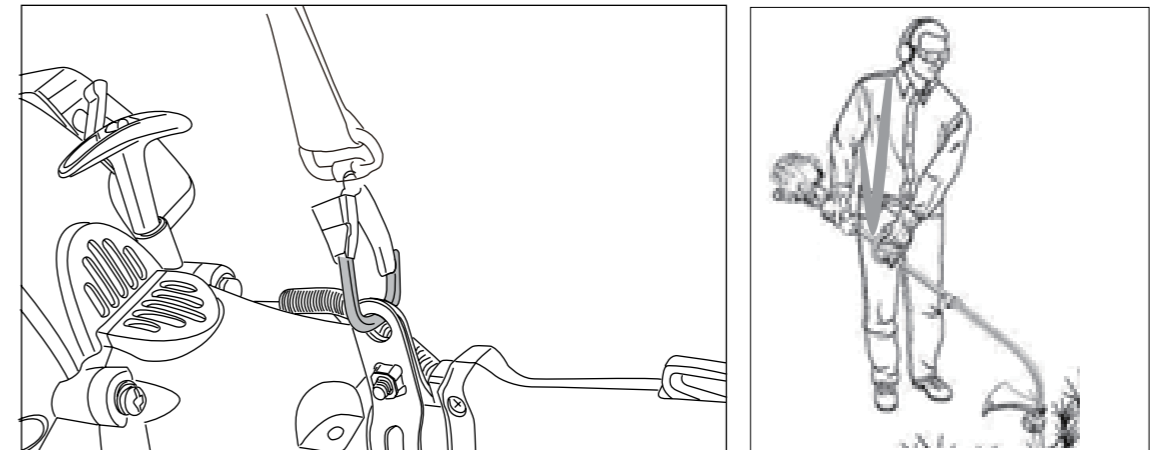

Assemble the safety strap.

# STOP!

Do not start the engine before reading page 7-9 of the Operation and Maintenance Manual.

## Getting Help

Customer Helpline **0845 450 5299**

Our dedicated UK based customer helpline is open 7 days a week to assist you with assembly, parts queries and technical support. We are open during office hours but you can always send an email via [support@gardenservicecentre.co.uk](mailto:support@gardenservicecentre.co.uk). Our experts are here to get you back enjoying your garden in no time.

For useful assembly, starting and maintenance videos and ordering spares please visit [www.gardenservicecentre.co.uk](http://www.gardenservicecentre.co.uk).

Calling our service does not affect your statutory rights

UK/Ireland **0845 450 5299**  
Monday to Friday 9am – 5pm Saturday & Sunday 11am – 4pm  
[www.gardenservicecentre.co.uk](http://www.gardenservicecentre.co.uk)  
email: [support@gardenservicecentre.co.uk](mailto:support@gardenservicecentre.co.uk)

# Challenge Xtreme 26cc Petrol Grass Trimmer

Operation and Maintenance Manual

CDB26

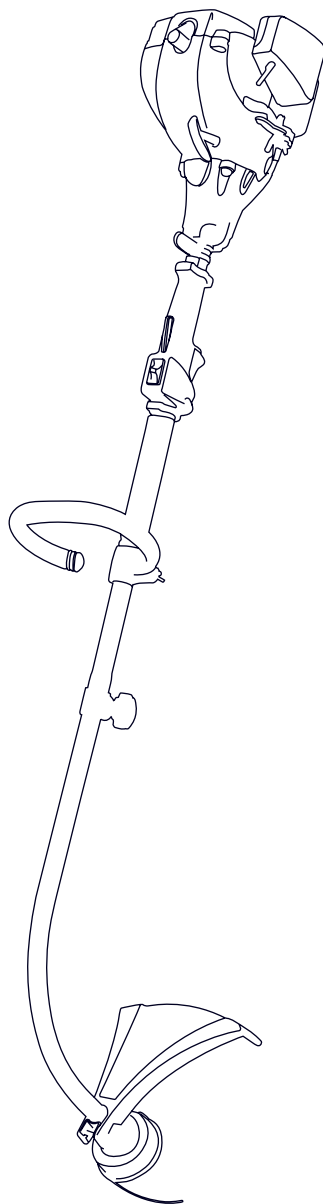

Technical Support & Parts

**0845 450 5299**

[www.gardenservicecentre.co.uk](http://www.gardenservicecentre.co.uk)



Scan to watch  
our new  
instruction  
videos!

*challenge*  
**xtreme**

**Important** - Please read these instructions fully before starting assembly

These instructions contain important information that will help you get the best from your grass trimmer, ensuring it is assembled correctly and safely.

# Contents

Safety Information.....	3
Warning Symbols.....	3
General Safety.....	4
Personal Safety.....	4
Operational Safety.....	4
Maintenance and Storage Safety.....	6
Preparing to Operate the Grass Trimmer.....	7
Step 1 - Filling with Engine Fuel.....	7
Operating the Grass Trimmer.....	8
Step 1 - Removing the blade protector.....	8
Step 2 - Starting the Engine.....	8
Step 3 - Trimming.....	9
Step 4 - Extending spool line while trimming.....	10
How to Replace the Spool/Spool Line.....	11
Step 1 - Removing the spool.....	11
Step 2 - Replacing the spool line in the spool.....	11
Step 3 - Inserting the line spool.....	12
Cleaning the Air Filter.....	13
Replacing the Spark Plug.....	13
Storing the Grass Trimmer.....	14
Step 1 - Storing the Grass Trimmer for Short Periods.....	14
Step 2 - Storing the Grass Trimmer for Extended Periods.....	14
Maintenance.....	14
Maintenance Schedule.....	14
Troubleshooting.....	15
Technical Data.....	16
Disposal.....	16
Getting Help.....	16
Guarantee.....	17
Declaration of Conformity.....	18

# Safety Information

Important - Please read these instructions fully before operating or maintaining

## Warning Symbols

The following warning symbols appear through this manual and indicate the appropriate safety measures you should take when operating and maintaining the grass trimmer.



**Wear protective glasses, hearing protection, and a safety helmet.**



**Wear protective gloves.**



**Wear safety shoes.**



**Read the instructions for use prior to operating the machine.**



**When starting and working, keep the filament head away from foreign materials.**



**When working, maintain a safety distance of 15 m from other people and from animals.**



**Do not use metal cutting blades!**



**Only the filament trimmer may be used as a tool.**



**Maximum permitted rotational speed of the cutting tool.**



**Warning! Hot surface, do not touch.**

## Safety Information

Important - Please read these instructions fully before operating or maintaining

### General Safety



#### WARNING!

- Keep this operating and maintenance manual in a safe place for reference at a later date.
- Read the instructions carefully. Be familiar with the controls and the proper use of the equipment.
- Never allow children or people unfamiliar with these instructions to use the grass trimmer. Local regulations can restrict the age of the operator.
- Never trim while people, especially children, or pets are nearby. Keep in mind that the operator or user is responsible for accidents or hazards occurring to other people or their property.
- This appliance is not intended for use by persons (including children) with reduced physical, sensory or mental capabilities, or lack of experience and knowledge, unless they have been given supervision or instruction concerning use of the appliance by a person responsible for their safety.
- Do not touch rotating spool.

### Personal Safety



- Do not allow children or untrained individuals to use this unit.
- Never start or run the engine in an enclosed or poorly ventilated area, breathing exhaust fumes can kill.
- Clear the work area before each use. Remove all objects such as rocks, broken glass, nails, wire, or other such debris which can be thrown or become entangled in the cutting line.
- Wear safety glasses or goggles when operating this unit.
- Wear heavy, long trousers, boots, and gloves. Do not wear loose fitting clothing, shorts, or go barefoot. Do not wear jewellery of any kind.

### Operation



- Never operate this unit on the operator's left side.
- Secure long hair above shoulder level to prevent entanglement in moving parts.
- Keep all bystanders, children, and pets at least 15 m (50 ft.) away.
- Do not operate this unit when you are tired, ill, or under the influence of alcohol, drugs, or medication.
- Do not operate it in poor lighting.
- Keep firm footing. Do not overreach. Overreaching can result in loss of balance or exposure to hot surfaces.

## Safety Information

Important - Please read these instructions fully before operating or maintaining

### Operation (continued)

- Keep all parts of your body away from any moving parts.
- To avoid hot surfaces, never operate the unit with the bottom of the engine above waist level.
- Do not touch area around the exhaust or cylinder of the unit, these parts get hot during operation.
- Always stop the engine and remove the spark plug wire before making any adjustments or repairs except for carburetor adjustments.
- Inspect the unit for loose fasteners, fuel leaks, etc. before each use. Replace any damaged parts before use.
- The string head will rotate during carburetor adjustments and engine starting.
- It has been reported that vibrations from hand-held tools may contribute to a condition called Raynaud's Syndrome in certain individuals. Symptoms may include tingling, numbness and blanching of the fingers, usually apparent upon exposure to cold. Hereditary factors, exposure to cold and dampness, diet, smoking and work practices are all thought to contribute to the development of these symptoms. It is presently unknown what, if any, vibrations or extent of exposure may contribute to the condition. There are measures that can be taken by the operator to possibly reduce the effects of vibration:
  - a) Keep your body warm in cold weather. When operating the unit wear gloves to keep the hands and wrists warm. It is reported that cold weather is a major factor contributing to Raynaud's Syndrome.
  - b) After each period of operation, exercise to increase blood circulation.
  - c) Take frequent work breaks. Limit the amount of exposure per day.
  - d) Keep the tool well maintained, fasteners tightened and worn parts replaced.If you experience any of the symptoms of this condition, immediately discontinue use and see your Doctor about these symptoms.
- Mix and store fuel in a container approved for petrol clearly identified as 2-Stroke.
- Mix fuel outdoors where there are no sparks or flames. Wipe up any fuel spillage. Move 9 m (30 ft.) away from refueling site before starting engine.
- Stop the engine and allow to cool before refueling or storing the unit.
- Allow the engine to cool; empty the fuel tank and secure the unit from moving before transporting in a vehicle.
- Replace string head if cracked, chipped, or damaged in any way. Be sure the string head is properly installed and securely fastened. Failure to do so can cause serious injury.
- Make sure all guards, straps, and handles are properly and securely attached.
- Use only the manufacturer's replacement string in the cutting head. Do not use any other cutting attachment. To install any other brand of cutting head to this string trimmer may result in serious personal injury.
- Never operate unit without the grass guard in place and in good condition.

# Safety Information

Important - Please read these instructions fully before operating or maintaining

## Operation (continued)

-Maintain a firm grip on both handles while trimming. Keep string head below waist level. Never cut with the string head located over 76 cm (30 in.) above the ground.

### Intended use:

This machine is designed to use as grass trimmer for trimming grass and light foliage - **for non-commercial use only!**

### Non-intended use:

This machine is not designed for trimming hedges or the or any other job task where by the machine has to be raised over a 30 degree angle.

### Residual risks:

The machine uses a rotating cutting tool. Through this rotational motion debris can be thrown from the cutting head of the unit (eg stones and sticks).

## Maintenance and Storage Safety



### WARNING!

- Keep all nuts, bolts and screws tight to be sure the equipment is in safe working condition;
- Never store the equipment with petrol in the tank inside a building where fumes can reach an open flame or spark;
- Allow the engine to cool before storing in any enclosure;
- To reduce the fire hazard, keep the engine, battery compartment free of grass, leaves, or excessive grease;
- Replace worn or damaged parts for safety;
- If the fuel tank has to be drained, this should be done outdoors.

# Preparing to Operate the Grass Trimmer

## Step 1 - Filling with Engine Fuel



**WARNING!** Always switch engine off before fueling. Never add fuel to a machine with a running or hot engine. Move at least 30ft.(9 m) from refueling site before starting engine. Do not smoke!



**IMPORTANT!** Keep bottle flat while filling and use funnel.

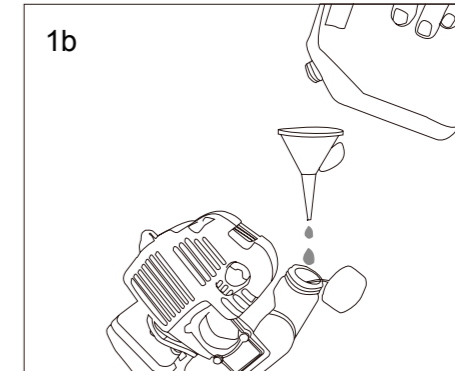
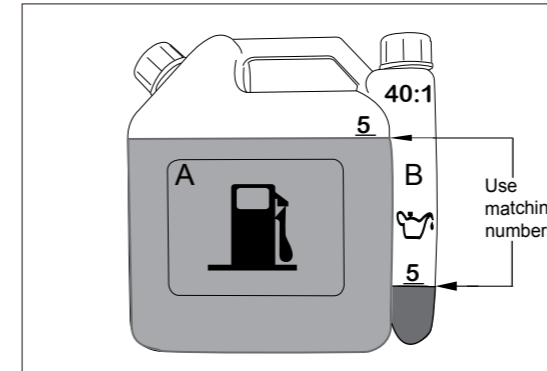

This product is powered by a 2-Stroke engine and requires pre-mixing of petrol and 2-stroke oil. Mix a high quality 2-Stroke engine oil according JASO FC classic. Do not use automotive oil or 2-stroke outboard oil. DO NOT mix quantities larger than usable in a 30 day period.

### 1a. FUEL MIXTURE: 1 Litre (1000 ml) petrol: 25cc (25 ml) 2 Stroke engine oil (40:1 ratio)

Using a funnel and keeping the bottle level, pour the fuel in the left hand side ('A') up to the required level eg 2.5 or 5 then fill the right hand side ('B') up to the same corresponding mark with oil. Please ensure that no fuel has leaked into B prior to pouring in oil. Shake vigorously to mix the two products prior to pouring into the tank of grass trimmer.



**NOTE!** Use 5 for 500ml fuel mixture and 2.5 for 250ml fuel mixture.

### 1b. FILLING TANK

Clean surface around fuel cap to prevent contamination. Loosen fuel cap slowly. Rest the cap on a clean surface. Carefully pour fuel into the tank. Avoid spillage. Prior to replacing the fuel cap, clean and inspect the seal located inside the fuel cap. Immediately replace fuel cap and hand tighten. Wipe up any fuel spillage.



**NOTE!** It is normal for smoke to be emitted from a new engine after first use.



# Operating the Grass Trimmer

## Step 1 - Removing the blade protector

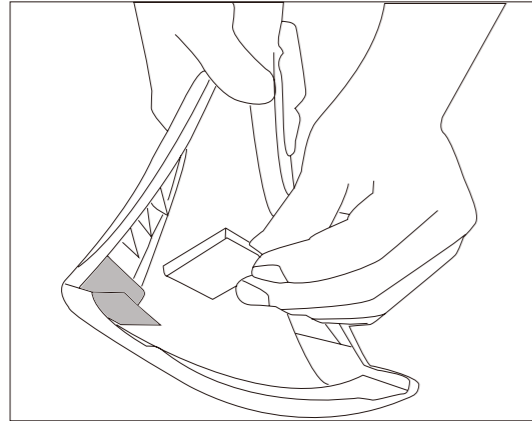

Remove the blade protector.

## Step 2 - Starting the Engine

	Cold	Hot
1 Set START/STOP switch to START position	1	1
2 Press primer bulb 7-10 times		
3 FULL CHOKE position		
4 Pull cord so that motor turns over, (the engine may start)		
5 HALF CHOKE position Choke will automatically return to 'Run' position when Throttle is pressed		
6 Pull cord until motor runs		
7 RUN position		
8 Pull cord until motor runs		

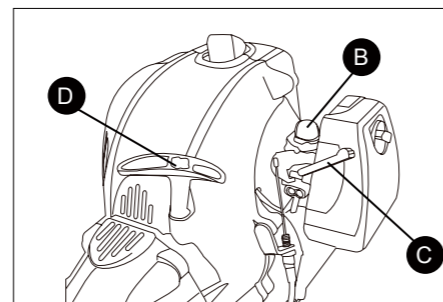
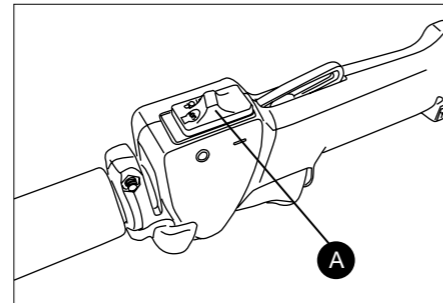

### 2a To start a cold engine

- 1) Lay the machine on a flat surface free of growth, resting it on the motor and on the protective hood.
- 2) Set START/STOP switch (A) to | .
- 3) Gently press primer bulb (B) often enough that no more bubbles are visible (approx. 7 times).
- 4) Set choke lever (C) fully downwards (FULL CHOKE |←|).

See quick start videos at [www.gardenservicecentre.co.uk](http://www.gardenservicecentre.co.uk) for more information.

# Operating the Grass Trimmer

## Step 2 - Starting the Engine (continued)

- 5) Use your left hand to hold the appliance firmly by the rear handle.
- 6) Pull out the pull cord until you feel resistance. Then pull vigorously 3 to 4 times. When the engine ticks over (the engine has ignited).
- 7) Set the choke lever to the mid-position (HALF CHOKE |↖|).
- 8) Pull the start grip (D) again quickly and strongly until the motor runs.
- 9) After about 30 seconds of warming up and getting up to speed you can operate the machine.

### 2b Start it in warm condition as following steps

- 1) Set the switch to | .
- 2) Set the choke lever to (RUN |↑|).
- 3) Pull the starter grip (D) quickly until engine runs.

## Step 3 - Trimming



**WARNING!**  
- Never operate this unit on the operator's left side.

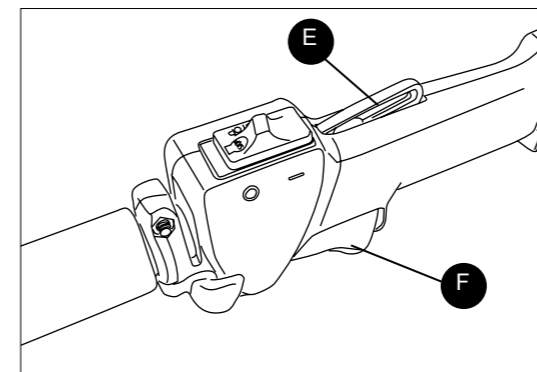

### 2e Running Throttle Position

Hold the trimmer with the right hand on the rear handle and the left hand on the front handle. Press and hold the throttle lockout trigger (E) and squeeze the throttle trigger (F) as required.

Keep a firm grip with both hands while in operation.

The trimmer should be held in a comfortable position with the rear handle about hip height.

Always operate trimmer at full throttle.

# Operating the Grass Trimmer

## Step 4 - Extending spool line while trimming

**! WARNING!** Ensure there is mixed fuel in tank with the correct ratio of fuel to oil. Make sure all guards and handles are properly and securely attached.

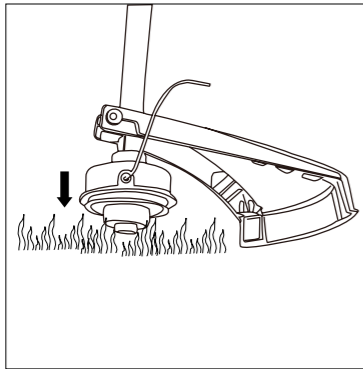

- 1) While the line spool is running at full speed, tap its underside briefly against the ground.
- 2) If the spool lines are still not sufficiently extended, tap the underside against the ground again.
- 3) If the line has already become too short, it will no longer be extended by pressing the underside against the ground. You must pull it out from the line spool by hand.
- 4) Switch off the motor.
- 5) Lay the machine on the ground.
- 6) Push by hand on the underside of the line spool and pull both lines out until they are somewhat longer than the edge of the protective bonnet. The lines are trimmed to the correct length by the line trimming blade located on the grass trimmer guard.

# Stopping

## Stopping

Release the throttle trigger and set the switch to STOP (0).

# How to Replace the Spool/Spool Line

## Step 1 - Removing the spool

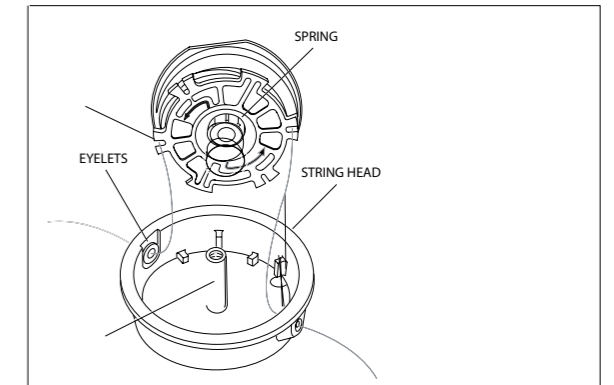
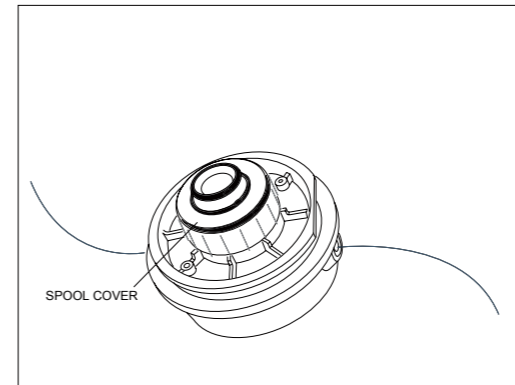

- Twist off (clockwise to loosen) and remove the cover of the spool.
- Remove the spool.

**Do not lose the spring!**

## Step 2 - Replacing the spool line in the spool

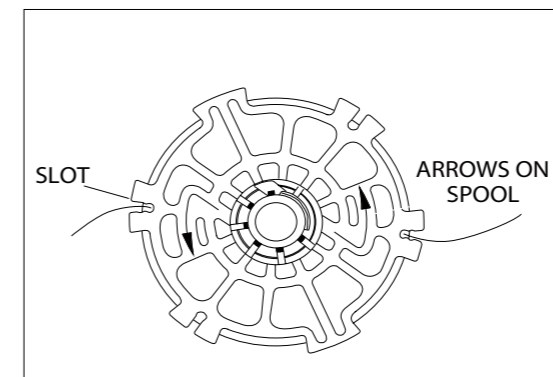
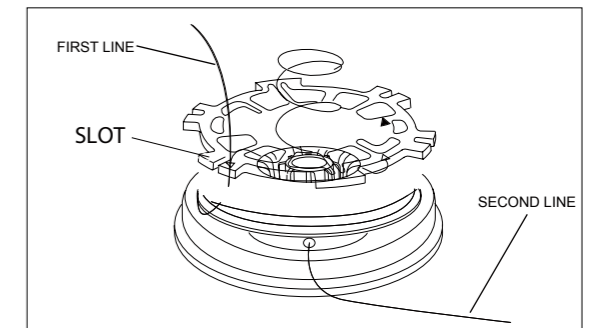
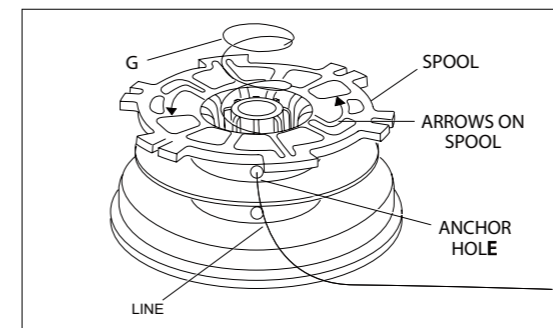

- Completely remove the remains of the spool.
- Make a nick in the middle of the new line, and hook it into the slot in the spool.
- Wind on a spool line on each side of the spool in the direction of the arrow.

# How to Replace the Spool/Spool Line

## Step 3 - Inserting the line spool

- Press both lines into opposite slots (line length about 15 cm).
- Thread both lines into the openings of the spool casing.
- Carefully push the line spool with its spring into the spool casing. When doing so, pull the lines out through the eyelets.
- Continue to hold the line spool tightly. One after the other give a tug on the lines so that they run out of the openings freely.
- Press the line spool in, and turn it clockwise as far as the stop.
- Keep hold of the line spool and twist it slightly back. The line spool must remain firmly fixed in the pushed in position.
- Screw the cover back anti-clockwise onto the line spool and turn it tight by hand. Adjusting the lines to the right length.
- Push on the underside of the line spool by hand and pull out both lines out until they are somewhat longer than the edge of the protective bonnet. The lines are trimmed to the correct length by the line trimming knife.

# Cleaning the Air Filter

## Cleaning the air filter

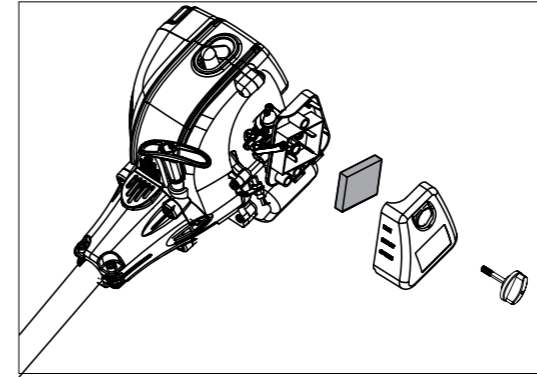

- 1) Loosen the screw from the air filter housing and remove the cap.
- 2) Remove the air filter.
- 3) Wash the air filter in warm water (with a small amount of detergent).
- 4) Rinse the air filter through with clean water.
- 5) Leave the air filter to dry out completely.
- 6) Replace the air filter.
- 7) Replace the cover with the lugs positioned in the notches in the air filter casing.
- 8) Close the lid, and tighten the screw again by hand.

# Replacing the Spark Plug

## Replacing the spark plug

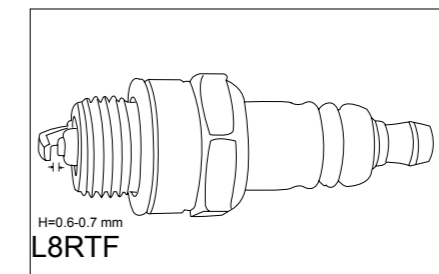
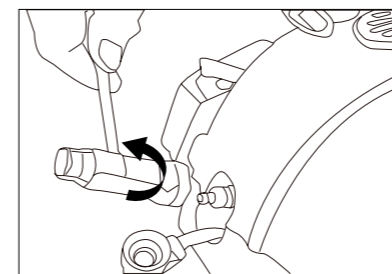

- 1) Disconnect high-tension cable from spark plug.
- 2) Use the spark plug tool to unscrew and remove the spark plug.
- 3) Insert a new spark plug by hand and tighten it carefully with the multifunctional tool.
- 4) Reconnect the high tension cable to the spark plug by pushing the cap over contact on back of the spark plug.

# Storing the Grass Trimmer

## Step 1 - Storing the Grass Trimmer for Short Periods

- Drain all fuel from tank into a container approved for petrol. Run engine until it stops. Clean all foreign material from the trimmer. Store it in a well-ventilated place that is inaccessible to children.
- Keep away from corrosive agents such as garden chemicals and de-icing salts.
- Abide by all ISO and local regulations for the safe storage and handling of petrol. Excess fuel should be used up in other 2-Stroke engine powered equipment.
- Remove any coarse dirt.
- Wipe the machine with a soft damp cloth.

## Step 2 - Storing the Grass Trimmer for Extended Periods

- Clean air filter.
- Replace the spark plug with an exact replacement.

# Maintenance

## Maintenance Schedule

Performing routine maintenance correctly on your grass trimmer will ensure you get years of trouble free use.

Please keep this manual safe for future reference.

It is recommended that the following maintenance schedule is adhered to. This will ensure the grass trimmer operated correctly and is safe to use.

	12 hours of use	24 hours of use	36 hours of use
Air filter	clean	clean	replace
Spark plug	check	clean	replace

## List of consumable parts

901305	air filter
901049	air filter cover
902700	spark plug L8RTF
901313	Fuel filter
901024	string line
902009	string head assy
902221	blade

These parts are available via [www.gardenservicecentre.co.uk](http://www.gardenservicecentre.co.uk)

# Troubleshooting

## General Troubleshooting



### CAUTION!

- Always switch off the engine and remove the high tension cable before starting any inspection or adjustment work.
- If, after making an adjustment or repair to the engine, you let it run for a few minutes, remember that the exhaust and other parts will get hot.

The following table provides solutions to common problems encountered with the grass trimmer.

Fault	Possible Cause	Solution
Engine not starting	<ol style="list-style-type: none"> <li>1. Empty tank</li> <li>2. Flooded engine</li> <li>3. Fouled spark plug (remains of carbon on the electrodes)</li> <li>4. Electrode gap too large</li> <li>5. Fouled carburetor or its jets</li> <li>6. Damaged spark plug connection or damaged spark plug</li> </ol>	<ol style="list-style-type: none"> <li>1. Fill up</li> <li>2. Close the throttle, pull cord several times, if required take out the spark plug and dry it</li> <li>3. Clean the spark plug, check its temperature, replace if needed.</li> <li>4. Adjust at 0.6-0.7 mm</li> <li>5. Clean the carburetor with air</li> <li>6. Replace the spark plug.</li> </ol>
Engine runs too fast when idle	<ol style="list-style-type: none"> <li>1. Cold engine</li> </ol>	<ol style="list-style-type: none"> <li>1. Warm up slowly; alternatively apply the choke slightly.</li> </ol>
Engine does not reach its maximum speed	<ol style="list-style-type: none"> <li>1. Fouled spark plug (remains of carbon on the electrodes) spark gap to large</li> <li>2. Fouled carburettor or its jets</li> <li>3. Fouled air filter</li> <li>4. Exhaust, exhaust channel</li> <li>5. Sealing ring in crankcase not sealing properly</li> <li>6. Wrong fuel mix (too much oil)</li> <li>7. Bad ignition</li> </ol>	<ol style="list-style-type: none"> <li>1. Clean the spark plug, check its temperature, replace if needed. Adjust at 0.6-.07 mm.</li> <li>2. Clean the carburettor with air</li> <li>3. Clean</li> <li>4. Take out the exhaust and clean it, remove remains of carbon</li> <li>5. contact customer helpline, 0845 4505299</li> <li>6. Fill up according to the instructions</li> <li>7. Adjust the ignition coil gap (0.3-0.4 mm)</li> </ol>
Engine would not stop	<ol style="list-style-type: none"> <li>1. The switch failure</li> <li>2. High tension cable has become disconnected.</li> </ol>	<ol style="list-style-type: none"> <li>1. Change the switch.</li> <li>2. Connect high tension cable to spark plug.</li> </ol>

## Technical Data

### Technical Data Table

Property	Value
Engine type	Single-cylinder, 2-stroke
Displacement(cc)	26 cc
Max power /Engine speed	0.6 kW/8000 min <sup>-1</sup>
Max torque/engine speed	0.9 N.m/6000 min <sup>-1</sup>
Max idle speed	3400 min <sup>-1</sup>
Min clutch engaged speed	4300 min <sup>-1</sup>
Tank capacity	410 ml
Cutting diameter	400 mm
Ignition	C.D.I
Diameter of cutting cord	2 mm
Net weight	4,9 kg
Sound pressure level L <sub>PA</sub> (dB)	100 dB K=1.5 dB
Sound power level L <sub>WA</sub> (dB)	112 dB
Vibration (m/s <sup>2</sup> )	12.5 m/s <sup>2</sup> K=1.5 m/s <sup>2</sup>
Spark type	L8RTF

## Disposal

### Disposal Instructions

The grass trimmer and its accessories are made of various recyclable materials. Dispose of the grass trimmer in accordance with your local recycling regulations.

## Getting Help

### Customer Helpline 0845 450 5299

Our dedicated UK based customer helpline is open 7 days a week to assist you with assembly, parts queries and technical support. We are open during office hours but you can always send an email via [support@gardenservicecentre.co.uk](mailto:support@gardenservicecentre.co.uk). Our experts are here to get you back enjoying your garden in no time.

For useful assembly, starting and maintenance videos and ordering spares please visit [www.gardenservicecentre.co.uk](http://www.gardenservicecentre.co.uk).

Calling our service does not affect your statutory rights

## Guarantee

Dear Customer,

In the unlikely event that your device develops a fault, please contact our Customer service department on the telephone number shown below.

1. These guarantee terms cover additional guarantee rights and do not affect your statutory warranty rights.

Claims must be accompanied by Proof of Purchase. This must be in the form of a Sales receipt or Bank statement and must show that the product has been purchased within 2 year prior to the claim, from the retailer that it was originally sold to.

2. Our guarantee covers problems caused by material or manufacturing defects, and will result in the repair of these defects or replacement of the device with a like for like or similar article. Please note that our devices have not been designed for use in commercial, trade or industrial applications. Consequently, the guarantee is invalidated if the equipment is used in commercial, trade or industrial applications or for other equivalent activities.

3. The following are also excluded from our guarantee:

A) Faults due to accidents, customer misuse, or unauthorized repairs

B) Consumable Parts such as Blades/ /Spark plugs or Filters

C) Failure due to lack of routine maintenance

D) Failure as a result of not using the equipment in accordance with the manual and safety instructions

E) The adjustment of cables, drive belts, or recoil starters

4. The guarantee is valid for a period of 2 year starting from the purchase date of the device. Guarantee claims should be submitted before the end of the guarantee period within two weeks of the defect being noticed. No guarantee claims will be accepted after the end of the guarantee period. The original guarantee period remains applicable to the device even if repairs are carried out or parts are replaced. In such cases, the work performed or parts fitted will not result in an extension of the guarantee period, and no new guarantee will become active for the work performed or parts fitted. This also applies when an on-site Service is used.

5. Please keep your sales receipt in a safe place. If the defect is covered by our guarantee your device will either be repaired under the terms of guarantee or we will send you a replacement device. This device may be re-conditioned or Like for like replacement.

# Declaration of Conformity

CE 0359

EC Declaration of Conformity

Year of 1st Issue . 12

Argos Ltd

489-499 Avebury Boulevard  
Saxon Gate West  
Milton Keynes  
Buckinghamshire  
MK9 2NW

We hereby certify that the product stipulated above complies with all the relevant provisions of the following EC new approach directives.

**This declaration of conformity is issued under the sole responsibility of the manufacturer**

Type of Product: Petrol grass trimmer

Model Number: CDB26  
Cat / Article Number: 7305382

Product Description:  
26cc, 2-stroke  
Maximum motor output 0.6kW at 8000min<sup>-1</sup>  
Maximum motor speed 8000min<sup>-1</sup>  
Diameter of trimming area 400mm  
Filament diameter 2mm

Photograph:



Applicable EC Directives		
--------------------------	--	--

- 2006/42/EC (MD)
- 2006/95/EC (LVD)
- 89/686/EEC (PPE)
- 2009/142/EC (Gas)

- 2004/108/EC (EMC)
- 2009/105/EC (Pressure)
- 2009/48/EC (Toys)
- 89/106/EEC (Construction)

- 1999/5/EC (R&TTE)
- 2011/65/EU (RoHS)
- 2000/14/EC Annex V , 2005/88/EC  
Measured sound power level = 103.9 dB  
Guaranteed sound power level = 112 dB(A),  
K= 3 dB(A)  
Cutting width L=40 cm
- Directive 97/68/EC , as last amended by  
Directive 2004/26/EC

Applicable Harmonized Standards:	Verification of conformity	
	Certificate	Notified Body
EN ISO 11806-1:2011	CE	Intertek
ISO22868	Noise	Intertek
EN ISO14982:2009	EMC	Intertek

Issued number: 1

Issued on : 2013-9-11

Signed :

Creator: Max Shi

Name : Lake Wang

Position: QA

Position: Technical Manager

The associated technical file for this product can be found within e-Document system by contacting persons named above