

POWERBASE

46cm 40V Self Propelled Cordless
Lawn Mower 577154

Instruction Manual

IMPORTANT!
Please read these
instructions fully before
starting assembly.



These instructions contain important information that will help you get the best from your product, ensuring it is assembled correctly and safely. If you need help or have damaged or missing parts, call the Customer Helpline on 01904 727 509.

Contents

General safety warnings	3
Intended use	11
Warning symbols	12
In the box	15
Assembling the lawn mower	16
Operation	21
Maintenance and storage	29
Troubleshooting	32
Technical data	33
Havs	34
Disposal	34
Getting help	34
Warranty	35

General Safety Warnings

Safety warnings



WARNING! Read all safety warnings and instructions.

Failure to follow the warnings and instructions may result in electric shock, fire and/or serious injury.



WARNING! Read all safety warnings and instructions designated by the  symbol.

Save all warnings and instructions for future reference.

- This machine cannot be used by children and persons with reduced physical, sensory or mental capabilities or lack of experience and knowledge if they have been given supervision or instruction concerning the use of the machine in a safe way and understand the hazards involved.
- Children should be supervised to ensure that they do not play with the product.

IMPORTANT! Before assembling the lawn mower, check all the parts indicated in the manual are in the box. Inspect all the parts for signs of damage. Do not assemble the lawn mower if you observe any damaged components.

General safety

Training

1. Read the instructions carefully and make sure you fully understand them. Make sure you are familiar with the controls and the correct use of the product.
2. Never allow small children or people unfamiliar with these instructions to use the product. Local regulations can restrict the age of the operator.
3. Never operate the product while people, especially children or pets, are nearby.
4. Keep in mind that the operator or user is responsible for any accidents or hazards occurring to other people or their property.

Preparation

1. While operating the product always wear substantial footwear and long trousers. Do not operate this product when barefoot or wearing open-toed sandals. Avoid wearing clothing that is loose fitting or has hanging cords or ties.
2. Thoroughly inspect the area where the product is to be used and remove all objects which could be thrown by the product.
3. Before use, always visually inspect to see that the blade, blade bolt and the blade assembly are not worn or damaged. Replace worn or damaged components

in sets to preserve balance. Replace any damaged or unreadable labels.

4. Ensure the switch is in the off position before inserting the battery pack. Inserting the battery pack into a machine that is switched on can result in injury.

Product safety warnings

General Operation

1. Use the tool only with specifically designated battery packs. Use of any other battery packs will increase the risk of injury and fire.
2. Only operate the product in daylight or in good artificial light.
3. Do not expose the machine and charger to rain or wet conditions. If a machine or charger is exposed to moisture it will increase the risk of electric shock.
4. Avoid operating the product on wet grass.
5. Always be sure of your footing on slopes.
6. Walk, never run.
7. Mow across the face of slopes, never up and down.
8. Exercise extreme caution when changing direction on slopes.
9. Do not mow excessively steep slopes.
10. Use extreme caution when reversing or pulling the product towards you.

11. Stop the blades if the product has to be tilted for transportation, when crossing surfaces other than grass, and when transporting the product to and from the area to be mowed.
12. Never operate the product with defective guards or shields or without safety devices in place, such as deflectors or the grass collector.
13. When switching on the motor, keep feet well away from the blades.
14. Do not tilt the product when switching on the motor, except if the product has to be tilted for starting. In this case, do not tilt it more than absolutely necessary and lift only the part furthest away from the operator.
15. Do not start the product when standing in front of the discharge opening.
16. Keep clear of the discharge opening at all times.
17. Do not put hands or feet near or under rotating parts.
18. Do not transport the product while the cutting blade is running.
19. Stop the product and remove the key/ battery pack from the machine and make sure that all moving parts have come to a complete stop:
 - Whenever you leave the product unattended.
 - Before clearing blockages or unclogging chute.

- Before checking, cleaning or working on the product.
- After striking a foreign object. Make sure to inspect the product for damage and make repairs before restarting and operating the product.

20. If the product starts to vibrate abnormally:

- Inspect for any damages.
- Replace or repair any damaged parts.
- Check for and tighten any loose parts.

Charger

1. Recharge only with the charger specified by the manufacturer. Do not use the original charger on other li-ion batteries or on any other type of battery, as this can increase the risk of fire or explosion.
2. Check the battery charger, cable and plug before each use. Do not use the battery charger if damaged. Do not open the battery charger yourself; the charger must be repaired by qualified personnel using original spare parts.
3. The charger is designed to use a standard household 220-240 V~ 50Hz power source. Ensure that the plug matches the outlet.
4. Never modify the plug in any way, this will reduce the risk of electric shock.

5. Do not abuse the cord of the charger. Never use the cord for carrying, pulling or unplugging the charger. Keep the cord away from heat, oil, sharp edges and moving parts. Damaged or entangled cords increase the risk of electric shock.
6. Make sure the charger cord is situated so that it will not be stepped on, tripped over or get damaged.
7. Keep the battery charger clean. Contamination can increase the risk of electric shock.
8. Protect the battery charger from rain and moisture. If water accesses the battery charger there is an increased risk of electric shock.
9. Battery will heat up whilst charging. To reduce the risk of fire, do not operate the battery charger on flammable surfaces such as paper or textiles.
10. The temperature range over which the battery pack can be charged is typically between 5°C-45°C. Attempts to charge outside of the prescribed temperature range may automatically be blocked by the protection circuitry of the battery pack. Longest life and best performance can be obtained if the battery pack is charged at room temperature.
11. Disconnect charger from the power supply when not in use. This will reduce the risk of electric shock or damage to the charger.

Battery pack

1. Fully charge the battery pack before first use.
2. Recharge the battery pack immediately when the power output starts to slow. **DO NOT CONTINUE TO USE THE PRODUCT WHEN BATTERY LEVEL IS LOW.**
3. To prevent serious damage to the battery, charge in temperatures above 5°C or below 45°C. Longest life and best performance can be achieved when the battery is charged at room temperature.
4. If the battery temperature is above 45°C it must be allowed to cool before putting it into the charging station.
5. To reduce the risk of explosion, ensure the battery pack is not left in the sun for extended periods of time and that it is kept away from fire.
6. Do not carry individual battery packs in your pockets or bag as they could short-circuit against other metal items.
7. Should a li-ion battery catch fire, be sure to use the correct fire extinguisher to combat the fire. **DO NOT THROW WATER ON A BURNING LI-ION BATTERY.**
8. If the battery pack becomes too hot during charging, disconnect and switch off immediately. Contact the service centre directly.
9. Do not attempt to open the battery yourself.

10. When the battery pack is not in use, keep it away from other metal objects, such as paperclips, coins, keys, nails, screws or other small metal objects that can make a connection from one terminal to another.

Maintenance and storage

1. Keep all nuts, bolts and screws tight to be sure the product is in a safe working condition.
2. Check the grass collector frequently for wear or deterioration.
3. Be careful when adjusting the product to prevent trapping fingers between moving blades or other fixed parts of the product.
4. Always allow the product to cool down before storing.
5. When servicing the blades, be aware that even though the power source is switched off, the blades can still move.
6. Replace worn or damaged parts for safety. Use only genuine replacement parts and accessories.
7. DO NOT attempt to open the charger and battery pack. There are no customer serviceable parts inside. Return to any authorised service centre.
8. Store the appliance with the battery pack fully charged at room temperature (around 20°C).

9. Every deep discharge cycle decreases the capacity of the battery pack. To prolong battery life, it is recommended that you charge the battery every six months within extended periods of time when the product is not in use.

Servicing

1. Have your machine repaired by an authorised service agent. This product is manufactured in accordance with the relevant safety regulations. To avoid danger, equipment must only be repaired by qualified technicians.
2. Only use parts and accessories made for this machine by the manufacturer. Failure to do so can result in personal injury.

Intended Use

This lawn mower is designed for domestic lawn mowing only. Use in any other way is considered contrary to the intended use. Compliance with the operation, service and repair, as specified in this manual, also constitutes essential elements of the intended use. Failure to comply can void the warranty.

Warning Symbols

The purpose of safety symbols is to attract your attention to any possible dangers. The safety symbols and their explanations deserve your careful attention and full understanding. The symbol warnings do not, by themselves, eliminate any danger. The instructions and warnings they give are no substitute for proper accident prevention measures.



WARNING: Be sure to read and understand all safety instructions within this operator's manual, including all safety alert symbols such as '**DANGER**', '**WARNING**', and '**CAUTION**' before using this tool. Failure to follow all instructions listed below may result in electric shock, fire and/or serious personal injury.

SAFETY ALERT SYMBOLS: Indicate **DANGER**, **WARNING**, or **CAUTION**. May be used in conjunction with other symbols or pictographs.

Symbol meanings

This page depicts and describes safety symbols that may appear on this product. Read, fully understand and follow all instructions on the machine before attempting to assemble and operate.



To reduce the risk of injury, the user must read the instruction manual carefully.



Avoid using the machine in the rain.

Wait until all machine components have completely stopped before touching them.



Keep bystanders away. Objects thrown by the product could hit the user or other bystanders. Always ensure that other people and pets remain at a safe distance from the product when it is in operation.



Beware of sharp blades. Blades continue to rotate after the motor is switched off. Remove disabling device before performing any maintenance tasks.



Guaranteed sound power level value is 96 dB.



Wear ear protection, eye protection and protective gloves (PPE) when using the product.



WEEE symbol. Waste electrical products should not be disposed of with household waste. Please recycle where facilities exist. Check with your local authority or local store for recycling guidelines.



The product complies with the applicable European directives and an evaluation method of conformity for these directives was done.

Warning symbols on the battery pack



To reduce the risk of injury, the user must read the instruction manual carefully.



Do not throw into water.



Do not throw on fire.



Do not subject the battery to strong sunlight over long periods of time. Do not leave on a heater (max. 45°C).



Batteries contain Li-ion. Do not dispose of waste batteries in domestic waste. Contact local authority to find out how to dispose of batteries.

Warning symbols on the charger



To reduce the risk of injury, the user must read the instruction manual carefully.



The charger is for indoor use only.



Class II equipment.



Protective 5A limited.



WEEE symbol. Waste electrical products should not be disposed of with household waste. Please recycle where facilities exist. Check with your local authority or local store for recycling advice.



The product complies with the applicable European directives and an evaluation method of conformity for these directives was done.

In the Box

Parts

- A. Lawn mower with upper handle
- B. Grass collection bag
- C. Charger
- D. Mulching plug
- E. Side discharge chute
- F. Manual
- G. Battery pack x 2
- H. Cable clip x 2
- I. Quick-release clamp x 2

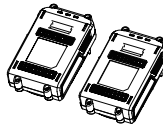
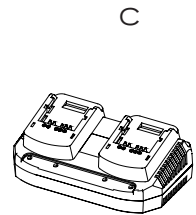
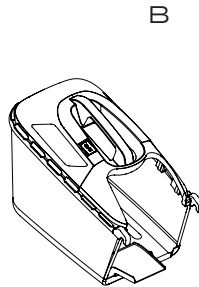
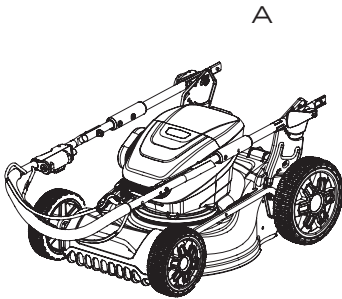

Assembling the Lawn Mower

Parts

1. Self-propelled switch lever
2. Safety button
3. Grass bag
4. Cutting height adjustment lever
5. Side discharge chute
6. Front carry handle
7. Power head
8. Quick-release clamp
9. Start/stop lever

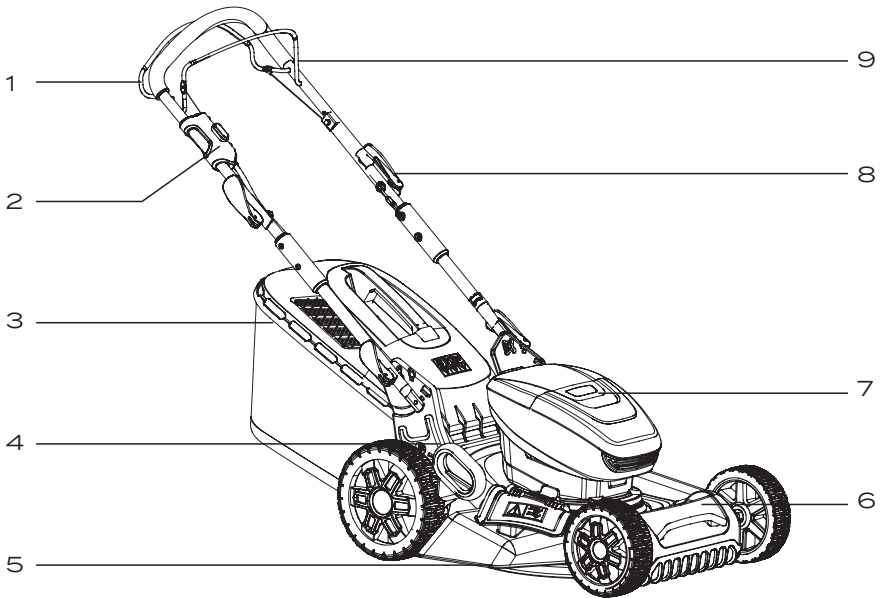



WARNING: Ensure the battery pack is disconnected from the mower before making the assembly.

Unfold the handle

1. Rotate the handle quick-release levers to release the operation handle (both sides).

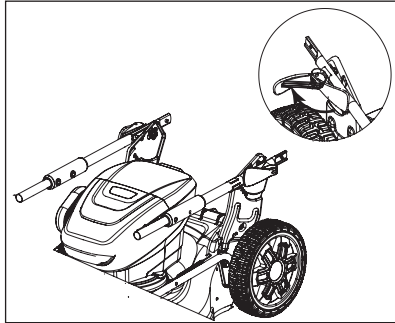

2. Rotate the handle and then position the lower handle lock pin into the mower bracket - one of the three angle positions (both sides).

Note: keep the handle of both sides at the same angle position.

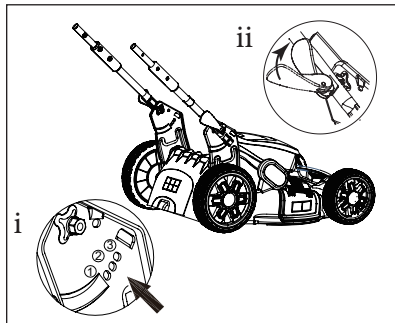

3. Lock the handle in place by closing the handle quick-release levers - make sure that the handle is securely locked in position (both sides).

Attach the top handle to the lawn mower

Mount the top handle to the lower handle by using two quick-release clamps (screw with curved head).

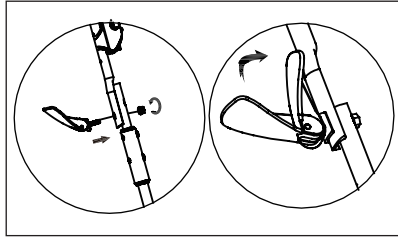

Fitting the cable clip

Ensure that the cable clips supplied are used to fix the cable to the lower handle.

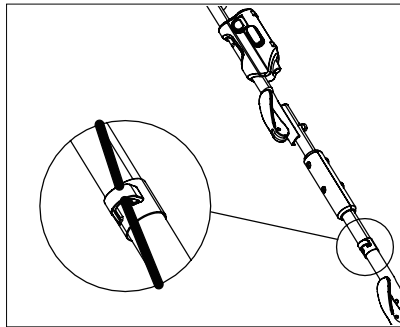

Attach the grass bag

Attach the grass bag to the frame by fixing the plastic hooks onto the side.

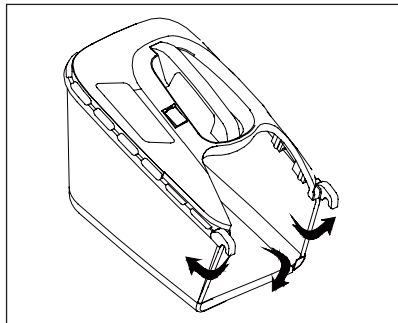

Lift the safety flap with one hand and hook in the grass bag. Release the ejector flap to secure the grass bag in position.

NOTE: Make sure the mulching plug is not in the rear chute of deck.

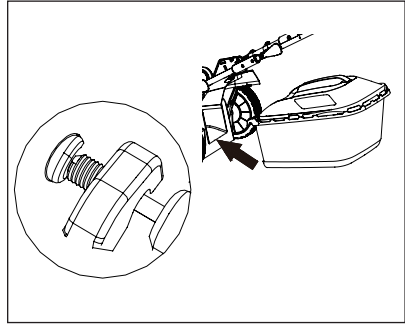
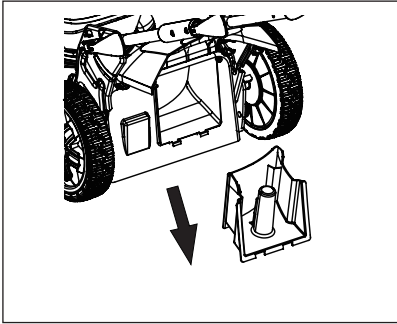

Installing the mulching plug

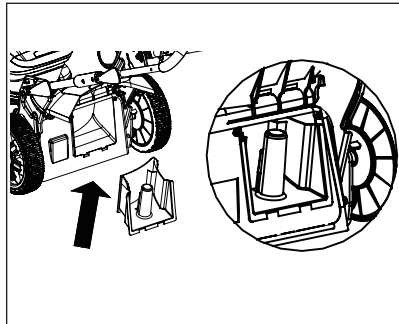

1. Lift the rear flap with one hand and push the mulching plug into the rear discharge chute until it is locked in place. Make sure that the mulching plug is locked in position.
2. Release the rear safety flap; it will close back to cover the mulching plug.

Installing the side discharge chute

1. Lift the side discharge cover with one hand and hook in the side discharge chute with the other hand.

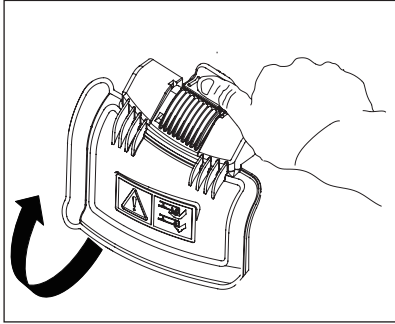

2. Release the side discharge cover to secure the chute in position.

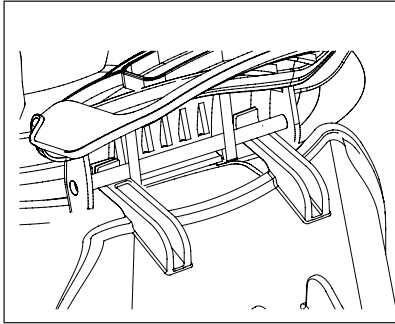

Set required function



WARNING! Before changing any accessory, switch off the machine and make sure that the blade has stopped completely.

NOTE: This lawn mower has three functions. These functions can be converted by changing accessory settings as described above. Please see the following chart for detail.

	Mulching plug	Grass collection bag	Side discharge chute
Collection	x	√	x
Mulching	√	x	x
Side Discharge	√	x	√

‘√’: installed ‘x’: uninstalled

Operation

Charging the battery pack



NOTE: The battery pack comes partly charged. Charge the battery pack prior to first use, ideally at least 60 minutes.

- Always pull out the plug of the charger from the mains before removing or connecting the battery pack to the charger.
- Never charge the battery pack when the ambient temperature is below 0°C or above 45°C.
- Never recharge a battery pack again immediately after rapid charging. This could overcharge the battery pack, thus reducing the lifespan of the battery pack and charger.
- Rest the charger for at least 15 minutes between continuously charging sessions.
- If no battery pack is inserted into the charger and the charger is connected to mains, the charging status LED shows red.



NOTE: Always fully charge the two batteries at the same time.

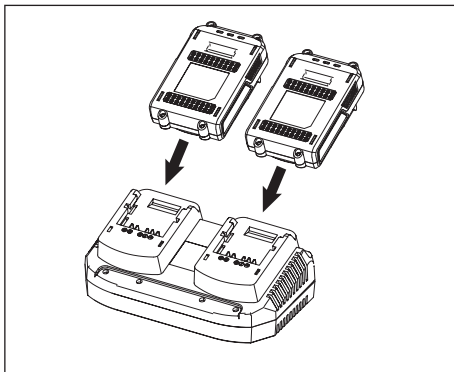

Checking battery capacity

Press the battery capacity level button to check the charging level of the battery pack. The status/remaining charge will be shown on the battery charging level indication light.

3 Green LEDs continuously lit	Battery pack fully charged
2 Green LEDs continuously lit	Battery pack 65% charged
1 Green LEDs continuously lit	Battery pack 35% charged
No LED lit	Battery is dead and needs to be charged

Charge the battery pack before operating when it is at medium or low battery charging level.

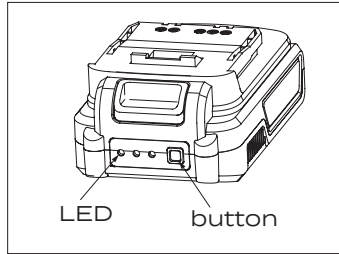

- i. Connect the battery pack to the battery charger.
- ii. Insert the mains plug into the socket. The green charging status LED light will flash. Once the battery pack is completely charged, the green charging status LED is lit continuously, indicating that the charging process is complete.
- iii. Disconnect the charger from the mains and remove the battery pack from the charger.
- iv. Attach the battery pack back to the product.

Charging status LEDs

Red LED turns on	Charger ready
Green LED flash	Battery pack charging
Green LED continuously lit	Battery pack fully charged
Red and green LEDs flashing	Battery pack defect
Red and green LEDs continuously lit	Battery pack too cold or warm

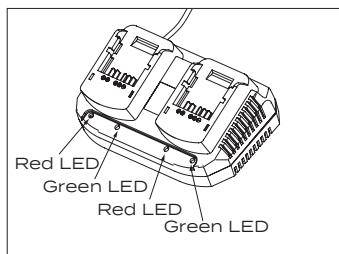

To obtain the best life from the battery

1. Never allow the battery to completely discharge before recharging. The battery pack should be placed on the charger whenever the battery pack is noticeably running down or the machine no longer performs a task it previously performed.
2. Avoid conducting short charges. Make sure that the battery is fully charged each time by allowing the charger to complete its full charging cycle.
3. Avoid allowing loose items like screws or nails, etc., to be stored with battery packs, as these or similar items can short battery packs and cause a fire or explosion.
4. Always unplug the charger when not in use and store in a dry and secure place.
5. Avoid charging or storing your battery in temperatures below 5°C and above 45°C.
6. After use, allow the battery to pack to cool down for approximately 30 minutes before attempting to recharge.

Removing and inserting the battery pack

Insert the battery pack

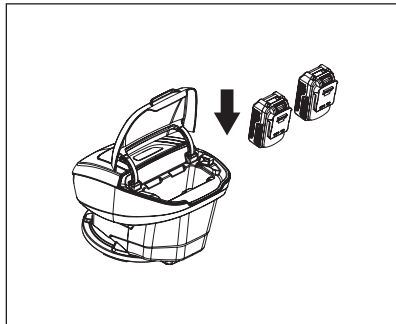

Align the battery pack with its compartment on the machine. Push the battery pack into the tank until you hear a click. This means the battery pack has been locked in position, then close the battery pack tank cover.

Removing the battery pack from the machine

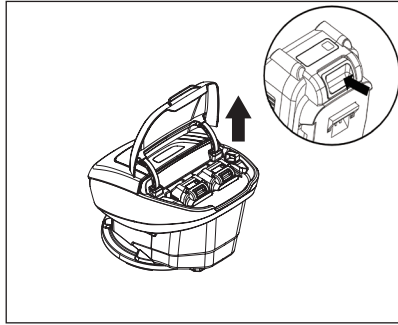

Open the battery pack tank cover. Push the battery pack release button just on the battery pack, then pinch the button (not loose) and pull it out.

Safety Key

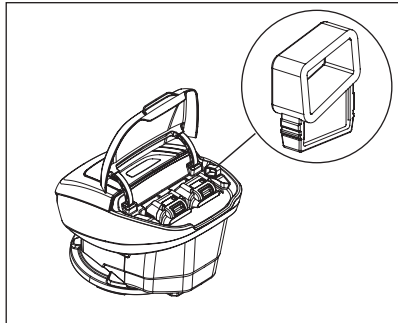

This lawn mower is fitted with a safety key; this prevents the accidental startup of your cordless lawn mower.

The safety key has been designed to totally disable the lawn mower when it is removed.

Setting the cutting height

If you wish to change the cutting height, push the adjusting lever first to make it out of the tooth and then push the lever to the desired position.

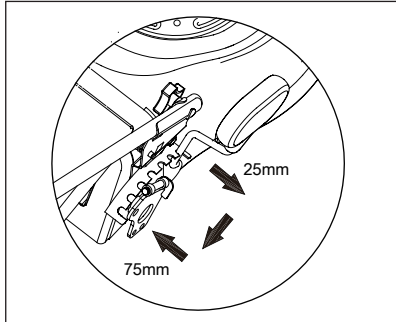

WARNING: Never operate the adjusting handle roughly.

Switching on and off

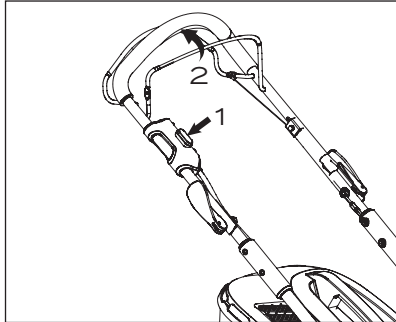

Switch on:

1. Press and hold the safety button on the side of the switch box with one hand.
2. Pull the switch bar towards the handle and hold it with the other hand.
3. Release the safety button.

Switch off:

Release the switch bar.

Using the drive function

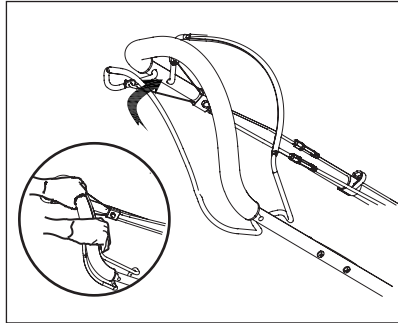

This unit is self propelled.

1. Start the mower as previously mentioned.
2. Use one hand to hold the switch bar firmly pressed against the main handle.
3. Use your free hand to press the drive control bar towards the main handle, and grip the main handle with both hands. The drive system will engage immediately and the mower will move forward automatically.
4. Release the drive control bar to disengage the drive system; the mower will stop moving. Releasing the switch bar will stop the mower. This will also stop the drive system.



WARNING: When the mower has been switched off, the blade will continue to run for several seconds. Do not touch the underside of the mower until the cutter has come to a complete standstill!

Operating the lawn mower



WARNING: Ensure the battery pack is disconnected from the mower before making any adjustment, cleaning and maintenance.

Operation on a slope:

Slopes increase the risk of slip-and-fall accidents, which can result in severe injury. Always be sure of your footing on slopes. Operation on slopes requires extra caution. If you feel uneasy on a slope, do not mow it.

Do:

- Mow across the face of slopes, never mow up and down. Exercise extreme caution when changing direction on slopes.
- Watch for holes, ruts, rocks, hidden objects or bumps which could cause you to slip or trip. Tall grass can hide obstacles.

Do not:

- Do not mow near drop-offs, ditches or embankments; you could lose your footing or balance.
- For safety reasons, do not use the mower on gradients exceeding 15°.
- Do not mow on wet grass. Unstable footing could cause you to slip.

Mower overload protection

To prevent overload conditions, do not try to cut too much grass at one time. Slow down your cutting pace or raise the cut height. Your mower has built-in overload circuit protection. When the mower is overloaded, the mower will stop. Switch the mower off and check to see if grass has collected beneath the deck and clear it if necessary, then restart the mower.

Battery high temperature protection

The battery pack will generate heat during operation. The heat dissipates slower in hot weather. If the battery temperature exceeds more than 70°C during operation, the protection circuit will immediately turn off the mower to protect the battery pack from damage. Release the switch bar, wait until the battery pack cools down and then restart the mower.

Function of full indicator

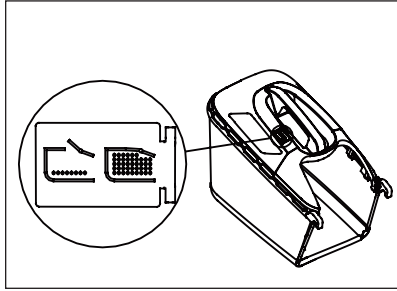

If the grass bag is empty or it is not filled with grass, the grass full indicator will be open.

If the grass bag is filled with grass, the grass full indicator will be closed.

Emptying the grass bag

As soon as the grass bag indicator closes while you are mowing, this means that it is time to empty the grass bag.

NOTE: Before removing the grass bag, switch off the mower, disconnect the battery pack and wait until the blade has come to a complete stop.

To take off the grass bag, use one hand to lift up the safety flap and the other to grab on to the carry handle of the grass bag. The safety flap automatically falls down after removing the grass bag and closes off the rear chute opening.

Empty out the grass bag then refit to mower.

NOTE: If any grass residue is caught in the discharge chute, clean it using a brush. Do not remove grass debris in the mower casing or on the blade by hand or with your feet. Instead, use suitable tools, such as a brush or broom. To ensure that the cut grass can be collected into the grass bag, the discharge opening and inside the mower casing must be cleared of any blockages.

Maintenance and Storage



WARNING: Before performing any maintenance or cleaning work, always ensure that the battery pack/safety key has been removed. Wait until the blade has stopped completely and the machine has cooled down.

Cleaning

Cleaning the product

- Use a soft brush to remove accumulated dust and debris. Wear safety glasses to protect your eyes whilst cleaning.
- Wipe down the product enclosure with a slightly damp cloth. Do not spray the unit with water. Water may destroy the switch unit and the electric motor.

Maintenance

NOTE: Always wear gardening gloves when handling or working near sharp blades.

1. Keep all nuts, bolts and screws tight to ensure that the machine is in a safe working condition.
2. Check the grass bag frequently for wear or deterioration.
3. Examine the machine and replace worn or damaged parts for safety.

Removing/installing the blade

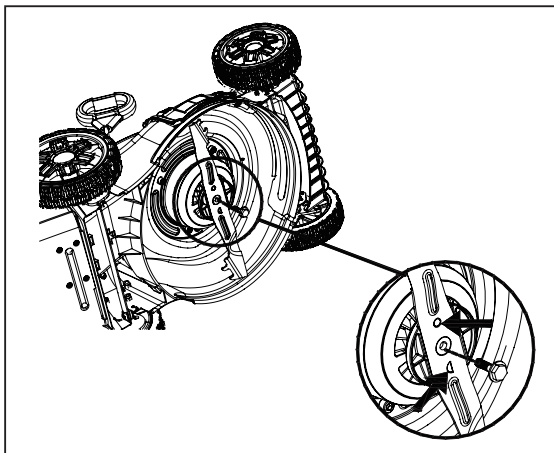

1. Use the correct size wrench to uninstall the blade bolt nut.
2. Wearing heavy gloves, hold the blade still and turn the wrench anti-clockwise to remove the bolt.
3. Fit the replacement blade correctly with the markings facing up and align the pegs, refit the bolt and retighten securely to torque 20N.m.



WARNING: Replace or re-sharpen the mowing blade at the end of the mowing season. Always have the mowing blade re-sharpened or replaced by a recommended service centre.

Unbalanced blades will cause the lawn mower to vibrate violently, which can increase the risk of accidents occurring.

Battery maintenance:

Use the following procedures to achieve the best battery life:

1. Protect the battery against moisture and water.
2. Store the battery only within temperature range of 5°C to 45°C. Do not leave the battery in direct sunlight for extended periods of time.
3. Clean the battery regularly with a soft, clean and dry brush.
4. If you do not use the product for a long time, remember to charge and discharge the battery pack once every 6 months.

Storage and transport

Storage

After cleaning the unit thoroughly, store the lawn mower in a dry room and allow the motor to cool down.

To reduce storage space, the lawn mower can be folded.

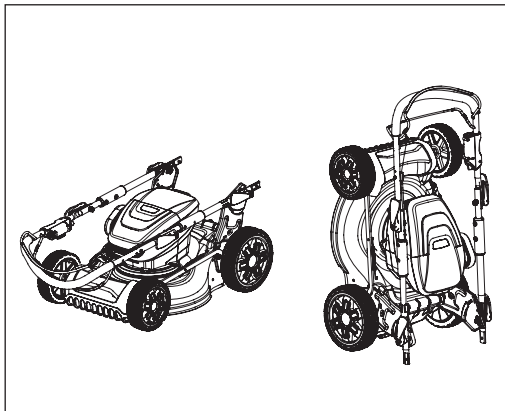

1. Loosen the quick-release lock system on the handles.
2. Fold the handles.
3. Stand up the mower and store.

NOTE: Remove the safety key and battery packs. Ensure cables are not trapped when folding/unfolding the handle. If stored vertically, make sure the mower is positioned in a corner so that the blade is facing inwards against a wall, and the machine is secure to prevent it falling over.

Transport

Use the original packaging to ship whenever possible.

Consumable parts

Part No.	Part Name
1001036000	Grass bag
1251889000	Blade
0240148000	Charge
0240216000	Battery

Troubleshooting





WARNING! Before performing any repair work, always ensure that the battery pack has been removed.

WARNING! Always wear heavy-duty gloves when adjusting or cleaning, especially when handling sharp objects.

Fault	Possible cause	Solution
Mower fails to start	Safety key is not inserted	Insert safety key
	Battery is not correctly inserted	Remove battery and reinsert
	Mower standing in high grass	Start motor on shorter grass or already mowed area, change cutting height if necessary
	The mower housing is clogged	Clean housing so blade can move freely
	Battery has no power	Check and recharge battery
Mower stops working/loses power	Cutting height is incorrect	Adjust cutting height
	Cutting blade is worn or damaged	Replace with new blade from dealer service centre
	Battery performance decreasing	Check battery performance and charge if necessary
Grass bag is not filled sufficiently	Cutting height is too Low	Adjust and increase cutting height
	The lawn/grass is wet	Allow lawn to dry
	Underside of mower deck is clogged	Clean underside of mower deck
	Cutting blade is worn or damaged	Replace by contacting customer service centre
Mower vibrating at higher speed	Cutting blade is unbalanced	Balance blade by grinding each cutting edge until equal
	Blade is loose/incorrectly fitted	Tighten blade bolt
Mower cuts unevenly	The blade is damaged	Sharpen blade or replace
	Blade is assembled incorrectly	Re-assemble blade correctly

Technical Data

Property	Value
Model no.	YOJZ-SPO3-464OZA
Nominal voltage of product with battery	40V(2X20V)  / 5Ah
No-load cutting speed	3200min ⁻¹
Cutting width	46cm
Cutting height	25-75mm, 7 positions
Capacity of grass bag	55l
Weight	27.3kg
Measured sound pressure level(L _{PA})	77dB(A), K=3dB(A)
Measured sound power level(L _{WA})	89.23dB(A), K=1.14dB(A)
Guaranteed sound power level	96dB(A)
Vibrations	1.89m/s ² K=1.5m/s ²
Battery pack model	BOP-SPO6-20ZH
Battery capacity	20V  5Ah
Battery charging time	100min
Battery charger model	BOP-SPO7-204OZB
Input	220-240V~, 50/60Hz 120W
Output	21V  4A
Protection class	□ / II

The sound values have been determined according to noise test code given in EN 60335-2-77, using the basic standards EN ISO 11201 and EN ISO 3744.

The sound intensity level for the operator may exceed 80 dB(A) and ear protection measures are necessary.

The declared vibration value has been measured in accordance with a standard test method (according to EN 60335-2-77) and may be used for comparing one product with another. The declared vibration value may also be used in a preliminary assessment of exposure.



WARNING: Depending on the actual use of the product the vibration values can differ from the declared total! Adopt proper measures to protect yourself against vibration exposure! Take into consideration the whole work process, including times the product is running under no load or is switched off.

HAVS



WARNING! This equipment may cause Hand-Arm Vibration Syndrome (HAVS) if its use is not adequately monitored and managed.

Preventative measures include, among others, regular maintenance and care of the product and cutting attachments, keeping hands warm and periodical breaks, as well as proper planning of work processes.

Disposal

The lawn mower and its accessories are made of various recyclable materials. Dispose of the lawn mower in accordance with your local recycling regulations.

Getting Help

Our dedicated UK-based customer helpline is open 7 days a week to assist you with assembly, parts queries and technical support. We are open during office hours but you can always send an email via **support@coreservice.co.uk**. Our experts are here to get you back enjoying your garden in no time.

For useful assembly, starting and maintenance videos, and for ordering spares, please visit **www.coreservice.co.uk**.

Calling our helpline does not affect your statutory rights.

Warranty

This product is covered by a 2 year warranty.

The warranty covers any manufacturing defect in materials, workmanship and finish.

Any claim under this warranty must be made by going to your nearest Homebase store, taking your proof of purchase with you, and claims must be made within 2 years of the date of purchase.

We will offer you a free repair of the item where this is possible, or a replacement or a refund. Your statutory rights remain unaffected, in particular any rights you may have under the Consumer Rights Act 2015.

This warranty is given by HHGL Limited, MK9 1BA; HHGL (ROI) Limited, DO2 X576.

Please note: This warranty does not apply to products misused or neglected and only covers domestic use. It does not apply to commercial use of the product. In addition, the warranty will be void for the following reasons: Any damage resulting from product misuse or product neglect.