

POWERBASE

36cm 1050W Electric
Tiller

577184

Instruction Manual

IMPORTANT!
Please read these
instructions fully before
starting assembly.



These instructions contain important information that will help you get the best from your product, ensuring it is assembled correctly and safely. If you need help or have damaged or missing parts, call the Customer Helpline on 01904 727 509.

Contents

General safety warnings	3
Intended use	9
Warning symbols	11
In the box	13
Assembly	14
Preparation	16
Operation	19
Maintenance and repair	20
Troubleshooting	23
Technical data	24
Disposal	25
Getting help	25
Warranty	26

General Safety Warnings

Safety warnings



WARNING!

Read all safety warnings and all instructions. Failure to follow the warnings and instructions may result in electric shock, fire and/or serious injury. Carefully read the instructions for the safe operation of the machine. Save all warnings and instructions for future reference.

- This machine **MUST NOT** be used by children and persons with reduced physical, sensory or mental capabilities, or lack of experience and knowledge, unless they have been given supervision or instruction concerning the use of the machine by a person responsible for their safety.
- Local regulations can restrict the age of the operator.
- Children should be supervised to ensure that they do not play with the machine.

Safe operating practices for electric tiller



IMPORTANT!

READ CAREFULLY BEFORE USE

KEEP FOR FUTURE REFERENCE

Training

- Read the instructions carefully. Be familiar with the controls and the proper use of the equipment.
- Never allow children or people unfamiliar with these instructions to use this machine. Local regulations can restrict the age of the operator.
- Never operate the machine while people, especially children or pets, are nearby.
- Keep in mind that the operator or user is responsible for accidents or hazards occurring to other people or their property.

Preparation

- While operating the machine, always wear suitable footwear and long trousers. Do not operate the machine when barefoot or wearing open-toed sandals. Avoid wearing clothing that is loose fitting or that has hanging cords or ties.

- Thoroughly inspect the area where the machine is to be used, and remove all objects which can be thrown by the machine.
- Before using, always visually inspect to see that the blade, blade bolt and the blade assembly are not worn or damaged. Replace worn or damaged components in sets to preserve balance. Replace damaged or unreadable labels.
- Before use check the supply and extension cord for signs of damage or aging. If the cord becomes damaged during use, disconnect the cord from the power supply immediately. **DO NOT TOUCH THE CORD BEFORE DISCONNECTING THE SUPPLY.** Do not use the machine if the cord is damaged or worn.

Operation

- Operate the machine only in daylight or in good artificial light.
- Always be sure of your footing on slopes.
- Walk, never run.
- For wheeled rotary machines, work across slopes, never up and down.
- Exercise extreme caution when changing direction on slopes.
- Do not work on excessively steep slopes.

- Use extreme caution when reversing or pulling the machine towards you.
- Do not change the motor governor settings or over speed the motor.
- Never operate the machine with defective guards or shields, or without safety devices.
- Carefully switch the motor on according to instructions and with feet well away from the cutting mean(s).
- Do not start the machine when standing in front of the discharge opening.
- Do not put hands or feet near or under rotating parts. Keep clear of the discharge opening at all times.
- Do not transport the machine while the cutting blade is running.
- You must stop the machine immediately and remove the plug from the socket (or other disabling device), and make sure that all moving parts have come to a complete stop:
 - whenever you leave the machine;
 - before clearing blockages or unclogging the chute;
 - before checking, cleaning or working on the machine;
 - after striking a foreign object. Inspect the machine for damage and make repairs before restarting and operating the machine.

- If the machine starts to vibrate abnormally, stop immediately and manually:
 - inspect for damage;
 - replace or repair any damaged parts;
 - check for and tighten any loose parts.

Maintenance and storage

- Keep all nuts, bolts and screws tight to be sure the machine is in safe working condition.
- On machines with multi blades, take care as manually rotating one blade can cause other blades to rotate.
- Be careful during adjustment of the machine to prevent entrapment of the fingers between moving blades and fixed parts of the machine.
- Always allow the machine to cool down before storing.
- When servicing the blades, be aware that, even though the power source is switched off, the blades can still be moved manually.
- Replace worn or damaged parts for safety. Use only genuine replacement parts and accessories.

Service

- Have your machine repaired by an authorised service agent. This machine is manufactured in accordance with the relevant safety regulations. To avoid danger, equipment must only be repaired by qualified technicians.
- Only use parts and accessories made for this machine by the manufacturer. Failure to do so can result in personal injury.

Recommendation

- The machine should be supplied via a residual current device (RCD) with a tripping current of not more than 30mA.
- If the supply cord is damaged, it must be replaced by the manufacturer, its service agent or similarly qualified persons, in order to avoid a hazard.
- Do not expose the machine to rain or wet conditions. Water entering the machine will increase the risk of electric shock.
- Supply cords shall not be lighter than
 - if rubber insulated, ordinary tough rubber sheathed exible cord (code designation HO5 RN-F).
 - if polyvinyl chloride insulated, ordinary polyvinyl chloride sheathed flexible cord (code designation HO5 VV-F).

Intended Use

- This product is designed for small gardens and flower beds; this device effectively loosens and turns over new soil. It may also be used to mix coarse soil with fertiliser, peat, and compost. This product may not be used to till extremely dry or wet soil. The use of this product in rain or wet conditions is prohibited.
- For safety reasons, it is essential to read the entire instruction manual before first operation and observe all the instructions herein.
- This product is intended for private domestic use only; not for any commercial trade use. It must not be used for any purposes other than those described herein.

Emergency



WARNING!

Familiarise yourself with the use of this machine by means of this instruction manual. Memorise the safety directions and follow them to the letter. This will help to prevent risks and hazards.

- Always be alert when using the machine so that you can recognise and handle risks early. Fast intervention can prevent serious injury and damage to property.
- If there is any malfunction, switch off and disconnect from the power supply. Have the machine checked by a qualified specialist and repaired if necessary before you put it into operation again.

Residual risks



WARNING!

Even if you are operating the machine in accordance with all safety requirements, potential risks of injury and damage remain. The following dangers can arise in connection with the structure and design of this machine:

- Health defects resulting from vibration emission, e.g. if the machine is being used over long periods of time, or not adequately managed and properly maintained.
- Injuries and damage to property due to broken tools or sudden impact of hidden objects during use. Danger of injury and property damage caused by flying objects.

- Do not abuse the cord. Never use the cord for carrying, pulling or unplugging the machine. Keep the cord away from heat, oil, sharp edges and moving parts. Damaged or entangled cords increase the risk of electric shock.



WARNING!

This machine produces an electromagnetic field during operation! This field may, under some circumstances, interfere with active or passive medical implants! To reduce the risk of serious or fatal injury, we recommend persons with medical implants consult their doctor and medical implant manufacturer before operating this product!

Vibration and noise reduction

To reduce the impact of noise and vibration emissions, limit the time of operation, use low-vibration and low-noise operating modes, as well as wear personal protective equipment (PPE).

Take the following points into account to minimise the vibration and noise exposure:

- Only use the machine as intended by its design and these instructions.
- Ensure that the machine is in good condition and well maintained.
- Use the correct cutting device for the machine and ensure they are in good condition.
- Keep a tight grip on the handles/gripping surfaces.
- Maintain this machine in accordance with these instructions and keep it well lubricated (where appropriate).
- Plan your work schedule to spread any high vibration machine use across a longer period of time.

Warnings Symbols



Caution/Warning.



Read operator's manual.



There is a risk that some objects could be thrown out by the machine. Keep bystanders away.



Rotating parts may cause serious injury. Make sure the blades come to a complete stop before transporting the machine or before inspecting, cleaning, or conducting any other maintenance.



Beware of sharp blades. Blades continue to rotate after the motor is switched off. Remove the plug from the mains before maintenance or if the cord is damaged.



Keep the flexible supply cord away from cutting means.



Disconnect the mains plug if the cord becomes damaged or entangled.



Do not operate or expose the product to rain or wet conditions.



Wear eye protection. Wear hearing protection.



Guaranteed sound power level value in 93dB.



Recycle unwanted materials instead of disposing of them as household waste. All tools, cables and packaging should be sorted, taken to the local recycling centre and disposed of in an environmentally-friendly way.



The product complies with the applicable European directives and an evaluation method of conformity for these directives was done.



Class II equipment.

In The Box

Parts

1. Right handle
2. Left handle
3. Frame
4. Fixing nuts and bolts x 4
5. Cord clips x 2
6. Screws x 4
7. Middle handle
8. Motor housing
9. Lower handle
10. Protection guard
11. Blades

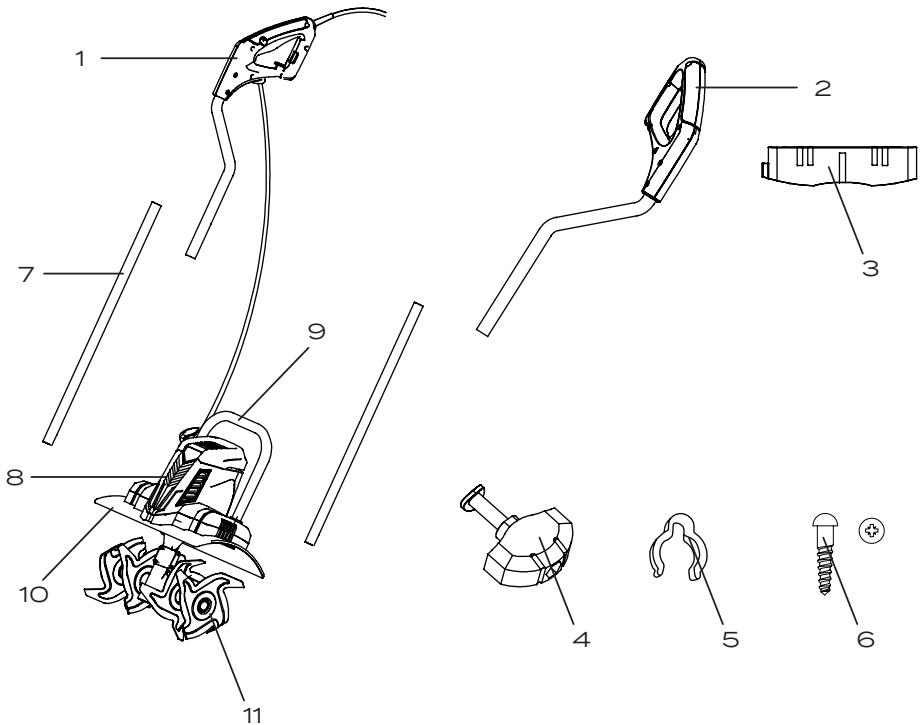

Assembly



WARNING! Always take care when removing the packaging to prevent causing damage to the machine.

1. Remove all parts of the electric tiller from the box and carefully remove all packaging. Take care not to lose any instructions which may be affixed to the parts. These provide important information which will be required when assembling the electric tiller.
2. Keep all packaging until the electric tiller is fully assembled and has been operated successfully.

NOTE: Always recycle the packaging in accordance with local recycling schemes.

Assembling the frame

Slide the right handle (1) and the left handle (2) into the frame (3). Secure the frame to the Left and Right-hand Grips with the screws provided.

NOTE: Use a Phillips-head screwdriver. Aligning the holes may be difficult; we recommend fastening one hand grip at a time to the frame.

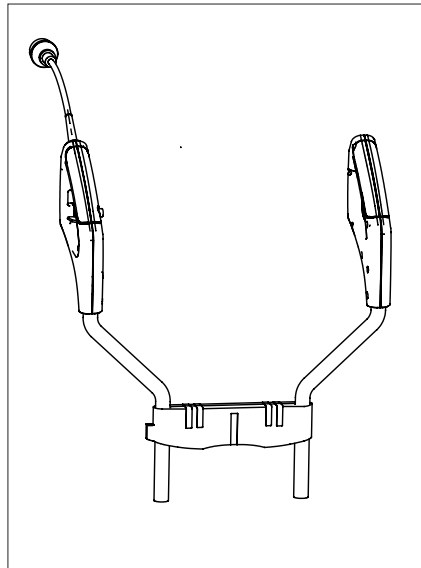
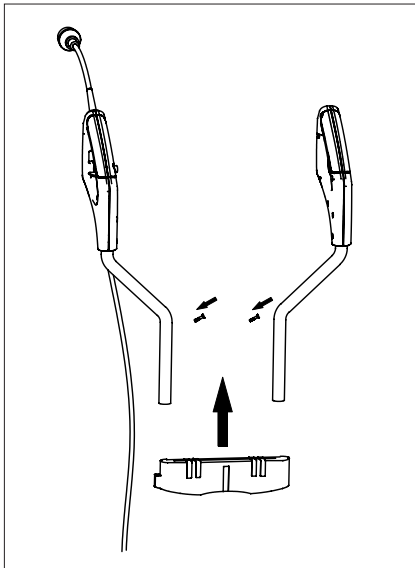

Assembling the handles

Align the upper handle frame with the middle handle. Use the nuts and bolts to fix the upper and middle handles firmly together.

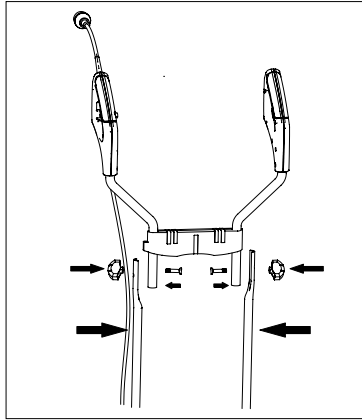

Align the middle handle frame with the lower handle. Use the nuts and bolts to fix the middle and lower handles firmly together.

NOTE: Make sure that the control handle is on the side of the cable holder of the connectors.

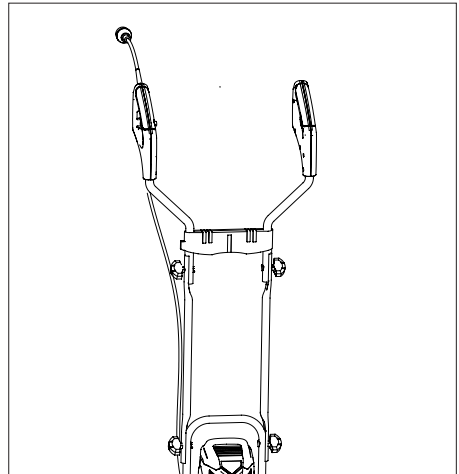
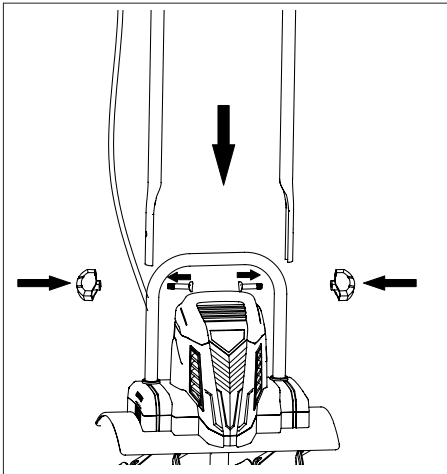

Clamping the cable with cable clip

Clamp the cable in the cable clip and fasten this to the bar.

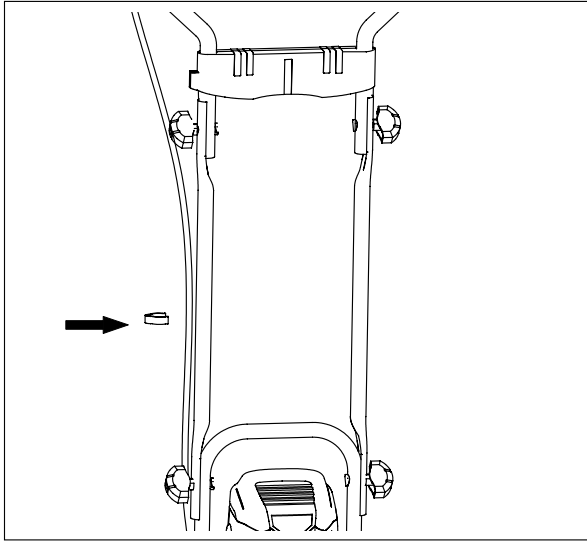

Preparation

Preparing to operate the electric tiller



WARNING! Read all of the instructions in this manual before connecting the machine to a power supply.



WARNING! If the insulation on a power cable or extension lead is found to be cut or damaged, do not touch it! Disconnect from the power supply immediately and have the damaged cable replaced by an authorised service agent.



WARNING! If operating the appliance in a damp location is unavoidable, use a residual current device (RCD) protected supply. Use of an RCD reduces the risk of electric shock.



WARNING! Use only extension cords suitable for outdoor use, preferably with a high visibility cable colour.

Always unwind all extension cables fully, as coiled cables can overheat and reduce the efficiency of your product.

NOTE: For extension cables up to 15 metres, use a wire cross section of 1.5mm². For extension cables over 15 metres but less than 40 metres, use a wire cross section of 2.5mm².



WARNING! This product is designed to operate on 230-240 VAC 50Hz. The voltage and current must comply with the information on the ratings label!



WARNING! Make sure the on/off switch is in its 'OFF' position.

Connecting the extension cord to a suitable socket

Double the extension cord about a foot from the end. Push the loop through the hole on the rear safe guard and hook the loop over the cord restrainer. Gently pull on the cord to ensure that it is firmly attached at the handle. Connect the cable to a proper socket.



WARNING! Always wear safety gloves when doing any work on the electric tiller.



WARNING! Always unplug the power cord from the power source before doing any work on the electric tiller.

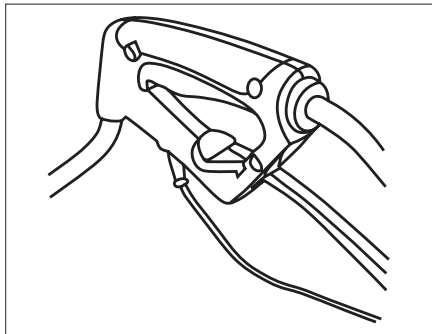

Switch on/off

NOTE: For your safety, this machine is equipped with a double switch system. This system prevents starting the machine inadvertently. You must press the switch button (A) firstly, and then hold the switch trigger (B).

Switching on

1. Press the lock button (A).
2. Hold the switch trigger (B) and release the switch button (A).

Switching off

Release the switch trigger (B).

NOTE: Never attempt to hold the switch trigger without pressing the lock button first!

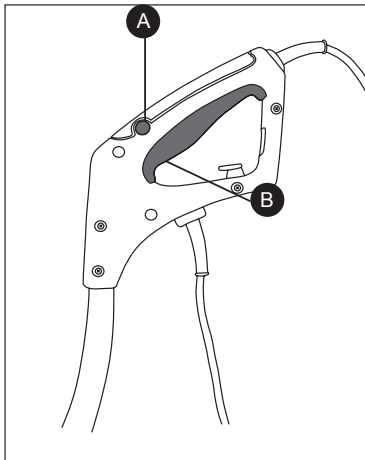

Operation

Operating



WARNING! Do not touch the gearbox, as it may become hot during operation.



WARNING! Always keep a firm grip on the machine with both hands and watch your feet; the blades may cause an accident. Take care when moving backwards to prevent tripping!



WARNING! To avoid damage to the machine:

Never lift or drag the machine with the motor running.

Lift the machine when moving it over hard surfaces, such as tiles or steps.



WARNING! Before switching the machine on, make sure that it is not touching any other objects and hold it firmly in both hands.

NOTE: After working with the machine, switch it off. To transport it, disconnect from the mains and wait for the blades to stop moving.

1. Walk the machine through the soil at normal pace and in as straight a line as possible.
2. Always work away from the mains socket. Make sure that the cable is kept well away from the working area.
3. Overload Protection: The motor will cut out immediately if overloaded. The machine cannot be used again until it has completely cooled down.

Maintenance and Repair

Maintenance and Repair



WARNING! Always switch the product off and let the product cool down before performing inspection, maintenance and cleaning work!

If you need to replace the fitted plug, then follow the instructions below.

IMPORTANT: The wires in the mains lead are coloured in accordance with the following code:

Blue – Neutral / Brown – Live

As the colours of the wire in the mains lead of this product may not correspond with the coloured markings identifying the terminals in your plug, proceed as follows. The blue wire must be connected to the terminal marked 'N' or coloured black. The brown wire must be connected to the terminal marked 'L' or coloured red.

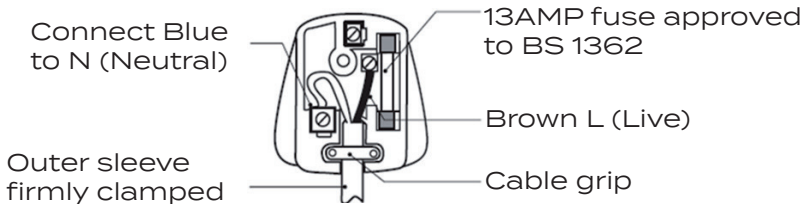

WARNING!

Never connect live or neutral wires to the earth terminal of the plug.

General

1. Clean the product with a slightly damp cloth and pH-neutral soap. Use a brush for areas that are hard to reach.
2. In particular, clean the air vents after every use with a cloth and brush.
3. Remove stubborn dirt with high pressure air (max. 3 bar).
4. Check for worn or damaged parts. Replace worn parts as necessary or contact an authorised service centre for repair before using the product again.

5. Regularly check for obvious defects, such as loose, dislodged or damaged cutting devices, loose fixings and worn or damaged components.
6. Check that covers are undamaged and correctly fitted. Carry out necessary maintenance or repairs before using the product.

Cutting Device



WARNING! Wear safety gloves when working on the cutting blades!



IMPORTANT! The machine is fitted with four tine wheels (blades) that can easily be changed in pairs. Both of the tine wheel pairs can be fitted on the left or right, as required. Purchase the blades from an authorised service centre.



WARNING! Make sure that the blades (d) are set to their proper turning direction. NOTE: The arrows on the gearbox and blades should point the same way.

1. Unscrew the hex bolt (b) and the self-locking nut (a) on the tine wheel pair (d).
2. Slide the tine wheel pair off the driveshaft (c).
3. Clean the driveshaft with biological oil.
4. Slide the new blades onto the driveshaft with the holes on the axles aligned to the holes on the driveshaft (c).
5. Slide the hex bolt (b) through the hole and tighten on the self-locking nut (a).

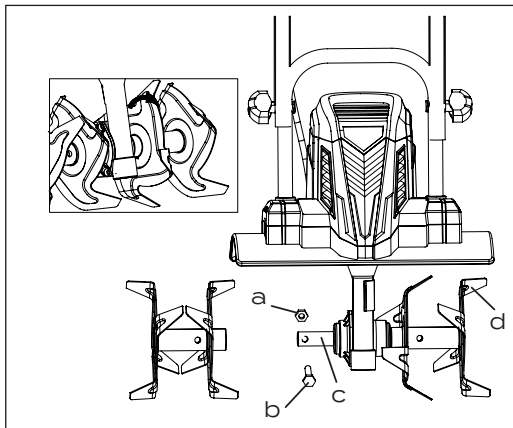

Storage

1. Clean the product as described above.
2. Store the product and its accessories in a dark, dry, frost-free, well-ventilated place.
3. Always store the product in a place that is inaccessible to children. The ideal storage temperature is between 10 and 30°C.
4. We recommend using the original packaging for storage, or covering the product with a suitable cloth or enclosure to protect it against dust.

Transportation

1. Switch the product off and disconnect it from the power supply before transporting it anywhere.
2. Always carry the product using its gripping surfaces.
3. Protect the product from any heavy impact or strong vibrations which may occur during transportation in vehicles.
4. Secure the product to prevent it from slipping or falling over.

Troubleshooting

General Troubleshooting



WARNING! Only perform the steps described within these instructions! All further inspection, maintenance and repair work must be performed by an authorised service centre or a similarly qualified specialist if you cannot solve the problem yourself!

Suspected malfunctions, disturbances or damages are often due to causes that the user can resolve themselves; therefore, check the product issues using this section. In most cases, the problem can be solved quickly.

Fault	Possible Cause	Solution
Product does not start	<ol style="list-style-type: none">1. Not connected to power supply2. Power connection is loose3. Other electrical defect to the product	<ol style="list-style-type: none">1. Connect to power supply2. Connect the power supply securely3. Check by a specialist electrician
Product does not reach full power	<ol style="list-style-type: none">1. Extension cord not suitable for operation with this product2. Power source (e.g. generator) has too low voltage3. Air vents are blocked	<ol style="list-style-type: none">1. Use a proper extension cord2. Connect to another power source3. Clean the air vents
Unsatisfying result	<ol style="list-style-type: none">1. Cutting blades worn	<ol style="list-style-type: none">1. Replace or sharpen blades

Technical Data

Technical Data Table

Property	Value
Model no.	TLEGO8CHR
Motor voltage	230-240V~/50Hz
Power input	1050W
No-load speed	390rpm
Working width	360mm
Max. working depth	180mm
Net weight	8kg
Measured sound pressure level	80.4dB(A), K=3dB(A)
Measured sound power level	89.95dB(A), K=1.4dB(A)
Guaranteed sound power level	93dB(A)
Vibration (m/s ²)	1.582m/s ² K=1.5m/s ²

The sound values have been determined according to noise test code given in EN 709, using the basic standards EN ISO 11094 and EN ISO 3744.

The sound intensity level for the operator may exceed 80dB(A) and ear protection measures are necessary.

The declared vibration value has been measured in accordance with a standard test method (according to EN 709) and may be used for comparing one product with another. The declared vibration value may also be used in a preliminary assessment of exposure.



WARNING! The vibration emission value during actual use of the machine can differ from the declared value, depending on the ways in which the machine is used. Identify safety measures to protect the operator that are based on an estimation of exposure in the actual conditions of use (taking account of all parts of the operating cycle, such as the times when the machine is switched off and when it is running idle, in addition to the trigger time).

For health & safety reasons, we should include the HAVS warning - attached.



WARNING! This machine may cause Hand-Arm Vibration Syndrome (HAVS) if its use is not adequately monitored and managed.

Preventative measures include, among others, regular maintenance and care of the product and cutting attachments, keeping hands warm and periodical breaks, as well as proper planning of work processes.

Disposal

The tiller and its accessories are made of various recyclable materials. Dispose of the tiller in accordance with your local recycling regulations, not with household waste.

Getting Help

Our dedicated UK-based customer helpline is open 7 days a week to assist you with assembly, parts queries and technical support. We are open during office hours but you can always send an email via **support@coreservice.co.uk**. Our experts are here to get you back enjoying your garden in no time.

For useful assembly, starting and maintenance videos, and for ordering spares, please visit **www.coreservice.co.uk**.

Calling our service does not affect your statutory rights.

Warranty

This product is covered by a 2 year warranty.

The warranty covers any manufacturing defect in materials, workmanship and finish.

Any claim under this warranty must be made by going to your nearest Homebase store, taking your proof of purchase with you, and claims must be made within 2 years of the date of purchase.

We will offer you a free repair of the item where this is possible, or a replacement or a refund. Your statutory rights remain unaffected, in particular any rights you may have under the Consumer Rights Act 2015.

This warranty is given by HHGL Limited, MK9 1BA, HHGL (ROI) Limited, DO2 X576.

Please note: This warranty does not apply to products misused or neglected and only covers domestic use. It does not apply to commercial use of the product. In addition, the warranty will be void for the following reasons: Any damage resulting from product misuse or product neglect.