

CHALLENGE 250W Grass Trimmer

Original Manual

N1F-GT-220/250-C

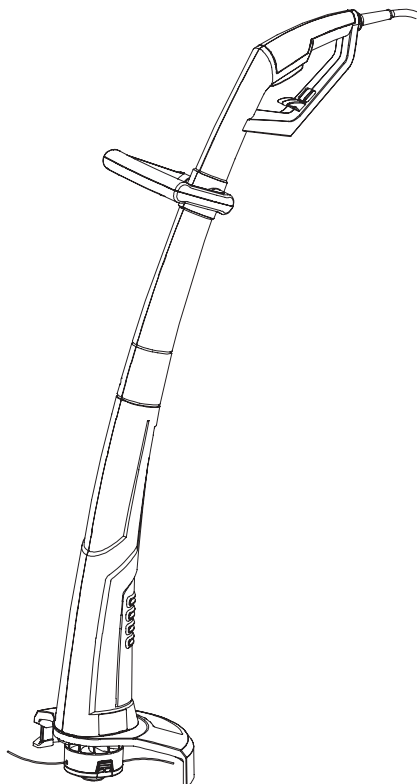

challenge[®]

Important - Please read these instructions fully before starting assembly and using.

These instructions contain important information that will help you get the best from your grass trimmer, ensuring it is assembled correctly and safely.

If you need help or have damaged or missing parts, call the Customer Helpline on 01904 727508 prior to returning product to store. SAN NO.:0321/8014/33ZB

Contents

Introduction.....	3
Safety Information	3
Parts list	12
Assembly.....	13
Operation.....	15
Maintenance and Storage	17
Troubleshooting.....	19
Technical Data	20
Recycling and Disposal.....	21
Guarantee	22

Produced in China.

Argos Limited

489-499 Avebury Boulevard, Milton Keynes, MK9 2NW.

Argos (N.I.) Ltd, Forestside Shopping Centre,
Upper Galwally, Belfast, United Kingdom, BT8 6FX.

Argos Distributors (Ireland) Limited,
Unit 7, Ashbourne Retail Park, Ballybin Road,
Ashbourne, County Meath, Ireland.

Introduction

Introduction

Thank you for purchasing a CHALLENGE grass trimmer..

We would you like to be completely satisfied with your new product and hope you will enjoy using this tool for many years.

Your CHALLENGE Grass Trimmer has been designed for cutting grass and similar soft vegetation in private and hobby garden areas which are not accessible with a grass trimmer.

The device is not allowed to be used in public gardens, parks, sports centers or at roadsides as well as agriculture and forestry.

Safety Information

Important - Please read these instructions fully before starting assembly

General Power Tool Safety Warnings

 **Read all instructions.** Failure to follow all instructions listed below may result in electric shock, fire and/or serious injury. The term “power tool” in all warnings listed below refers to your mains operated power tool.

- 1. Read the instruction carefully.** Be familiar with the controls and the correct use of the appliance. Read and understand the operator’s manual and observe the warnings and instruction labels affixed to the appliance.
- 2. Users.** Never allow children, persons with reduced physical, sensory or mental capabilities or lack of experience and knowledge or people unfamiliar with these instructions to use the machine, local regulations may restrict the age of the operator.
- 3. Use appropriate tool.** This device is only intended for cutting grass and soft vegetation outdoors and only designated for use on private

Safety Information

Important - Please read these instructions fully before starting assembly

General Power Tool Safety Warnings

property. Do not force small tools or attachments to do the job of a heavy duty tool.

4. **Keep work areas clean.** Cluttered areas can cause accidents.
5. **Consider work area environment.** Do not expose the tool to high humidity or rain. Do not use the tool in damp and wet conditions. Keep the work area well lit. Do not use the tool where there is a risk of causing fire or explosion, e.g. in the presence of flammable liquids and gases.
6. **Keep all bystanders, children, and pets away.** The operator or user is responsible for accidents or hazards occurring to other people or the property.
7. **Dress appropriately.** Do not wear loose clothing, hair or jewelry, as these can be caught in moving parts. Preferably wear non-slip footwear when working outdoors. Wear protective hair covering to keep long hair out of the way.
8. **Head protection.** Always use safety glasses and gloves. Use a face or dust mask whenever the operations may produce dust or flying particles. Wear ear protection whenever the sound level seems uncomfortable.
9. **Do not overreach.** Keep proper footing and balance at all times.

Safety Information

Important - Please read these instructions fully before starting assembly

General Power Tool Safety Warnings

- 10. Stay alert, watch what you are doing.** Use common sense when operating the appliance. Do not operate the tool when you are tired.
- 11. Grip the tool securely.** Operator should have one hand on the main handle, the other on the front handle. Keep finger off trigger until ready to use.
- 12. Remove adjusting keys and wrenches.** Always check that adjusting keys and wrenches are removed from the tool before operating the tool.
- 13. Risk of cut.** Do not touch or try to stop the cutting lines when they are moving.
- 14. Disconnect the plug.** Disconnect plug from the tool when not in use or when servicing or cleaning.
- 15. Check for damaged parts.** Before further use, carefully check the tool for damage. Check for alignment of moving parts, binding of moving parts, breakage of parts, mounting and any other condition that may affect its operation. Do not use the tool if any parts are damaged or defective. Have any damaged or defective parts repaired or replaced by an authorized service agent. Never attempt any repairs yourself.
- 16. Avoid unintentional starting.** Do not carry the tool without disconnect the plug and be sure the tool is switched off.

Safety Information

Important - Please read these instructions fully before starting assembly

General Power Tool Safety Warnings

- 17. Use an extension cord suitable for outdoor use when operating a power tool outdoors.** Use a cord suitable for outdoor use reduces the risk of electric shocks.
- 18. To connect the machine only to supply circuit protected by a residual current device (RCD) with a tripping current of not more than 30mA.**
- 19. Store idle tools.** When not in use, tools should be stored in a dry, locked-up place out of reach of children.
- 20. Maintain tools with care. Keep tools clean and in good condition for better and safer performance.** Follow the instructions for maintenance and changing accessories. Keep handles and switches dry, clean and free from oil and grease.
- 21. Have your tool repaired by an authorized service agent.** This tool is manufactured in accordance with the relevant safety regulations. To avoid danger, electrical appliances must only be repaired by qualified technicians.

Safety Information

Important - Please read these instructions fully before starting assembly

Additional safety warnings for your grass trimmer



WARNING!

Do not use any attachments or accessories not recommended by the manufacturer of this tool.

The use of attachments or accessories not recommended can result in serious personal injury.

1. Wear protective glasses or goggles;
2. Never allow children or people unfamiliar with the instructions to use the machine;
3. Stop using the machine while people, especially children, or pets are nearby;
4. Only use the machine in daylight or good artificial light;
5. Before using the machine and after any impact, check for signs of wear or damage and repair as necessary;
6. Never operate the machine with damaged guards or without the guards in place;
7. Keep hands and feet away from the cutting means at all times and especially;
8. Take care against injury from any device fitted for trimming the filament line length. After extending new cutter line always return the machine to its normal operating position before switching on;
9. Never fit metal cutting elements;

Safety Information

Important - Please read these instructions fully before starting assembly

Additional safety warnings for your grass trimmer

10. Never use replacement parts or accessories not provided or recommended by the manufacturer;
11. Always ensure that ventilation openings are kept clear of debris;

Electrical safety



WARNING!

Read these safety instructions thoroughly before connecting this product to the mains supply.

1. Before switching on, make sure that the voltage of your electricity supply is the same as that indicated on the rating plate. This product is designed to operate on 230-240VAC 50Hz. Connecting it to any other power source may cause damage.
2. This product may be fitted with a non-rewireable plug. If it is necessary to change the fuse in the plug, the fuse cover must be refitted. If the fuse cover becomes lost or damaged, the plug must not be used until a suitable replacement is obtained.

If the plug has to be changed because it is not suitable for your socket, or due to damage, it should be cut off and a replacement fitted, following the wiring instructions shown below.

The old plug must be disposed of safely, as insertion into a 7 amp socket could cause an electrical hazard.

Safety Information

Important - Please read these instructions fully before operation or maintenance

Electrical safety

WARNING!

A 7amp fuse must be fitted. The use of a high sensitivity residual current device (RCD) is recommended to provide personal protection against harmful electric current.

Plug replacement (for UK only)

If you need to replace the fitted plug, then follow the instructions below.

IMPORTANT: The wires in the mains lead are coloured in accordance with the following code:

Blue – Neutral Brown – Live

As the colours of the wire in the mains lead of this product may not correspond with the coloured marking identifying the terminals in your plug, proceed as follows. The wire, which is coloured blue, must be connected to the terminal, which is marked with N or coloured black.

The wire, which is coloured brown, must be connected to the terminal, which is marked L or coloured red.

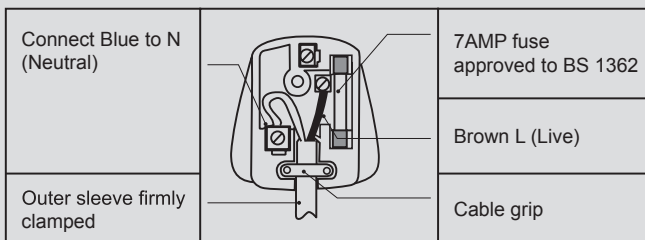

Safety Information



WARNING! Never connect live or neutral wires to the earth terminal of the plug.



WARNING!

Do not use two-core extension cords or reels on power tools with an earth path.

Use only extension cords suitable for outdoor use, preferably with a high visibility cable colour. Always unwind all extension cables fully, coiled cables can overheat and reduce the efficiency of your product.

For extension cables up to 15metres , use a wire cross section of 1.5mm².

For extension cables over 15 meters but less than 40 meters, use a wire cross section of 2.5 mm².

If the insulation on a power cable or extension lead is found to be cut or damaged, do not touch it! Disconnect the power supply immediately and have the damaged cable replaced.

Do not repair damaged cables.

Always follow the manufacture's instructions.

Safety Information

Warning Symbols



Read the instruction manual before use.



Wear ear protection.



Wear eye protection.



Wear dust mask.



Do not expose and operate the tool in rain.



Objects thrown by the product could hit the user or other bystanders. Always ensure that other people and pets remain at a safe distance from the product when it is in operation. In general, children must not come near the area where the product is in operation.



Remove the plug from the mains supply immediately if the cable is damaged or cut.



Double insulation.



Recycle unwanted materials instead of disposing of them as waste. All tools, hoses and packaging should be sorted, taken to the local recycling centre and disposed of in an environmentally safe way.



Guaranteed Sound power level data (95dB) in accordance with Directive 2000/14/EC.



Conforms to relevant EU regulatory requirements.



Conforms to relevant UK regulatory requirements.

Parts list

Parts description

- | | |
|-------------------|--------------------|
| ① Cable restraint | ⑤ Safety guard |
| ② On/off switch | ⑥ Auxiliary handle |
| ③ Upper shaft | ⑦ Trimmer head |
| ④ Motor housing | |

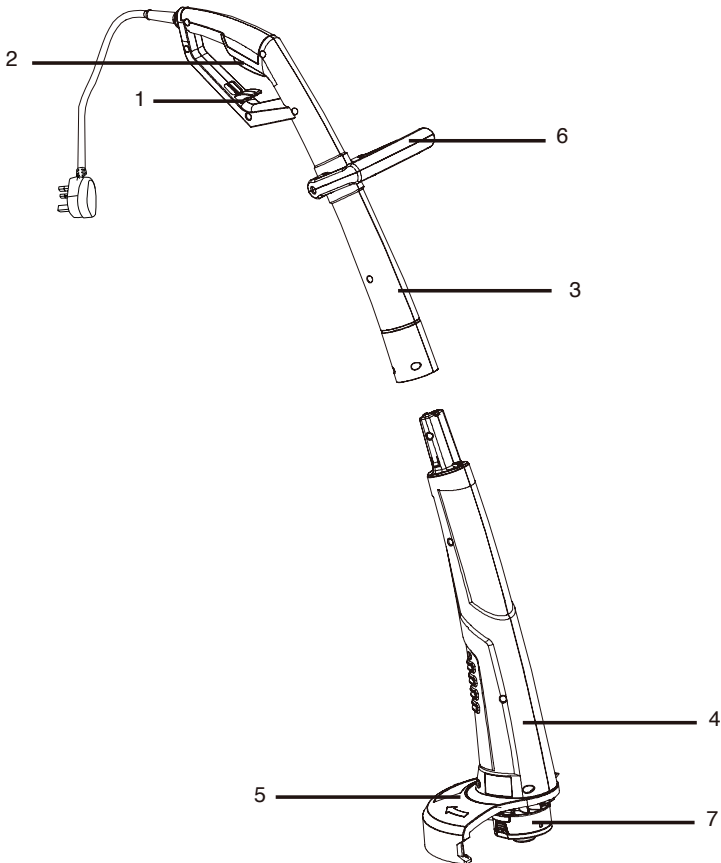

Assembly

Preparing to assemble the grass trimmer



WARNING!

- Always take care when removing the packaging to prevent damage to you or to the grass trimmer.
- Keep the carton in guarantee time. Always recycle the packaging in accordance with local recycling schemes.

Assemble the trimmer head

Insert the motor housing into the upper shaft, making sure the two parts are locked-in.

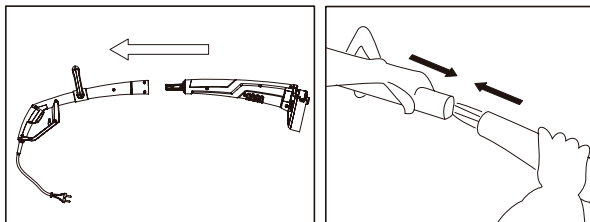

Assemble the safety guard



WARNING!

Do not use the product without fitting the guard.

Push the line guard over the cutting line spool and onto the trimmer head.

Make sure that the cutting line is not trapped under the line guard. Make sure that the sides are located into the grooves on the trimmer head.

Secure the safety guard with screw provided.

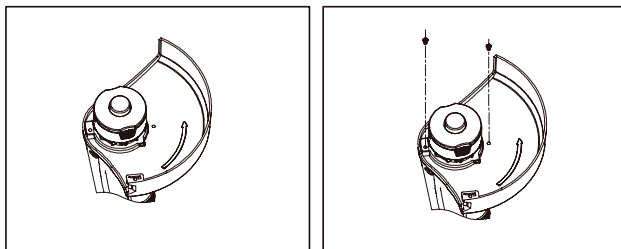

Assembly

Assemble the safety guard



WARNING!

Take care to have a look at the yellow warning label and rip off before use. Take great care when doing this as there is a very sharp line blade (14) on the guard. Do not touch the blade.

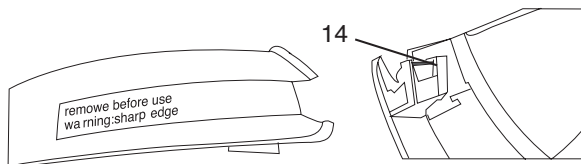

Fit the auxiliary handle

Locate the auxiliary handle to the bracket. Take care of its orientation.

Insert the bolt through the bracket and the handle then screw into the captivated nut. Tighten the screw with tool.

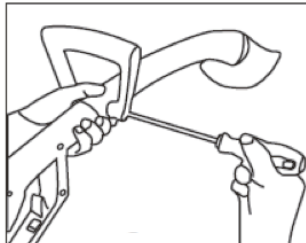
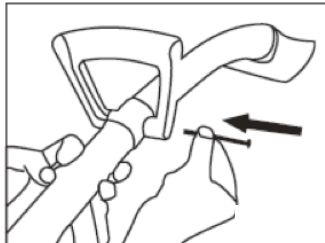

Mains supply cable strain relief

To prevent excessive strain on the cable connections, the grass trimmer is fitted with a cable restraint.

Before switching on, push a loop of cable through the space in the handle and secure it over the cable restraint.

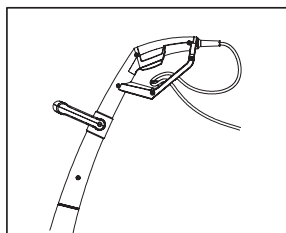

Operation

Switch ON/OFF

Press the on/off switch, your switch is now on. To switch off, simply release the on/off switch.

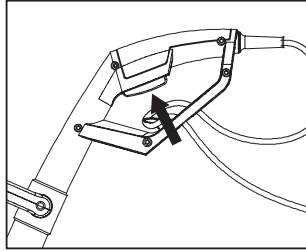

Cutting grass



WARNING!

Always wear eye protection. Never lean over the trimmer head. Rocks or debris can ricochet or be thrown into eyes and face and cause blindness or other serious injury.

When operating unit, check for the following:

Wear eye protection and heavy clothing.

Hold front handle with one hand and auxiliary handles with the other hand.

Keep unit below waist levels. Work only from your right to your left to ensure debris is thrown away from you.

Without bending over, keep line near and parallel to the ground (perpendicular when edging). Do not switch the machine on with the cutting head on or near material to be cut.

Ensure the cutting line is at full speed before contacting material to be cut.



WARNING!

Make sure that line is fed out before operation.

Make sure motor is up to full speed before trimming.

1. Let the trimmer run for a few seconds without touching the working area, and allow the trimmer to cut the line.
2. Use the trimmer at an angle of approximately 15 degree to the working area.
3. Swing the trimmer head from side to side.

Operation

Cutting grass



4. If the grass is very long cut in stages rather than trying to cut in one go. Do not overload your trimmer, take small cuts this will keep machine operating at high speed and will greatly improve cutting efficiency.

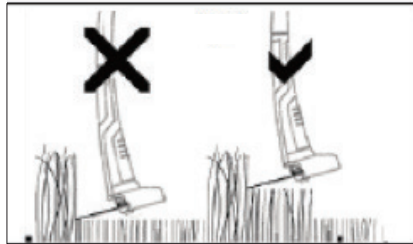

Manually feed the line

If required, line can be fed out manually. To operate, press and release manual line feed button, while gently pulling out the lines until the lines reach the line cutter.

When the required amount of line is fed out, gently pull on the second line (there is no need to press the manual line feed button again), If the line extends past the line cutter, too much line has been fed out.

If too much line is fed out, remove the spool cap and turn spool counter-clockwise until the line is at the desired length .

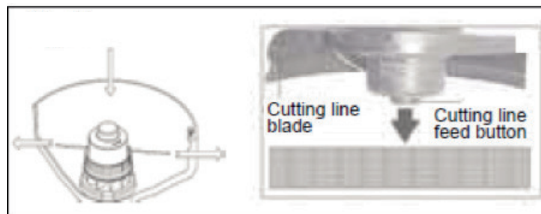

Maintenance and storage

Exchange the spool



WARNING!

Before cleaning, inspecting or repairing your unit, make sure the switch is off. Disconnect the plug from mains.

Press the release latch on the spool head cover and remove cover, pulling it straight off the cutting head assembly.

Pull the cutting head cover away from the spool holder.

Keep all areas of the cutting head cover and spool holder clean.

Replace the spool head cover, pressing firmly down towards the spool holder to ensure the cover is fully located.

Check that the cap is correctly fitted by trying to remove it without depressing the two latches.

Place new spool into cutting head with cut out areas of the spool in line with eyelets.

Release line from cleat and feed line through eyelet.

Refit the spool head cover.

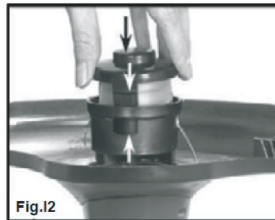
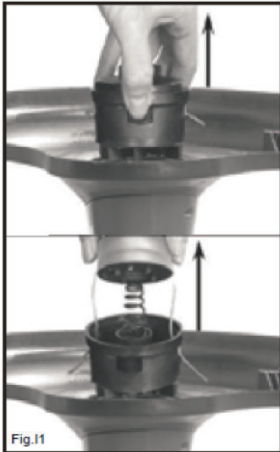

Maintenance and storage

Fit nylon line

Take approximately 4m of line. Insert line into the spool holes and wind line in the direction of the arrows on the top of spool.

Your trimmer is designed to use only line with a maximum diameter of 1.2mm.

Important! Leave approximately 100mm of line unwound and place into cleat.

Care should be taken to ensure that the line is neatly coiled on the spool.

Failure to do so will impair the efficiency of the automatic line feed.

Then fit the spool cap in exchange the spool part.

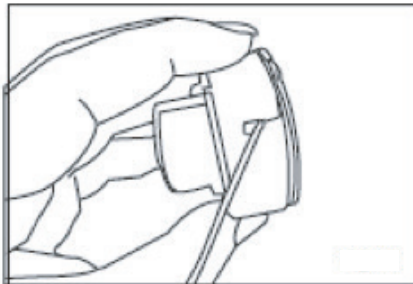
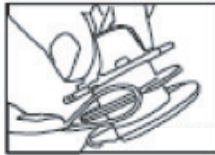

Clean and storage



Note! For your convenience it is recommended you buy spool and line complete.

1. Never use water or chemical cleaners to clean your power tool. Wipe clean with a dry cloth.
2. Always check the cutting head and guard before each use.
3. Always store your power tool in a dry place.
4. Keep the motor ventilation slots clean.
5. Have the unit professionally repaired should any damage parts.

Troubleshooting

General Troubleshooting



WARNING!

Before proceeding, unplug the tool.

Although your new grass trimmer is really easy to operate. If you do experience problems, check the following.

General Troubleshooting

- Check that the spool housing can rotate freely. Carefully clean it if necessary.
- Check that the cutting line does not protrude more than 9 cm from the spool housing. If it does, cut it off so that it just reaches the line trimming blade.

If the trimmer is not cutting properly

Check the condition of the cutting head, if the cutting line is too short or cutting head damaged.



Note: Do not use damaged cutting head.

Note: If a fault is suspected return the trimmer to an authorized dealer for repair.

Technical data

Technical Data Table

Model No.	N1F-GT-220/250-C
Rated voltage	230-240V~50Hz
Input power	250W
No load speed	12000/min
Cutting Width	220mm
Cutting line Diameter	1.2mm
Protection class	II
Machine Weight	2.1kg
NOISE AND VIBRATION DATA	
Measured sound power level L_{WA}	91dB(A), Uncertainty K= 0.74dB(A)
Calculated Guaranteed Sound Power Level L_{WA}	92dB(A)
The guaranteed sound power level (L_{WA})	95dB(A)
Vibrations	2.7m/s ² , K: 1,5m/s ²

Noise and vibration data



WARNING!

The sound values have been determined according to noise test code given in annex III of 2000/14/EC as amended by 2005/88/EC, using the basic standards ISO 11094:1991 and EN ISO 3744:1995.

The sound intensity level for the operator may exceed 80 dB(A) and ear protection measures are necessary.

The declared vibration value (according to EN 60335-1) has been measured in accordance with a standard test method and may be used for comparing one product with another. The declared vibration value may also be used in a preliminary assessment of exposure.



WARNING!

Depending on the actual use of the product the vibration values can differ from the declared total!

Adopt proper measures to protect yourself against vibration exposures! Take the whole work process including times the product is running under no load or switched off into consideration!

Proper measures include among others regular maintenance and care of the product and cutting attachments, keeping hands warm, periodical breaks and proper planning of work processes!

Recycling and Disposal

Disposal Instructions

1. Recycle unwanted materials instead of disposing of them as waste. All tools, hoses and packaging should be sorted, taken to the local recycling centre and disposed of in an environmentally safe way.
2. Recycle rather than dispose of unwanted material in landfill whenever possible. The machine must be delivered in rigid packaging to avoid damage during transportation. The packaging and the machine itself are manufactured from recyclable materials and should be disposed of accordingly.
3. Do not throw your clippings into a rubbish bin where it will dispose of clippings on your compost heap, alternating then with other garden material. The more thoroughly you chop the clippings beforehand, the more rapidly they will degrade. Alternatively, many communities provide a public collection point where you can dispose of your garden waste in an environmentally friendly manner.
4. Only dispose of electrical/electronic/battery items in separate collection schemes, which cater for the recovery and recycling of materials contained within. Your cooperation is vital to ensure the success of these schemes and for the protection of the environment.
5. Recycle packaging where facilities exist.
6. This symbol is known as the Crossedout Wheelie Bin Symbol. When this symbol is marked on a product or battery, it means that it should not be disposed of with your general household waste. Some chemicals contained within electrical/electronic products or batteries can be harmful to health.

Guarantee

Dear Customer,

In the unlikely event that your device develops a fault, please contact our Customer service department on the telephone number shown below.

1. These guarantee terms cover additional guarantee rights and do not affect your statutory warranty rights.

Claims must be accompanied by Proof of Purchase. This must be in the form of a Sales receipt or Bank statement and must show that the product has been purchased within 1 year prior to the claim, from the retailer that it was originally sold to.

2. Our guarantee covers problems caused by material or manufacturing defects, and will result in the repair of these defects or replacement of the device with a like for like or similar article. Please note that our devices have not been designed for use in commercial, trade or industrial applications. Consequently, the guarantee is invalidated if the equipment is used in commercial, trade or industrial applications or for other equivalent activities.

3. The following are also excluded from our guarantee:

A) Faults due to accidents, customer misuse, or unauthorized repairs

B) Consumable Parts such as blade

C) Failure due to lack of routine maintenance

D) Failure as a result of not using the equipment in accordance with the manual and safety instructions

4. The guarantee is valid for a period of 1 year starting from the purchase date of the device. Guarantee claims should be submitted before the end of the guarantee period within two weeks of the defect being noticed. No guarantee claims will be accepted after the end of the guarantee period. The original guarantee period remains applicable to the device even if repairs are carried out or parts are replaced. In such cases, the work performed or parts fitted will not result in an extension of the guarantee period, and no new guarantee will become active for the work performed or parts fitted. This also applies when an on-site Service is used.

5. Please keep your sales receipt in a safe place. If the defect is covered by our guarantee your device will either be repaired under the terms of guarantee or we will send you a replacement device. This device may be re-conditioned or Like for like replacement.