



# YARD FORCE®

FOR LIFE ON THE GO

HX FBQ1

GB

## CHARCOAL BBQ WITH BUILT-IN FAN

Original Instructions

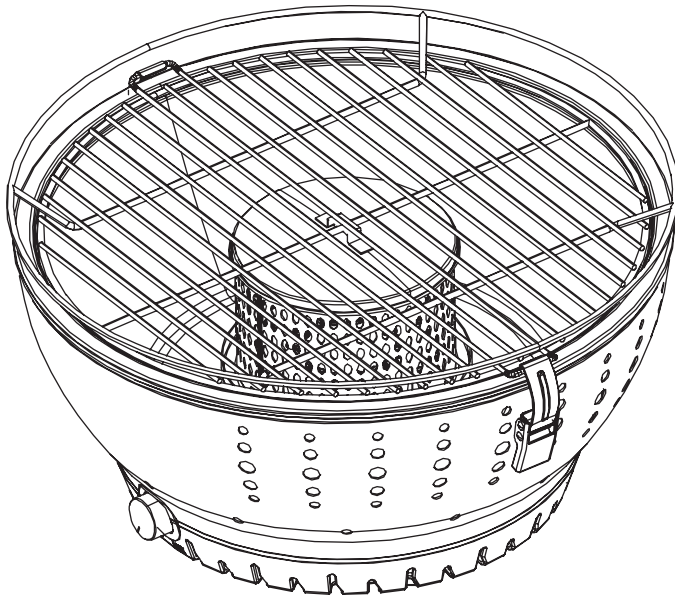

**READ & UNDERSTAND  
INSTRUCTION MANUAL**

Save all warnings and instructions for future reference.

# YARD FORCE

## HX FBQ1 Original Instructions

### CONTENT

General safety warnings	04
Symbols	10
Technical data	12
Description of product	12
Operation	13
Maintenance and storage	13
Declaration of conformity	15



## GENERAL SAFETY WARNINGS

### WARNING

Whilst every effort has been made in the manufacture of your BBQ to remove any sharp edges, care should be taken in handling to avoid any accidental injury.

1. Assembly time: approx. 60 mins.
2. Make sure the assembly instructions have been followed correctly.
3. Set the Charcoal BBQ in a suitable position, on a level surface away from areas likely to catch fire. The base of the Charcoal BBQ will get hot so ensure it stands on a suitable surface.
4. Always stand your Charcoal BBQ outdoors and on level ground away from trees and wooden fencing.
5. Ensure there is a least 1 metre clearance around all sides of the Charcoal BBQ. Keep away from fences, over hanging branches and other combustible materials.
6. Use Charcoal and a suitable lighting method.
7. Do not cook before the fuel has a coating of ash.
8. **WARNING!** This barbecue will become very hot , do not move it during operation.
9. Do not use indoors.
10. **WARNING!** Do not use spirit or petrol for lighting or relighting! Use only firelighters complying to EN1860-3!
11. **WARNING!** Keep children and pets away.

## GENERAL SAFETY WARNINGS

### Method 1. Charcoal & Lighting Fluid/ Gel

1. Set up your Charcoal BBQ in a safe place. Place enough charcoal in the charcoal grate to a depth of 3 - 5cm.
2. Taking care not to spill any liquid/ gel onto your hands or clothes. Apply carefully the lighting fluid/ gel over the charcoal.
3. If using lighting fluid, wait for 30 seconds to allow the liquid to soak into the charcoal.
4. Do not light the charcoal if you have spilt fluid or gel onto your clothes. Light the charcoal using a long taper or safety lighter. The charcoal will then burn for a period with flames.
5. When the flames die down, check the charcoal is beginning to glow red. If your coals are going out, you should open all the vents and allow to cool down before trying to apply more liquid. **CAUTION:** Apply carefully lighting fluid/ gel in small amounts. Over application can be dangerous.
6. Do NOT squirt liquid onto burning charcoal.
7. After lighting, the fire should be ready for cooking in 30-40 minutes, or when even grey ash is visible by day, or an even red glow is visible by night.

### Method 2. Lighting Blocks

1. Place three or four Lighting Blocks in the centre of the Charcoal grate and light with a match.
2. Place pieces of charcoal around each burning block. Add more charcoal as required, in a pyramid formation.

## GENERAL SAFETY WARNINGS

3. When burning is established, spread the fuel out evenly. After lighting, the fire should be ready, or when even grey ash is visible by day, or an even red glow is visible by night.
4. Make sure that the cooking grill is fully located into the grill supports so that the cross bar supports lock behind the retaining edges.
5. When the charcoal is alight, the smoke and flames have died down and the charcoal has an even layer of grey ash, rake the charcoal into a level layer in the hearth.
6. Small quantities of charcoal may be added on top of the charcoal layer prior to cooking to extend cooking time.
7. To help prevent food sticking, apply a tin coating of cooking oil on the grill prior to cooking.
8. To adjust the airflow using the air vent we recommend to use of a heat resistant glove.
9. ALWAYS WEAR OVEN GLOVES WHEN HANDLING THE CHARCOAL BBQ.
10. Recommend using Maximum 1.5kg of charcoal briquettes on the charcoal grate. Excess charcoal will make the BBQ too hot for cooking. The max loading weight of the side shelf is 4kg.
11. Ensure the barbecue has cooled down completely before removing the charcoal ash.

## GENERAL SAFETY WARNINGS

### Care and Maintenance

1. To make it easier to clean your Charcoal BBQ after use, line the firebowl with aluminium cooking foil, shiny side up. Remember to leave ventilation holes clear by piercing the foil where necessary. This process will lengthen the life of your Charcoal BBQ.
2. Charcoal is available in lump wood from (large irregular pieces) and as briquettes (uniformly sized pieces). Please use the charcoal complying to EN1860-2.
3. It is not advisable to completely fill the firebowl as the BBQ may become far too hot to cook successfully. As a guide ,a 3kg bag of charcoal briquettes should last for at least 2 full BBQ fires.
4. If the fires flares up due to dripping fat then douse the flames lightly with a fine water spray.
5. When you have finished using the Charcoal BBQ, never pour cold water directly on the coals to extinguish them as this may damage your Charcoal BBQ. Use old cinder, sand or a fine water spray.
6. Empty the bottom bowl of ashes when they are completely cold.
7. To clean your Charcoal BBQ, soak the cooking grill and tools in hot soapy water as soon as possible after use. Dry thoroughly and store in a dry place. Do not leave your Charcoal BBQ outside unprotected.

## GENERAL SAFETY WARNINGS

### Food Safety

1. Thoroughly defrost frozen meat and poultry in the refrigerator before cooking. Keep raw meat and poultry separate from cooked food.
2. Ensure that the grill is thoroughly cleaned before cooking and lighting the barbecue.
3. Always wash hands after handling raw meat and poultry before handling any ready to eat food.
4. Wipe and disinfect surfaces that have been in contact with raw meat and poultry.
5. When barbecuing meat and poultry, make sure the barbecue is really hot. Place the larger, thicker portions furthest away from the most intense heat to ensure thorough cooking without burning and turn regularly.
6. Use separate utensils for handling raw meat or poultry and cooked food on the barbecue, or wash them thoroughly between use.
7. To check whether meat, particularly poultry, is cooked, pierce the flesh with a skewer or fork: the juices should run clear. Ensure the product is piping hot throughout.

**Attention!** This BBQ will become very hot do not move it during operation. Do NOT use indoors.

Warning! Keep children and pets away!

Caution! Do not use spirit or petrol for lighting or re lighting! Use only firelighters complying to EN 1860-3

## GENERAL SAFETY WARNINGS

### Battery Safety

1. Batteries should be installed by an adult.
2. Never mix old and new batteries (replace all batteries at the same time).
3. Never mix alkaline, standard (Carbon Zinc) or rechargeable batteries.
4. Do not recharge non-rechargeable batteries.
5. Rechargeable batteries must be removed before recharging, and charged under adult supervision.
6. Remove batteries from product before extended storage or if exhausted.
7. Never try to dismantle batteries.
8. Do not short circuit the supply terminals.
9. Batteries may explode or leak if misused.
10. Do not dispose of batteries in a fire or BBQ.

### Carbon Monoxide Hazard

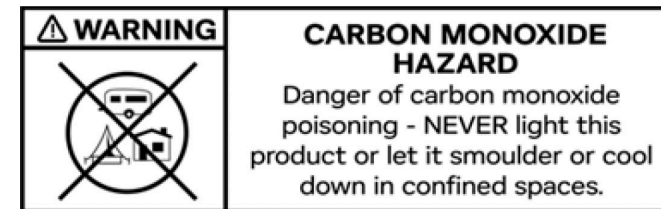

## SYMBOLS

### Safety symbols

The purpose of safety symbols is to attract your attention to possible dangers. The safety symbols and the explanations with them require your careful attention and full understanding. The symbol warnings do not, by themselves, eliminate any danger. The instructions and warnings they give are no substitutes for proper accident prevention measures.

**WARNING:** Be sure to read and understand all safety instructions in this operator's manual, including all safety alert symbols such as "**DANGER**," "**WARNING**," and "**CAUTION**" before using this tool. Failure to follow all instructions listed below may result in electric shock, fire and/or serious personal injury.

**SAFETY ALERT SYMBOL:** Indicates **DANGER**, **WARNING**, or **CAUTION**. May be used in conjunction with other symbols or pictographs.

### Symbol meaning

This page depicts and describes safety symbols that may appear on this product. Read, understand and follow all instructions on the machine before attempting to assemble and operate.

## SYMBOLS



To reduce the risk of injury, user must read instruction manual carefully.



Do not use the barbecue in a confined and/or habitable space e.g. houses, tent, caravans, motor homes, boats. Danger of carbon monoxide poisoning fatality.



The product complies with the applicable European directives and an evaluation method of conformity for these directives was done.



Conforms to relevant UK regulatory requirements

## TECHNICAL DATA

Model		HX FBQ1
Battery cell		4 x 1.5 V AA
Dimension		38x38x19 cm
Weight:		3.2 kg

## DESCRIPTION OF PRODUCT

### Parts description

1. Charcoal hook
2. Grill Grid
3. Charcoal Container Cover
4. Charcoal Container
5. Ignition Plate
6. Inner Bowl
7. Outer Bowl
8. Battery Case (Integrated with outer bowl)
9. Battery Case Cover
10. On/Off Switch for Heat Regulation with Light Indicator
11. Power Bank Cord Connector

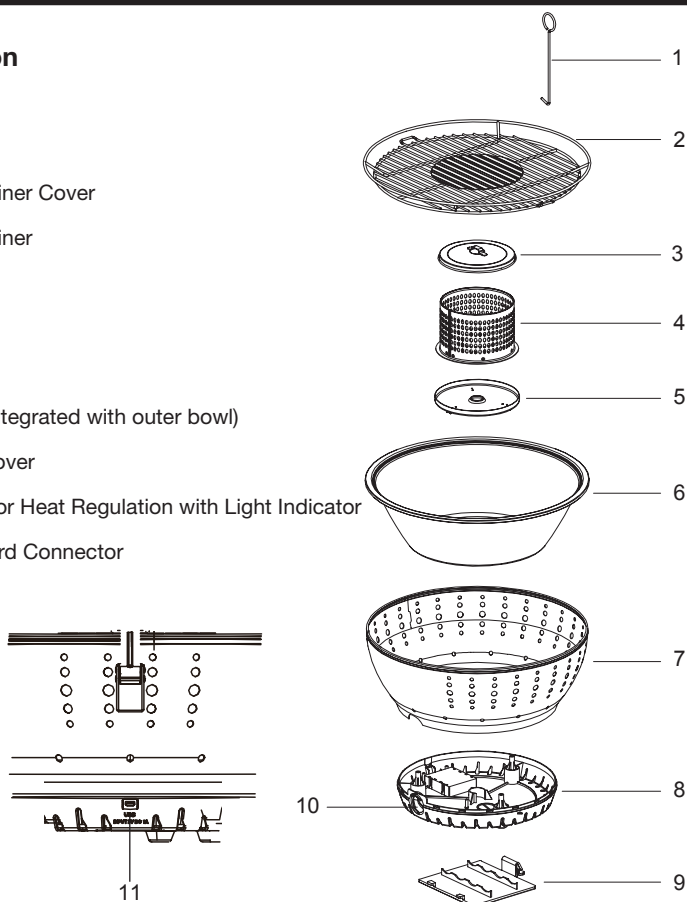

## OPERATION

### Preparation

Open the battery cover (9) with a Philips screwdriver and insert 4 x 1.5 V AA batteries (Do not provided with this product) into the battery case (8). Check that the batteries are correctly fitted. Replace the battery cover and fix it with a Philips screwdriver.

If the batteries run out during use, you can connect a power bank via the connector (11) and so continue barbecuing.

### Use

1. Place the inner bowl(6) into the outer bowl(7).
2. Fill the charcoal container(4) completely with charcoal. Put cover(3) on charcoal container(4).
3. Apply a circular layer of lighter gel on ignition plate(5), approx. 10 mm (0.4 inches) wide.
4. Place ignition plate(5) into inner bowl(6).
5. Turn on the Switch(10) on side of battery case(8). Turn it clockwise to maximum position.
6. Using a safety lighter, light gel until it burns.
7. Put the cover(3) on the filled charcoal container(4) and place container on ignition plate(5). Within a short period of time, the charcoal should start glowing.
8. Put the grill grid(2) on top of the inner bowl(6) and lock it with two latches.
9. After approx. 3-4 minutes, this grill is ready for use. Use the On/Off Switch for heat regulation(10) to regulate heat. The fan stays on during the entire barbecue session.

NOTE: DO NOT place burning charcoal outside charcoal container(4) to prevent heat injury.

## MAINTENANCE AND STORAGE

### Cleaning

Clean the barbecue after every use.

Allow the barbecue to almost cool completely so that it is still warm when you clean it.

Remove the barbecue rack. Lift out the charcoal holder and tray. Remove the reflector from the casing.

Wash the barbecue rack and reflector in warm water with a little washing-up liquid.

To remove burnt-on food, soak the rack in soapy water, and then scrub with a soft sponge or similar. Rinse with water and apply cooking oil before using again.

Empty the charcoal holder and remove any residual ash with a brush.

Wipe all parts thoroughly and reassemble the barbecue.

Wipe the outside of the barbecue with a wellwring cloth and then dry off with a dry cloth.

Store the barbecue in the carrying bag (13) in a dry, dust-free location out of direct sunlight.

Remove the batteries from the battery compartment if the barbecue is not going to be used for a prolonged period.

## MAINTENANCE AND STORAGE

### Battery Replacement

1. Using a suitably sized screw driver, remove the screw and take off the back cover.
2. Remove the old batteries and place new batteries into the compartment.
3. Batteries must be inserted with the correct polarity (+ and -).
4. Only use 1.5V AA batteries in this item.
5. Refit the cover and safety screws before using.
6. Dispose of any exhausted or used batteries responsibly, at a battery collection point if available.

## DECLARATION OF CONFORMITY

### To the provisions of Council Directives

We  
**MEROTEC GmbH**  
Otto-Brenner-Str. 8, 47877 Willich, Germany

Declare that the product:  
Description: Charcoal BBQ with built-in fan  
Model No. HX FBQ1/ DT 1002B

### Complies with the essential health and safety requirements of the following directives:

2009/48/EC Toy Safety - Directive  
2014/30/EU Electromagnetic Compatibility - Directive (EMC)  
2014/35/EU Low Voltage Directive (LVD)  
2011/65/EU Restriction of the Use of certain Hazardous Substances in Electrical and Electronic Equipment (RoHS)

### Standards and technical specification referred to:

EN 1860-1:2013/A1:2017	EN 62321-3-1: 2014
EN 60335-1:2012+A11+A13+A14+A15	EN 62321-4: 2014/ A1:2017
EN 60529: 1992/A2:2013	EN 62321-5: 2014
EN IEC 62115: 2020/A11:2020	EN 62321-6: 2015
EN ISO 9227	EN 62321-7-1: 2015
EN 55014-1: 2021	EN 62321-7-2: 2017
EN 55014-2: 2021	EN 62321-8: 2017
EN 62321-1: 2013	
EN 62321-2: 2014	

Authorized Signatory

Date: 15.01.2023

Signature: 

Place: Willich

Name: Ronald Menken  
General Manager

MEROTEC GmbH  
Otto-Brenner-Str. 8  
D-47877 Willich





# DECLARATION OF CONFORMITY

To the provisions of Council Directives

We

**SUMEC UK**

**Unit A&B Escrick Business Park Escrick, York YO19 6FD  
United Kingdom**

Declare that the product:

Description: Charcoal BBQ with built-in fan  
Model No. HX FBQ1/ DT 1002B

## **Complies with the essential health and safety requirements of the following directives:**

Toys (Safety) Regulations 2011

Electromagnetic Compatibility Regulations 2016

Electrical Equipment (Safety) Regulations 2016

The Restriction of the Use of Certain Hazardous Substances in Electrical and Electronic Equipment Regulations 2012

## **Standards and technical specification referred to:**

EN 1860-1:2013/A1:2017

EN 62321-3-1: 2014

EN 60335-1:2012+A11+A13+A14+A2

EN 62321-4: 2014/ A1:2017

EN 60529: 1992/A2:2013

EN 62321-5: 2014

EN IEC 62115: 2020/A11:2020

EN 62321-6: 2015

EN ISO 9227

EN 62321-7-1: 2015

EN 55014-1: 2021

EN 62321-7-2: 2017

EN 55014-2: 2021

EN 62321-8: 2017

EN 62321-1: 2013

EN 62321-2: 2014

Authorized Signatory

Date: 15.01.2023

Signature: \_\_\_\_\_



Place: York

Name: Mariana Hall

General Manager

SUMEC UK Co.,Ltd.

Unit A&B Escrick Business Park

Escrick, York YO19 6FD

United Kingdom

