

GB

ELECTRIC LAWN MOWER

Original Instructions



**READ & UNDERSTAND
INSTRUCTION MANUAL**



Save all warnings and instructions for future reference.

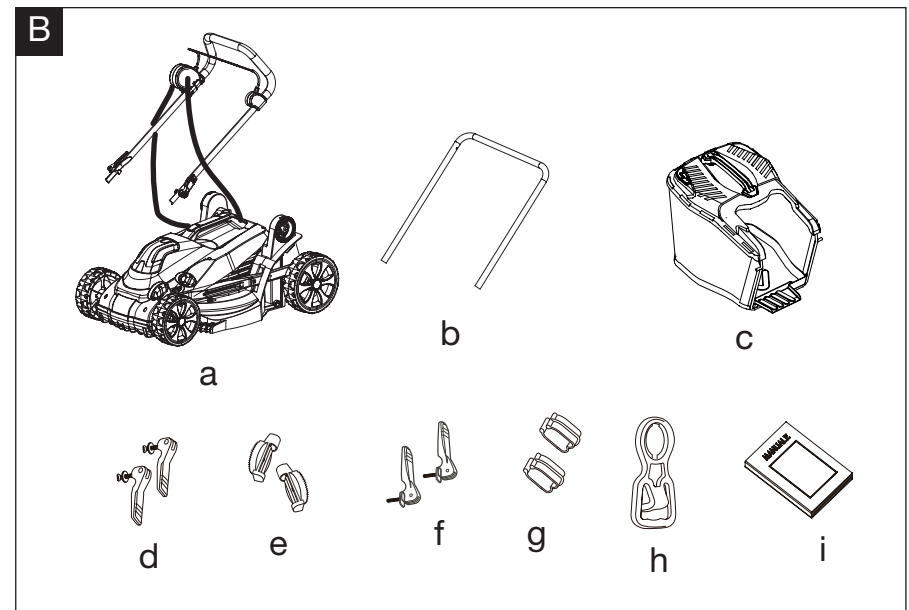
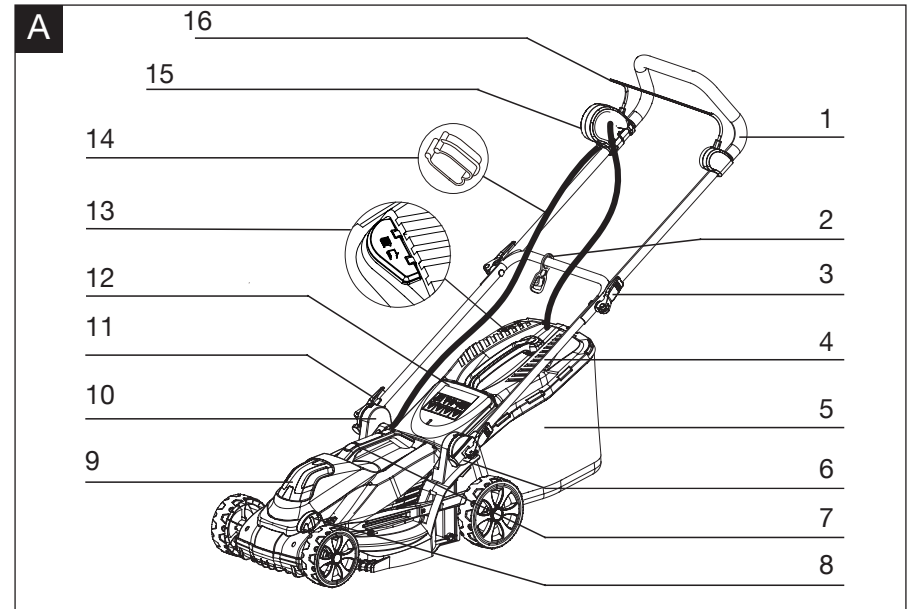

Read this manual carefully prior to assembling and operating the lawnmower. It is dangerous to operate this product without being familiar with these instructions. Keep this manual in a safe place and have it ready for future reference.

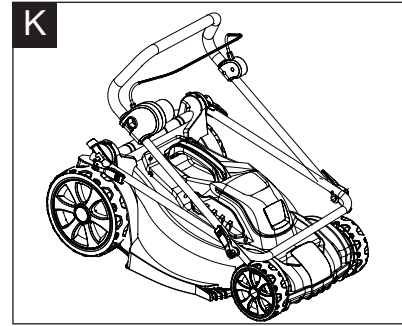
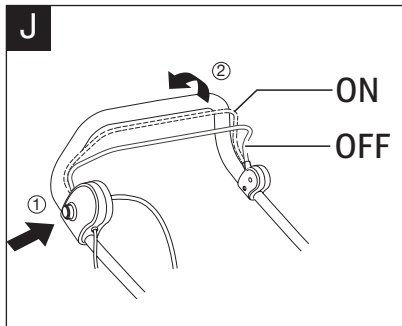
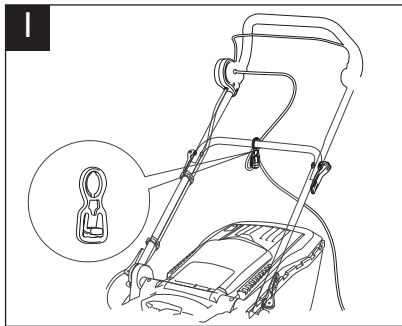
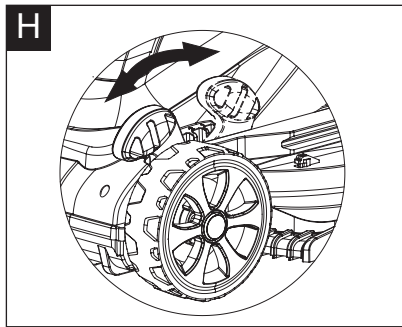
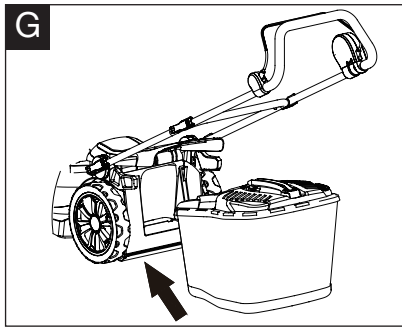
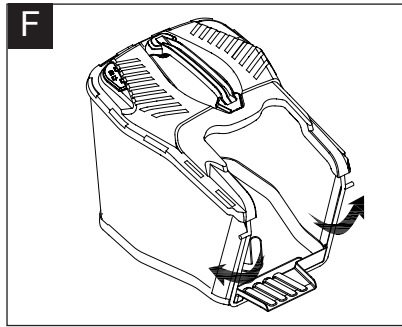
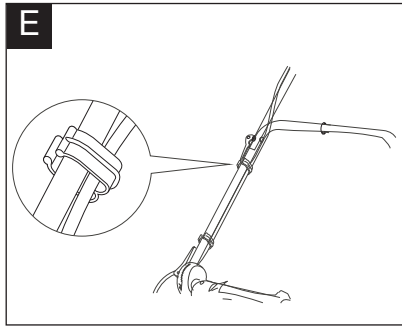
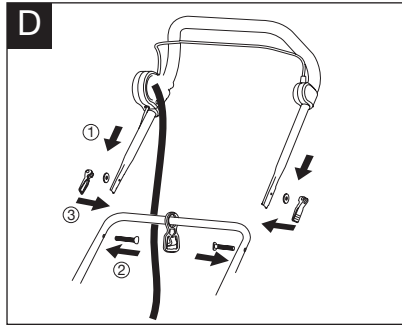
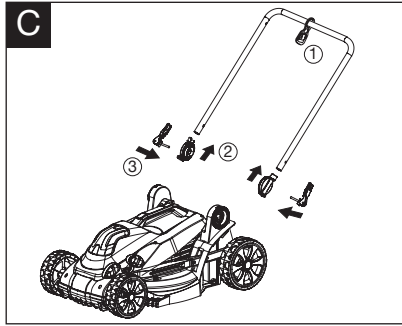

CONTENT

Intended use	07
General safety warnings	07
Symbols	11
Technical data	14
Description of product	15
Installation	16
Operation	17
Maintenance and storage	20
Troubleshooting	22
Declaration of conformity	23

INTENDED USE

The device is exclusively designed for mowing private lawns. The lawn must be dry and level. Wildflower meadows, uncultivated meadows and strongly overgrown lawns with high weeds (such as thistles) are not considered lawns.

This device is intended for private use only and is not suitable for commercial use. Use the device only as described in this operating manual. Any other use is improper and may lead to product damage or even personal injury. This device is not a toy.

The manufacturer or retailer assume no liability for damage caused by improper or incorrect use.

GENERAL SAFETY WARNINGS

This operating manual is part of the electric lawn mower (hereinafter also called "device"). It contains important information on how to set up and use the product.

Before using the device, read the operating manual carefully, in particular the safety instructions. Failure to follow this operating manual may lead to severe injuries or product damage.

This user manual is based on the standards and regulations that are valid within the European Union. Outside the EU, please also note the country-specific directives and laws.

Keep this operating manual for future reference. If you pass this device on to a third party, you must also supply this operating manual.

**IMPORTANT
READ CAREFULLY BEFORE USE
KEEP FOR FUTURE REFERENCE**

GENERAL SAFETY WARNINGS

Safety notes

Risk of electric shock!

Improper handling of the device, faulty electric installation or excessively high mains voltage may result in an electric shock.

- Only connect the device to a properly installed socket. The mains voltage must match the value indicated on the rating plate.
- In the case of a fault, immediately disconnect the device from the power cable and/or mains.
- Do not connect the device if the device, power cable or a mains plug shows visible signs of damage.
- Damaged power cords and devices must only be repaired by the manufacturer, their customer service or a qualified professional.
- Do not open the housing under any circumstances and never insert any object in the housing.
- Always disconnect the device from the mains before cleaning or servicing it.
- Never touch the mains plug with damp hands.
- Do not immerse the device, power cable or mains plug in water or other liquids.
- Do not bend the power cable and do not pass it over sharp edges.
- Never move the device over the power cable.

Notes on the power cable

- Use only authorised power cables of type H05VV-F or H05RNF.
- They must be approved for outdoor use.

PRODUCT SAFETY WARNINGS

- The length shall not exceed 50 m.
- The power cable wire cross section must be at least 1.5 mm².
- Always completely unroll cable drums before use.
- Check the cable for damage.

WARNING!

Danger for children and persons with impaired physical, sensory or mental capacities (e.g. partially disabled persons, older persons with reduced physical and mental capacities) or lack of experience and knowledge.

Improper handling of the device can lead to severe injuries or damage to the device.

- This lawn mower may be used by persons with impaired physical, sensory or mental capacities or those lacking experience and knowledge if they are supervised or have been instructed in how to safely use the lawn mower and have understood the risks associated with operating it. Children must not play with the lawn mower. Cleaning and user maintenance must not be performed by children.
- Never allow children or other persons, who are not familiar with the user manual, to use the lawn mower. Local provisions can define the minimum age of the user.
- Do not leave the lawn mower unattended while in operation.

CAUTION!

Risk of injury!

Improper handling of the device can cause injuries.

1. The blade is sharp; take care when touching the blade.
2. Do not reach underneath the device or into the discharge chute.
3. Do not operate the device when other persons or animals are around.
4. Do not operate the device if you are impaired (e.g. under the influence of drugs, alcohol, medication or if you are tired).
5. Wear solid shoes, long trousers and hearing protection.
6. Watch out for the power cable as you might trip over it and lose control of the device.
7. Avoid working on wet grass as you might slip and lose control of the device.
8. Do not work on areas with an inclination above 20 % as you might slip and lose control of the device.
9. Always keep the discharge flap closed and keep away from the discharge chute when working without a collecting bag.
10. Wait until the blade stands still before removing any blockage or clogging and carrying out any other work on the device.

Safety symbols

The purpose of safety symbols is to attract your attention to any possible dangers. The safety symbols and their explanations deserve your careful attention and full understanding. The symbol warnings do not, by themselves, eliminate any danger. The instructions and warnings they give are no substitute for proper accident prevention measures.



WARNING: Be sure to read and understand all safety instructions within this operator's manual, including all safety alert symbols such as "**DANGER**", "**WARNING**", and "**CAUTION**" before using this tool. Failure to follow all instructions listed below may result in electric shock, fire and/or serious personal injury.

SAFETY ALERT SYMBOLS: Indicate **DANGER**, **WARNING**, or **CAUTION**. May be used in conjunction with other symbols or pictographs.

Symbol meanings

This page depicts and describes safety symbols that may appear on this product. Read, fully understand and follow all instructions on the machine before attempting to assemble and operate.

PRODUCT SAFETY WARNINGS



Declaration of conformity (see chapter “Declaration of conformity”): Products marked with this symbol meet all the applicable Community regulations of the European Economic Area.



This symbol indicates that the device complies with the protection class II.



General warning sign.
Read the operating manual.



Caution! Discharge of cuttings or stones.
Always keep the discharge flap closed.
Keep other persons and animals out of the working range!



Warning! Rotating blade! Do not reach or step underneath the device.
Disconnect the device from the mains before carrying out maintenance and cleaning work.



Warning! Electric voltage.
Keep the power cable away from the rotating blade! Do not move the device over the power cable.

PRODUCT SAFETY WARNINGS



The symbol shows the maximum sound power level L_{WA} .

IPX4

The device is protected from all sides against water splashes.

UK
CA

Conforms to relevant UK regulatory requirements

TECHNICAL DATA

Model		EM N34A
Rated voltage/frequency		230–240 V~/50 Hz
Rated power		1400 W
Protection class		II
IP rating		IPX4
Max. rpm		3500 min ⁻¹
Cutting width		340 mm
Cutting height		20-70mm, 6 positions
Capacity of grass bag		35 l
Weight		10.6 kg
Measured sound pressure level (L _{pA})		81.8 dB(A) K=3 dB(A)
Measured sound power level (L _{wA})		94.58 dB(A), K=1.72 dB(A)
Guaranteed sound power level		96 dB(A)
Vibrations		0.78 m/s (K = 1.5 m/s ²)

The noise and vibration values were determined in accordance with EN 60335-2-77:2010.

The vibration emission values during actual use of the device may deviate from the declared values. This is independent of the way the device is used.

Users must take all safety precautions to protect themselves. They must consider all influences of the actual application conditions (especially all parts of the work cycle such as running times, idling times and times at which the machine is shut off). The vibration values may deviate from the stated total output depending on the actual use of the device.

Suitable measures include regular maintenance and servicing of the device, keeping your hands warm, taking regular breaks and properly planning the work sequences!

DESCRIPTION OF PRODUCT

Parts description (Fig. A)

1. Handle grip (top)
2. Pull relief (for the power cable)
3. Quick-release lever (handle joint)
4. Bottom part of handle
5. Collecting bag
6. Connecting piece (2x)
7. Carry handle
8. Cutting height lever
9. Motor unit
10. Handle mount
11. Quick-release lever (handle mount)
12. Discharge flap
13. Fill level indicator
14. Cable clamps (2x)
15. Safety switch with power cable
16. Safety bar

Check the delivery parts (Fig. B)

Remove the machine from its packaging carefully and make sure that all of the following parts are present:

- a. Lawnmower with upper handle
- b. Lower handle
- c. Grass bag
- d. Quick-release lever (handle joint)
- e. Connecting piece (2x)
- f. Quick release clamp (fixed in screw) x2
- g. Cable clamps (2x)
- h. Pull relief (for the power cable)
- i. Manual



WARNING: If any parts are damaged or missing, do not operate this tool until these parts have been replaced. Failure to heed this warning could result in serious personal injury.



NOTE: Always recycle the packaging in accordance with local recycling guidelines.

INSTALLATION

Mounting the bottom part of the handle on the lawn mower (Fig. C)

1. Slide the pull relief onto the bottom part of the handle.
2. Slide the connecting pieces onto the bottom part of the handle. The locking washers of the connecting pieces must point inwards.
3. Place the bottom part of the handle on the handle mount. Check whether the serrations of the locking washer engage correctly in the handle mount. The holes of the handle mount, the connecting pieces and the bottom part of the handle must point towards each other.
4. Twist the quick-release levers all the way into the handle mount. Do not use excessive force; it is sufficient to twist in the quick-release lever until you feel a resistance.
5. Flick the quick-release lever. If it is too tight, turn the quick-release lever one turn backwards.

The bottom part of the handle is connected to the lawn mower and does not wobble.

Mounting the handle grip on the bottom part of the handle (Fig. D)

1. Position the pull relief on the crossbar of the handle bottom part.
2. Place the handle grip onto the bottom part of the handle. The connection cable must not lay between the handle parts and should run beneath the handle instead.
3. Align the holes of the handle parts with each other and push the screws from the inside through the handle.
4. Put the washers onto the screw and turn the quick-release levers approximately 5 to 7 turns.
5. Align the handle grip straight on the bottom part of the handle and keep it in position.
6. Align the screw heads. The screw heads are bent and latch into the handle bar.
7. Flick the quick-release levers. If it is too tight, turn the quick-release lever one turn backwards.
8. Check whether the handle grip is aligned and connected to the bottom part of the handle without wobbling.
9. Attach the connection cable with two cable clamps onto the handle frame. (Fig. E)

The connection cable must run beneath the crossbar of the bottom part of the handle.

Attach the grass bag

1. Attach the grass bag to the frame by fixing the plastic hooks onto the side. (Fig. F)
2. Lift the safety flap with one hand and hook in the grass bag. Release the ejector flap to secure the grass bag in position. (Fig. G)

OPERATION

Rules of operation

The following rules must be observed at all times when working on and with the lawn mower.

- Do not adjust the device or rectify faults when it stands still. Make sure that the device cannot start up.
- Only lift the device on the grip and handle. Never reach underneath the device to lift it.
- Let the blade run to a stop before touching the device or the collecting bag again.
- Never reach beneath the discharge flap or into the discharge chute.
- Stop the motor immediately if you notice unusual mowing sounds or vibrations. Check and rectify cause of the fault before resuming mowing.
- Never put a damaged device into operation. Any damage to the blade and the device must be repaired by the manufacturer's customer service or qualified personnel.
- Mow diagonally to inclinations.

Note the following when mowing and mulching

The following instructions help you use the device effectively and safely. Improper handling of the device can cause damage to it.

- The device can be operated with or without collecting bag. You should only operate the device without the collecting bag (mulching) when trimming the lawn just a little shorter (max. 2 cm). Always keep the discharge flap closed when mulching.
- Mow slowly and try not to use the entire cutting width to cut the grass evenly at high rotation speed. A high cutting load reduces the blade's rotation speed.
- Remove any branches, pegs, stones, strings and mounds (molehills) before mowing to safeguard the device.
- Always mow in the direction facing away from the power supply and the power cable.
- Always push the device forward; pulling the device might damage the power cable.

Adjusting the handle position

The handle can be adjusted to a comfortable working height. Adjust the handle to your individual working height before working with the device.

1. Undo the two quick-release levers on the handle mount.
2. Set the handle to the desired height.
3. Check whether the serrations of the locking washer engage correctly in the handle mount.
4. Flick the quick-release levers.

OPERATION

Adjusting the cutting height (Fig. H)

You can set the cutting height between approximately 20 and 70 mm. The cutting height lever can be engaged in 6 positions.

1. Hold the device by the carry handle.
2. Pull the cutting height lever out of its arrester.
3. Slide the cutting height lever to the desired level. The device lifts or lowers.
4. Engage the cutting height lever properly again.

Preparing for operation

Only use an extension cable if the included cable is insufficient for mowing the entire lawn. Avoid using more than one extension cable.

1. Check the device, the collecting bag and the blade before connecting the power supply.
2. Set the desired cutting height before connecting the power supply.
3. Check the handle position and correct it if necessary to work comfortably.
4. Lay out the power cable all along the perimeter of your lawn.
 1. Secure the power cable on the pull relief. **(Fig. I)**
 2. Plug the power cable plug into a properly installed socket.

Turning the motor on and off (Fig. J)

Caution! Blade keeps moving

The motor is activated by means of a safety switch. When you let go of the safety bar, the motor stops. Only turn on the motor on the grass.

1. Place the device on the grass.
2. Press and hold the button of the safety switch.
3. Pull the safety bar towards the handle.

The motor starts.

4. Let go of the safety switch button and keep the safety bar pressed to the handle as long as you operate the motor.

Letting go of the safety bar stops the motor. The blade keeps running. Wait until the blade has stopped before handling the device.

OPERATION

Emptying the collecting bag

The collecting bag has a fill level indicator. The fill level indicator rises when the motor is running and the collecting bag is empty. Once the collecting bag is full, the fill level indicator rests again on the collecting bag. Empty the collecting bag.

NOTE: If cuttings remain on the ground, empty the collecting bag as well.

1. Stop the motor and wait until the blade stands still.
2. Lift the discharge flap until the collecting bag is exposed.
3. Lift the collecting bag off the lawn mower. Slightly lift the collecting bag to release it.
4. Move the discharge flap properly until the discharge chute is covered again. Do not simply let go; the discharge flap may get damaged due to the spring action.
5. Empty the collecting bag completely. Clear cuttings of the fabric as best as possible so that the expelled air can escape properly.
6. Completely lift the discharge flap.
7. Hang the collecting bag onto the hooks above the discharge chute again.
8. Check whether the collecting bag is properly fitted.
9. Move the discharge flap carefully until the collecting bag is covered again.

MAINTENANCE AND STORAGE

Cleaning

Risk of electric shock!

Moisture in the device may cause a short circuit or electric shock.

- Before cleaning, disconnect the power cable from the socket.
- Make sure that no water or other liquid gets inside the housing.
- Never clean the device with running water (e.g. a garden hose).

NOTE: Improper cleaning can damage the device.

- Do not use any harsh cleaning products, brushes with metal or nylon bristles, or sharp or metallic cleaning materials such as knives, hard scrapers or similar. They may damage the surfaces.
- Remove wet cuttings immediately. Residues of wet cuttings on and in the device may harden and cause mould.

Cleaning and inspection after each use

NOTE: Regular cleaning and inspection is necessary to keep the device in perfect state.

1. Stop the motor and wait until the blade stands still.
2. Disconnect the device by unplugging the power cable and remove the power cable from the pull relief.
3. Thoroughly empty the collecting bag (see "Emptying the collecting bag") without reattaching it to the device.
4. Remove cuttings from the device and the collecting bag with a hand brush.
5. Tip the device on its side and remove cuttings from the discharge chute and blade compartment with a hand brush or a brush.
6. Check the blade for damaged spots and wear. Do not operate the device with a damaged or worn blade! If necessary, have the blade sharpened or exchanged in a specialist workshop (for the blade type, see "Technical specifications").
7. Set the device upright again.
8. Check all connections (handle, collecting bag) for tight fit.

The device is ready for storage.

Maintenance

Apart from the measures described in the section "Cleaning and inspection after each use", the device is principally maintenance-free. You do not have to lubricate or readjust any parts.

In addition, check the following once a year:

- Free wheel movement.
- Function and free movement of the cutting height adjuster.
- Function and free movement of the discharge flap.
- Damage to the device, such as broken housing parts or worn collecting bag.

If you detect any defects, contact customer service or a specialist workshop. Do not operate the device with a detected defect.

MAINTENANCE AND STORAGE

Storage

NOTE: Improper storage of the device can result in damage.

- Let the device dry before storing it. Residual moisture and cuttings remaining in the device can lead to mould formation.

Optionally, the handle can be folded in to save space during storage or transport.

Folding in the handle (Fig. K)

1. Release the quick-release levers on the handle mount.
2. Take the serrations of the locking washer out of the handle mount by lifting it slightly and then set down the handle on the device.
3. Release the quick-release levers in the centre of the handle.
4. Carefully fold the handle. Watch out for the connection cable. It must not be pinched between the handle parts.

Storage conditions

- Thoroughly clean the device (see "Cleaning").
- Store the device in a clean, dry, frost-protected place out of the reach of children.
- Store the device in a location away from sunlight and other heat sources.
- Always store device parts and accessories together with the device.
- Store the device and accessories at a temperature between +5°C and +20°C.

Transport instructions

- Always transport the device with the handle folded in (see "Folding in the handle")
- Only lift the device by the carry handle.
- Exclusively transport the device in normal position; prevent tilting while transporting.
- When transporting the device in vehicles, the device must be secured in accordance with the applicable regulations (load securing).

TROUBLESHOOTING

Fault/malfunction	Cause	Remedy
Motor does not start up	The mains plug is not correctly plugged in.	Check that the mains plug is fitted properly.
	The socket does not supply any power/the fuse has blown or the RCCB has tripped.	Check the power cable for damage.
	The button on the safety switch was not pushed.	Let go of the safety bar and push the button on the safety switch before pulling the safety bar again.
	The motor overload protection has triggered, the motor is overheated.	Allow the device to cool down for 15-20 minutes.
Unsteady run The device emits unusual noises Insufficient power	The selected cutting height is too low.	Set the cutting height 2 levels higher.
	Collecting bag is full to the rim or the discharge chute is clogged.	Empty the collecting bag and remove cuttings from the discharge chute.
	Blade is blocked by foreign object.	Check the blade compartment for foreign objects and remove these if present.
	Blade is dull or damaged.	Check the blade and have it sharpened or replaced at a specialist workshop, if necessary.
Cuttings left on ground	Collecting bag is full to the rim or the discharge chute is clogged.	Empty the collecting bag and remove cuttings from the discharge chute.
	Grass is too wet.	Wait for the grass to dry.

DECLARATION OF CONFORMITY

To the provisions of Council Directives

We
MEROTEC GmbH
Otto-Brenner-Str. 8
47877 Willich
Germany

Declare that the product:
Machine Description: Electric lawnmower
EM N34A/ SLM 34L
Function: Cutting grass

Complies with the essential health and safety requirements of the following directives:

Machinery Directive 2006/42/EC
Electromagnetic Compatibility Directive 2014/30/EU
EC Directive 2011/65/EU and its amendment Directive (EU) 2015/863 (RoHS)
Noise Emission in the Environment by Equipment for Use Outdoors Directive 2000/14/EC amended by 2005/88/EC
We additionally confirm the following in accordance with the 2000/14/EC amended by 2005/88/EC emissions guideline,
Conformity Assessment Procedure as Per Annex III,
TÜV Rheinland LGA Products GmbH - Tillystraße 2 -90431 Nürnberg
Notified under No. 0197
Measured Sound Power Level: $L_{WA} = 94.58 \text{ dB(A)}$, $K = 1.72 \text{ dB(A)}$
Declared Guaranteed Sound Power Level: 96 dB (A)

Standards and technical specification referred to :

EN 60335-2-77:2010
EN 60335-1: 2012+A11+A13+A14+A2+A15
EN 62233:2008
EN IEC 55014-1:2021
EN IEC 55014-2:2021
EN IEC 61000-3-2:2019+A1
EN 61000-3-3:2013+A1+A2
EN 50581:2012

Authorized Signatory
Date: 21.01.2023

Signature: 

Place: Willich

Name: Roland Menken
General Manager

MEROTEC GmbH
Otto-Brenner-Str. 8, 47877 Willich, Germany



DECLARATION OF CONFORMITY

To the provisions of Council Directives

We

SUMEC UK

Unit A&B Escrick Business Park Escrick, York YO19 6 FD

United Kingdom

Declare that the product:

Machine Description: Electric lawnmower

EM N34A/ SLM 34L

Function: Cutting grass

Complies with the essential health and safety requirements of the following directives:

Supply of Machinery (Safety) Regulations 2008

Electromagnetic Compatibility Regulations 2016

The Restriction of the Use of Certain Hazardous Substances in Electrical and Electronic Equipment Regulations 2012

Noise Emission in the Environment by Equipment for use Outdoors Regulations 2001 Measured Sound

Measured Sound Power Level: $L_{wA} = 94.58 \text{ dB(A)}$, $K = 1.72 \text{ dB(A)}$

Declared Guaranteed Sound Power Level: 96 dB (A)

Standards and technical specification referred to :

EN 60335-2-77:2010

EN 60335-1: 2012+A11+A13+A14+A2+A15

EN 62233:2008

EN IEC 55014-1:2021

EN IEC 55014-2:2021

EN IEC 61000-3-2:2019+A1

EN 61000-3-3:2013+A1+A2

EN 50581:2012

Authorized Signatory

Date: 21.01.2023

Signature: M. Hall

Place: York

Name: Mariana Hall

General Manager

SUMEC UK

Unit A&B Escrick Business Park Escrick York YO19 6 FD

United Kingdom

