

Original User's Instructions

150cc Self Propelled Petrol Lawn Mower

SKU: 15564

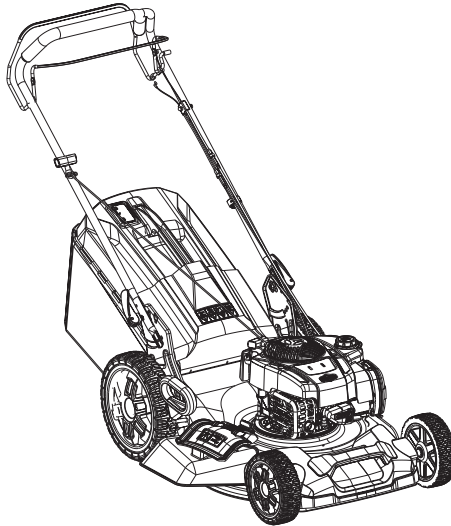

WHAT'S IN THE BOX

Grass collection bag x 1

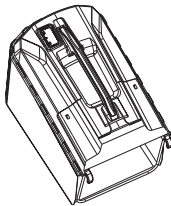

Cable clip x 1

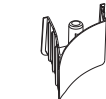

Mulching plug x 1



Spark plug
wrench x 1

Main mower deck x 1

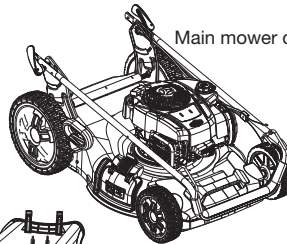

Side discharge chute x 1

If you do not have all these items, please contact:

www.coreservice.co.uk

Hotline: +44 01904 947568

Email support@coreservice.co.uk

PLEASE KEEP THESE INSTRUCTIONS FOR FURTHER REFERENCE

SPECIFICATION

Technical Data	
Property	Value
Engine type	Single cylinder 4-stroke
Engine displacement	150cm ³
Engine power	2.2kW/ 2900/min
Max. engine speed	2900/min
Cutting width	53cm
Grass bag capacity	62L
Ignition	T.C.I
Fuel tank capacity	0.8L
Oil tank capacity	0.47L
Measured sound power level	92.6 dB(A)
Guaranteed sound power level	98 dB(A) K=3dB(A)
Vibration	3.54m/s ² k=1.5m/s ²
Spark type	XC92YC
Net weight	35kg

EXPLANATIONS AND SYMBOLS, CAUTIONS AND WARNINGS



Please read all of the safety and operating instructions carefully before using this machine. Read the instruction manual before operating.



Keep bystanders away - especially children and pets.



Beware of sharp blades - remove the spark plug lead before maintenance.



No naked flames.



Appropriate ear, eye, and head protection (PPE) must be worn.



Hot surfaces will burn the hands!



Warning! The lawn mower's exhaust gas contains toxic substances. Do not run the engine in closed or poorly-ventilated areas.



STOP

The blade continues to rotate for a period after the machine is switched off. Do not touch the blade until all the machine components have stopped completely.



Sound level data (98 dB), in accordance with Directive 2000/14/EC.



The product complies with the applicable European directives, and an evaluation method of conformity for these directives was done.



Add engine oil.
Only refuel with unleaded petrol.



UK Conformity Assessed

HEALTH AND SAFETY



WARNING! Read all safety warnings and instructions.

Failure to follow the warnings and instructions may result in electric shock, fire and/or serious injury.



WARNING! Read all safety warnings and instructions designated by the symbol.

Save all warnings and instructions for future reference.

- Always ensure anyone intending to operate this machine is fully conversant with the contents of this instruction manual prior to assembling, maintaining or operating the machine.
- Perform assembly operations as described in this manual. Failure to observe this warning may lead to serious injury, death, or damage to the machine.
- Always take care when removing the packaging, to prevent damage to you or to the machine.

IMPORTANT! Before assembling the machine, check all the parts indicated in the manual are in the box. Inspect all the parts for signs of damage. Do not assemble the machine if you observe any damaged components.

NOTE: This lawn mower complies with the Noise Emission Directive 2000/14/EC.

General safety

- Keep this operating and maintenance manual in a safe place for reference at a later date.
- Read the instructions carefully. Be familiar with the controls and the proper use of the equipment.

- Never allow children or people unfamiliar with these instructions to use the lawn mower. Local regulations can restrict the age of the operator.
- Never mow while people, especially children or pets, are nearby. Keep in mind that the operator or user is responsible for accidents or hazards occurring to other people or their property.
- This appliance is not intended for use by people (including children) with reduced physical, sensory or mental capabilities, or lack of experience and knowledge, unless they have been given supervision or instruction concerning the use of the appliance by a person responsible for their safety.
- Never touch a rotating blade.

Personal safety

- While mowing, always wear substantial footwear and long trousers. Do not operate the equipment when barefoot or wearing open-toed sandals.
- Thoroughly inspect the area where the equipment is to be used and remove all objects which can be thrown by the machine.
- Petrol is highly flammable; store fuel in containers specifically designed for this purpose.
 - a) Refuel outdoors only and do not smoke while refuelling.
 - b) Add fuel before starting the engine. Never remove the cap of the fuel tank or add petrol while the engine is running, or when the engine is hot.
 - c) If petrol is spilled, do not attempt to start the engine but move the machine away from the area of spillage, and avoid creating any source of ignition until petrol vapours have dissipated.
 - d) Replace all fuel tank and container caps securely.

- Replace faulty silencers.
- Prior to use, visually inspect to see that the blade, blade bolts and cutter assembly are not worn or damaged. Replace worn or damaged blades and bolts in sets, to preserve balance.

Operation safety

- Do not operate the engine in a confined space where dangerous carbon monoxide fumes can collect.
- Mow only in daylight or in good artificial light.
- Avoid operating the equipment on wet grass, where feasible.
- Always be sure of your footing on slopes.
- Walk, never run.
- Mow across the face of a slope, never up and down.
- Exercise extreme caution when changing direction on slopes.
- Do not mow excessively steep slopes.
- Use extreme caution when reversing or pulling the lawn mower towards you.
- Stop the blade if the lawn mower has to be tilted for transportation when crossing surfaces other than grass, and when transporting the lawn mower to and from the area to be mowed.
- Never operate the lawn mower with defective guards, or without safety devices, for example deflectors and/or grass catchers, in place.
- Do not change the engine governor settings or over speed the engine.
- Start the engine carefully according to the instructions and with feet well away from the blade.
- Do not tilt the lawn mower when starting the engine.
- Do not start the engine without the grass collector in place.
- Do not put hands or feet near or under rotating parts. Keep clear

of the discharge opening at all times.

- Never pick up or carry a lawn mower while the engine is running.
- Stop the engine and disconnect the spark plug cable, making sure that all moving parts have come to a complete stop:
 - a) Before clearing blockages or unclogging the chute.
 - b) Before checking, cleaning or working on the lawn mower.
 - c) After striking a foreign object, inspect the lawn mower for damage and make repairs before restarting and operating the lawn mower.
 - d) If the lawn mower starts to vibrate abnormally, check immediately.
- Stop the engine and disconnect the spark plug wire, and make sure that all moving parts have come to a complete stop before refuelling.

Maintenance and storage

- Keep all nuts, bolts and screws tight, to be sure the equipment is in safe working condition.
- Never store the equipment with petrol in the tank inside a building where fumes can reach an open flame or spark.
- Allow the engine to cool before storing in any enclosure.
- To reduce the fire hazard, keep the engine, silencer, and petrol storage area free of grass, leaves, or excessive grease.
- Check the grass collector frequently for wear or deterioration.
- For safety, always replace worn or damaged parts.
- If the fuel tank has to be drained, this should be done outdoors.

COMPONENT LIST

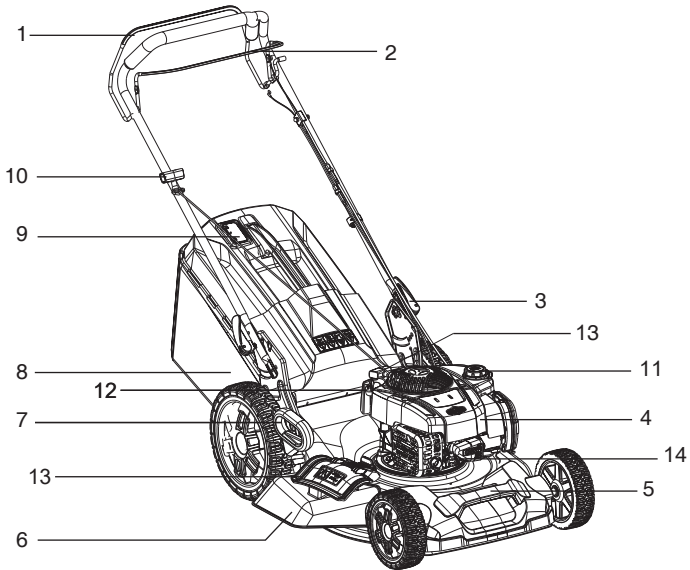

1. Propulsion lever
2. Start stop lever
3. Quick release knob
4. B&S engine
5. Bumper handle
6. Side discharge chute
7. Height adjustment handle
8. Grass box
9. Full grass indicator
10. Starter handle
11. Fuel cap
12. Oil cap
13. Side discharge cover
14. Spark plug

Not all the accessories illustrated or described are included in standard delivery.

ASSEMBLY AND USE

INTENDED USE



WARNING!

Always take care when removing the packaging, to prevent damage to you or to the lawn mower.

This item requires a two-person lift to remove it from the packaging. Make sure that you have sufficient space to put the lawn mower down. Keep your feet apart so that you have a stable position; bend at the knees and keep your back straight.

Always recycle the packaging in accordance with local recycling schemes.

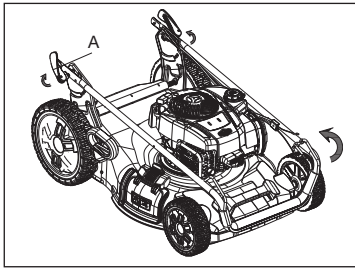

Attaching the handle

1. Rotate the quick clamp (A) 180°, fully open to disengage the quick clamp.
2. Lift the handle to the required height. NOTE: There are 3 hoses in the frame support (B). Choose the same position on both sides to fix the quick clamp.
3. Rotate the quick clamp 180° to fully engage the quick clamp.

Note: If the fixation for the quick clamp is not tight enough, use a wrench to tighten the M8 nut (C).

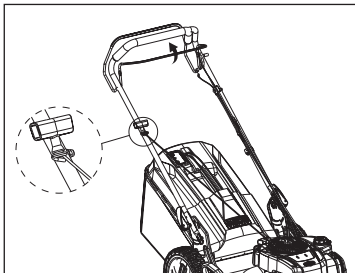
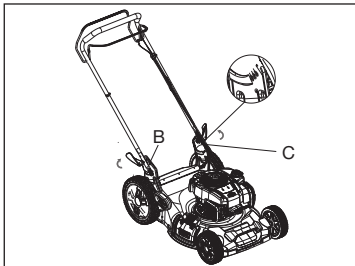

Hook the cord

Pull the on/off lever and gently pull the rope. Hook it around the guide rope.

Grass bag assembly



IMPORTANT!

Make sure the grass collection bag is in place before starting the engine.

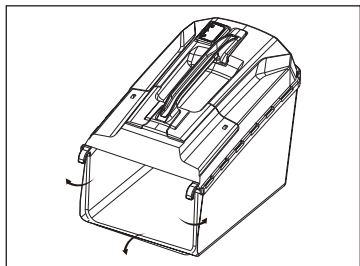

1. Attach the grass bag to the frame by fixing all the plastic hooks.

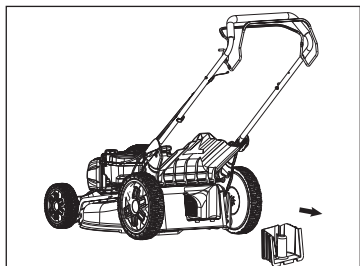

2. If using the collection function, raise the safety flap and take out the mulching plug, and hook the collection bag onto the mower. Ensure the side discharge chute is not fitted when collecting the grass in the bag. Release the safety flap.

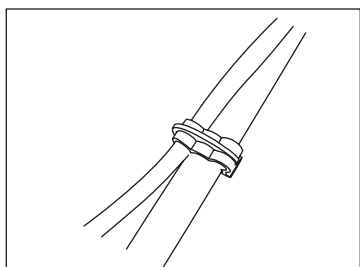
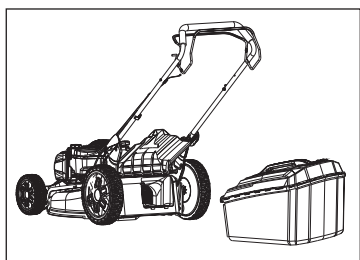

Attach the cable clips

Ensure that the cable clips supplied are used to fix the cable to the handle.

STOP!

Do not start the engine before putting 500ml of SAE 30 oil into the engine.

Failure to do so will result in irreparable damage to the engine and invalidate your warranty.

Preparing to Operate The Lawn Mower Filling with engine oil



IMPORTANT!

The following procedures and adjustments must be performed before the engine is started. Do not attempt to make any of these adjustments while the engine is running.

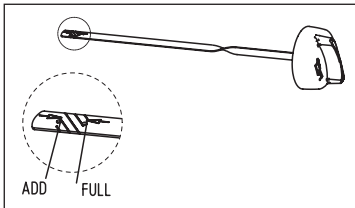
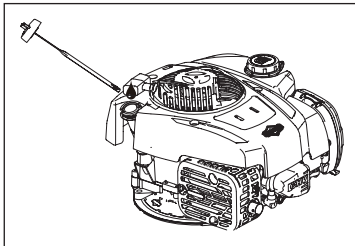

This engine is shipped without oil or petrol; any oil residue is from testing prior to shipping.

The engine must be filled with the correct grade of oil and petrol before starting the engine.

Running the engine with a low oil level will cause irreparable engine damage.

Always use high-quality detergent oil classified SAE 30 oil (or equivalent, e.g. 5W 30, often termed as 4-stroke lawn mower oil). Only use additives recommended by the engine manufacturer. To prolong the life of your engine, it is important that the oil is changed after the first 5 hours of use.

Using non-detergent oil can shorten the engine's service life, and using 2-stroke oil will damage the engine.

Check the engine oil level with the engine stopped and the mower on a flat surface.

1. Remove the oil filler dipstick and wipe it with a clean cloth.
2. Insert the dipstick into the oil filler neck, and screw it in.
3. Then remove the dipstick and check the oil level. The oil level must be between the min. and max. marks on the dipstick. If near the lower level, fill to the upper level with the

recommended oil (SAE 30 or equivalent). Do not overfill. Wipe away any spilled oil.

4. Before using for the first time, add 0.5 litres of oil (SAE 30).

Filling with engine fuel



WARNING!

Refuel in a well-ventilated area with the engine stopped. Do not smoke or allow flames or sparks in the area where the engine is refueled or where petrol is stored. Avoid repeated or prolonged contact with skin or inhalation of vapour.

CAUTION!

Petrol is highly flammable and extreme caution must be taken when handling or working with it. Keep out of the reach of children.

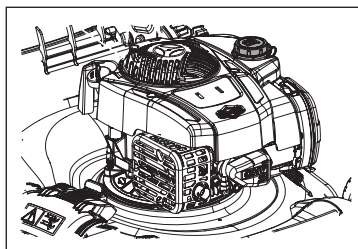

1. Clean the area around the petrol filler cap before removing the cap. Check the fuel level.

2. Refill the tank if the fuel level is low.

3. Always use clean, fresh unleaded petrol and purchase fuel in quantities that can be used within 30 days.

4. Never mix oil with petrol.

5. To allow for expansion, refuel carefully and avoid overfilling or spillage. There should be no fuel in the filler neck.

6. Clean up any overflow or splashes of petrol before starting the engine.

7. Tighten the filler cap after filling, finger tight only.

Note: The 53cm SP lawn mower has a maximum fuel capacity of 800ml.

Operation

Setting the cutting height



WARNING!

The blade can cause serious injury. Before adjusting the mower height, stop the engine and wait for the mower blade to come to a complete stop.

1. Pull the lever towards the wheel, then move it forward or backward to adjust the cutting height.

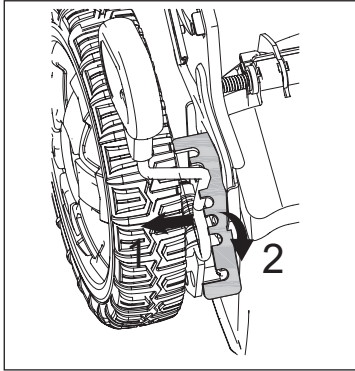

2. Move it to any one of the 7 positions for the desired cutting height.
3. Return the lever into the securing plate.

Position	Approx. cutting height (mm)
1	25mm
2	30mm
3	36mm
4	42mm
5	53mm
6	64mm
7	75mm

Note: Never use the lowest cutting height for the first cut of the season or in drought conditions. Only about one third of the grass height should be cut at this time.

Starting the engine



WARNING!

Do not operate the machine in enclosed or poorly-ventilated areas, as the exhaust gas contains toxic substances. Keep hands, feet, hair and clothing away from all the moving parts of the machine. The exhaust and other parts of the machine will become hot during use. Make sure that the blade is securely fastened before starting the engine.

Step 1 - Starting procedure: quick guide



To start the engine, make sure that the spark plug cap is located on the plug and the machine is filled with sufficient oil and petrol.

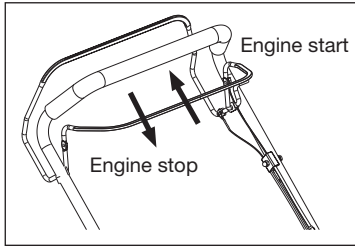

Step 2 - Start/stop bar activation

Pull the start/stop bar towards you.

Step 3 - Pull the cord handle

With the right hand, slowly but firmly pull the starter handle and rope from the pull cord guide until you feel resistance, then pull briskly. If the engine fails to start after three pulls, repeat the start process. When the engine starts, gently return the starter rope to the pull cord guide.

To stop, release the stop/start bar

Failure to start

If the engine won't start after you have operated the starter several times, the engine may be flooded with excess fuel. Use the following procedure to clean and start a flooded engine:

- A. Release the stop/start bar.
- B. Remove the spark plug, dry it, and then reinstall it. Install the spark plug carefully by hand, to avoid cross-threading. After the plug is seated, tighten it 1/8 to 1/4 turns with the socket spanner to compress the washer.
- C. Pull the stop/start bar towards the upper handle.
- D. Operate the starter, as described in steps 2-3.

Mowing with the grass collection bag



WARNING!

Always observe the strictest safety procedures when using the lawn mower.

Start the engine and allow it to run. See 'Step 2 - Starting the engine'.

Keep a firm grip on the upper handle and stop/start bar and pull the self propelled lever towards you to let mower forward. Walk along with it, never run with the mower. Be very careful when mowing uneven or rough ground. Maintain a stable footing.

Mow across slopes, never up and down. Be careful when changing the direction of the mower on a slope. Do not use the mower on a steep slope of more than 15°.

Note: The best result will be achieved if the grass is dry. Wet grass will tend to clog the blade and the grass collection system.

Grass grows at different rates at different times of the year. Never use the lowest cutting height for the first cut of the season or in drought conditions. Only about one third of the grass height should be cut at this time.

If the lawn mower will not collect the cuttings efficiently, the grass discharge chute may be blocked, the grass bag may be full, or the underside of the mower deck may be clogged.

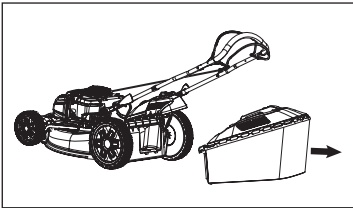

Emptying the grass collection bag

Raise the discharge flap with one hand and remove the grass bag using its handle with your other hand. To maintain safety, the discharge flap will close back to cover the mulching plug when you release the flap.

Empty the grass debris in to the grass collection bag and refit the bag. If any grass residues are caught in the discharge chute, clean it using a brush.

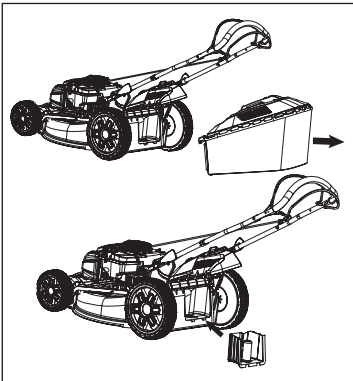

Mowing with the mulcher

When mulching, remove the collection grass bag, and put the plastic mulching plug into the rear discharge chute. Then release the flap, it will close back to cover the mulching plug.

Make sure that the side discharge chute is not fixed on the deck.

Note: To ensure that the cut grass can be mulched efficiently, do not cut high or wet grass.

Mowing with the side discharge

When using the side discharge to throw grass, you first need to remove the grass collection bag and insert the mulching plug. Follow the steps below to assemble the side discharge chute:

1. Push the lock button with one hand;
2. Raise the side discharge cover with another hand;
3. Hold the side discharge cover open, hook the side discharge chute onto the mower then release the discharge cover back.

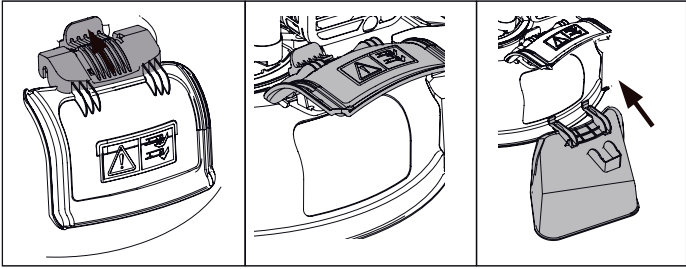

CARE AND CLEANING

Maintenance and Storage

Storing the lawn mower for short periods

After mowing, please follow the actions below prior to placing the lawn mower in storage:

- Allow the engine to cool down fully.
- Ensure the grass collection bag is empty.
- Clean all debris from under the mower deck.
- Store the lawn mower on a flat and level surface, with all 4 wheels on the ground.
- Store in a dry, safe place, which is not accessible to children or people who are not familiar with operating the machine.

Storing the lawn mower for extended periods



CAUTION! Do not empty the petrol tank in enclosed areas, near fire or when smoking. Petrol fumes can cause explosions and fire. Always carry the product on its gripping surfaces.

If the lawn mower is to be placed into storage at the end of the season, or if the mower is not to be used for a longer period than 6 weeks, storage maintenance must be performed, as follows:

- Temperature fluctuations cause condensation, which contaminates fuel and causes starting problems. Simply emptying the machine of fuel will prevent this.
- Empty the petrol tank with a petrol suction pump, if available, or use the tipping method.
- Start the engine and let it run until any remaining petrol has been used up.
- Change the oil at the end of every season. To do so, remove the used engine oil from a warm engine and refill with fresh oil.
- Remove the spark plug from the cylinder head. Fill the cylinder with approx. 20ml of oil from an oil can. Slowly pull back the starter handle, which will bathe the cylinder wall with oil, and screw the spark plug back in.
- Clean the cooling fins of the cylinder and the housing.
- Be sure to clean the entire machine to protect the paint.
- Store the machine in a well-ventilated place.

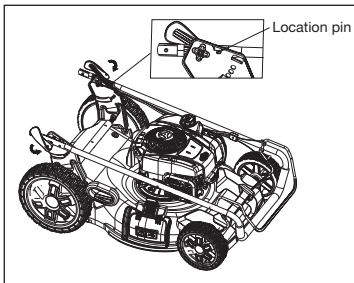

MOW & STOW

This mower can be stored vertically to save space:

1. Fold the handle, and fix the quick clamp tightly.
2. Set the cutting height to the top 3 working heights.

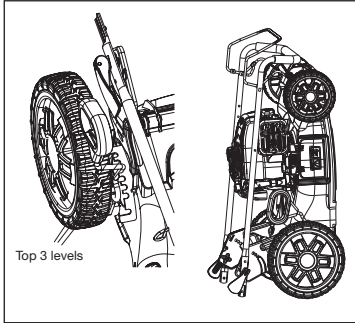

Important! Always drain the petrol before vertical storage.

Note: Alternatively, adding Briggs & Stratton FUEL FIT to the fuel will prevent contaminated fuel. Not all additives on the market do this. FUEL FIT can be ordered via www.gardenservicecentre.co.uk.

Preparing to re-use the mower

Check the oil level before starting the engine to ensure there is sufficient oil, see page 14.

Check the spark plug is inserted correctly, see page 24.

Fill engine with fresh unleaded fuel, see page 14.

Follow starting procedure, see page 15.

Maintenance schedule



WARNING!

Before you tip the lawn mower onto its side, completely empty the fuel tank using a petrol suction pump.

Never turn the mower upside down.

Before commencing any maintenance, always disconnect the spark plug.

Performing routine maintenance correctly on your lawn mower will ensure you get years of trouble-free use.

Please keep this manual safe for future reference.

It is recommended that the following maintenance schedule is adhered to. This will ensure the lawn mower operates correctly and is safe to use.

	After every use	After 12 hours use	After 24 hours use	After 36 hours use
Cleaning	clean	clean	clean	clean
Air filter		clean	clean	replace
Spark plug		check	check	replace
Engine oil	check	check	check	check
Cutting blade	check	check	check	replace

NOTE: The engine oil should be changed after the first 5 hours.

Cleaning

- To ensure long life and good performance of the machine, it's important to keep the machine clean and well lubricated. Make sure the chute is clean and under the deck is cleared from wet debris. (See also short term storage).
- Do not allow grass cuttings and other debris to become dry and hard on any of the mower surfaces, as this will directly affect the cutting and grass collection performance.

Make sure that the underside of the lawn mower deck is clean and clear.

- Never clean the lawn mower with a water jet or high-pressure cleaner. The engine must remain dry. Do not use aggressive cleaning agents or solvents, such as cold degreasers or petroleum ether.

Cleaning or replacing the air filter

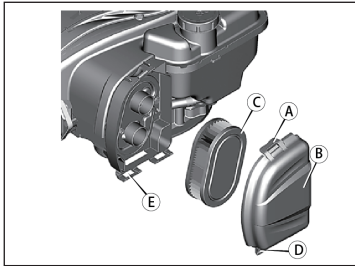

WARNING!

Never run the engine without the air filter element installed:

1. Loosen the fastener (A) that holds the cover (B).
2. Open the cover and remove the filter (C).
3. To loosen debris, gently tap the filter on a hard surface. If the filter is excessively dirty, replace with a new filter.
4. Install the air filter.
5. Install the cover tabs (D) into the slots (E).
6. Close the cover and secure with the fastener (A).

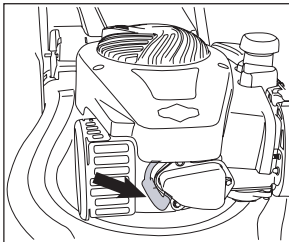

Cleaning or replacing the spark plug

1. Once the engine has cooled, pull off the spark plug boot with a twist. Remove the spark plug using the socket spanner supplied.
2. Clean the plug with a wire brush.
3. Using a feeler gauge, set the gap to 0.51mm.
4. Install the spark plug carefully by hand to avoid cross-threading.
5. After the spark plug is seated, tighten with the spanner to compress the washer.

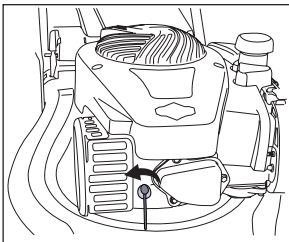

0.43-0.51mm

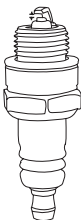

Adding the oil

Refill with SAE 30 oil or equivalent, i.e. SAE 5W/30, SAE 10W/30). When the dipstick is rested on the filler pipe, the oil level must be between the min. and max. marks on the dipstick.

See 'Filling with engine oil'. Do not overfill.

Start the engine and allow it to run briefly.

Stop the engine, wait one minute and check the oil level. Top up if necessary.

Replacing the cutting blade



WARNING! USE GLOVES.

Before you remove the grass collection bag, stop the engine and wait until the blade stops completely.

You will need garden gloves (not provided) and a spanner wrench to remove the blade.

Always handle the blade with care; sharp edges could cause injury.

NEVER hold the blade directly by hand.

Renew your metal blade after 36 hours of mowing or after 2 years, whichever is sooner, regardless of condition.

Regularly check your blade. If the cut of your grass is poor, the blade might be blunt.

Damaged blades not only result in a bad cut, they cause excessive vibration and uneconomical running of the engine. If the blade has worn excessively and become pitted and blunt, it should be replaced or sharpened.

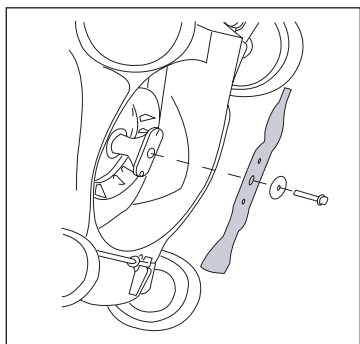

Note: The blade carrier is designed to break under heavy blade impact to protect the machine. If this happens, also replace the blade carrier. This can be purchased from www.gardenservicecentre.co.uk.

To replace the blade, hold the blade and unscrew the blade bolt counterclockwise using a spanner wrench. Remove the washer and the blade.

Inspect the blade adaptor for any signs of damage.

Fit a new blade, locate the blade on the two studs on the blade flange and then replace the washer and bolts.

Check the washer is still slightly domed to keep the pressure on the bolt and stop it unwinding, keeping the blade firmly secure. Then replace the washer (right way around!) and bolts.

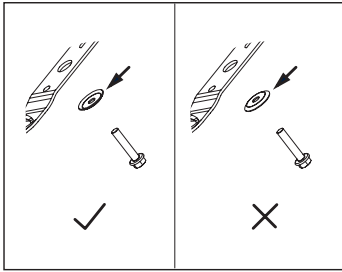

Make sure the blade is correctly located, and then firmly tighten the bolt. Do not over tighten. The up turn of the blade must project into the motor compartment.

Note: If you are unsure about performing this operation, call our helpline or go to an authorised dealer to change the blade for you.

List of consumable parts:

XC92YC	Spark plug	974213	Blade
974225	Blade bolt	974008	Mulching plug
1812903	Collection grass bag	916203	Blade washer
1813904	Quick clamp		

TROUBLE SHOOTING



WARNING!

Always switch off the engine and pull the ignition cable before starting any inspection or adjustment work.

If after making an adjustment or repair to the engine you let it run for a few minutes, remember that the exhaust and other parts will get hot.

The following table provides solutions to common problems encountered with the lawn mower:

Fault	Possible Cause	Solution
Loud while running, machine vibrates heavily	<ul style="list-style-type: none"> - Screws are loose - Blade fasteners are loose - Blade is unbalanced 	<ul style="list-style-type: none"> - Check screws - Check blade fasteners - Replace blade
Engine does not start	<ul style="list-style-type: none"> - Start/stop bar not pressed - Spark plug is defective - Fuel tank is empty - Engine may be flooded 	<ul style="list-style-type: none"> - Press start/stop bar - Replace spark plug - Refill with fuel - Remove plug and dry, see page 24
Engine runs unsteadily	<ul style="list-style-type: none"> - Air filter is soiled - Spark plug is soiled 	<ul style="list-style-type: none"> - Clean the air filter - Clean the spark plug
Uneven mowing results	<ul style="list-style-type: none"> - Blade is blunt - Cutting height is too low 	<ul style="list-style-type: none"> - Sharpen the blade - Set correct height
Unsatisfactory grass collection	<ul style="list-style-type: none"> - Cutting height is too low - Blade is worn - Grass bag is clogged 	<ul style="list-style-type: none"> - Set correct height - Replace the blade - Empty the grass bag

DECLARATION OF CONFORMITY / PERFORMANCE



Product Code: 15564/ XSZ53D-SD

**Product Description Hawksmoor: 150cc 53cm Briggs & Stratton Self Propelled Petrol
Lawnmower**

1. Toolstation Limited, Express Park, Bristol Road, Bridgwater, Somerset TA6 4RN

This declaration of conformity is issued under the sole responsibility of Toolstation

2. Object of the declaration

The object of the declaration described above is in conformity with the relevant Community harmonization legislation:

Supply of Machinery (Safety) Regulations 2008

2006/42/EC

Electromagnetic Compatibility Regulations 2016

2014/30/EU

The Restriction of the Use of Certain Hazardous Substances in Electrical and Electronic Equipment Regulations 2012

2011/65/EU&(EU)2015/863

Noise Emission in the Environment by Equipment for use Outdoors Regulations 2001

2000/14/EC amended by 2005/88/EC:

- Conformity Assessment Procedure as per Annex VI
- Measured Sound Power Level 97 dB(A)
- Declared Guaranteed Sound Power Level 98 dB(A)

3. References to the relevant standards used (or references to the specifications in relation to which conformity is declared:

BS EN ISO 5395-1, BS EN ISO 5395-2, BS EN ISO 14982, BS EN ISO 3744;

4. Additional information:

Signed for and on behalf of Toolstation Limited

ENVIRONMENTAL INFORMATION

Old products are potentially recyclable and do not, therefore, belong in your household rubbish. You are requested to assist us and our contribution to saving resources and protecting the environment by handing in this product at an equipped collection centre (if there is one available).

Petrol, oil, used oil, a mixture of oil and petrol and objects soiled with oil e. g. cleaning cloths do not belong in the household rubbish. Dispose of oil-contaminated items in accordance with the local guidelines and hand them in at recycling centres.

The product comes in a package that protects it against damage during shipping. Keep the package until you are sure that all parts have been delivered and the product is function properly. Recycle the package afterwards.

GUARANTEE

Toolstation products deliver reliable service for normal, household use in domestic settings. All Toolstation products are individually tested before leaving the factory.

If you are a consumer and you experience a problem with your Toolstation product, which is found to be defective due to faulty materials or workmanship within the Guarantee Period, this Toolstation Guarantee will cover repair or - at the discretion of Toolstation - replacement with a functionally equivalent Toolstation product.

Your product is under guarantee for 2 year from the date of purchase or the date of delivery of the product, if later.

The guarantee is subject to the following provisions:

- The guarantee does not cover accidental damage, misuse, cabinet parts, knobs, or consumable items.
- The product must be correctly installed and operated in accordance with the instructions contained in this manual.
- It must be used solely for domestic purpose.
- The guarantee will be rendered invalid if the product is re-sold or has been damaged by inexpert repair.
- Specifications are subject to change without notice.
- The manufacturer disclaims any liability for the incidental or consequential damages.
- The guarantee is in addition to, and does not diminish your statutory or legal rights.

CUSTOMER SUPPORT

www.coreservice.co.uk

Call us +44 01904 947568

Email: support@coreservice.co.uk

Made in China