

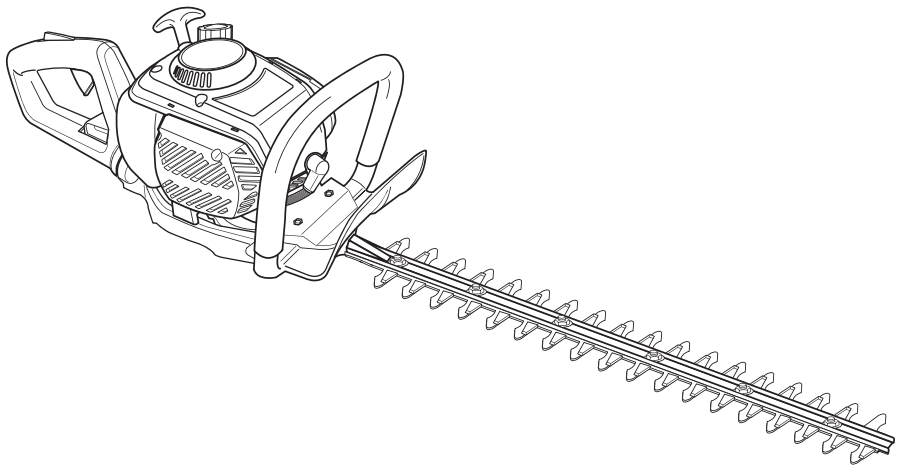

Original User's Instructions

26cc Petrol Hedge Trimmer

SKU: 90364



READ BEFORE USE

PLEASE KEEP THESE INSTRUCTIONS FOR FURTHER REFERENCE

CONTENT

• WHAT'S IN THE BOX -----	3
• SPECIFICATIONS -----	4
• EXPLANATIONS AND SYMBOLS, CAUTIONS AND WARNINGS -----	5
• IMPORTANT SAFETY WARNINGS -----	7
• PRODUCT DESCRIPTION AND IDENTIFICATIONS -----	15
• ASSEMBLY AND OPERATING INSTRUCTIONS -----	16
• CARE AND CLEANING -----	28
• TROUBLE SHOOTING -----	35
• DECLARATION OF CONFORMITY / PERFORMANCE -----	37
• ENVIRONMENTAL INFORMATION -----	38
• GUARANTEE -----	39
• CUSTOMER SUPPORT -----	39

WHAT'S IN THE BOX

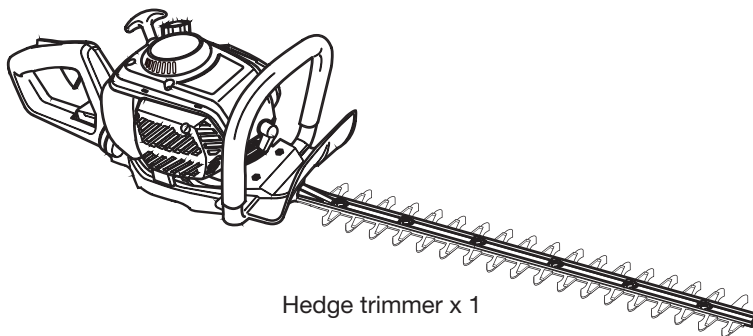

Hedge trimmer x 1

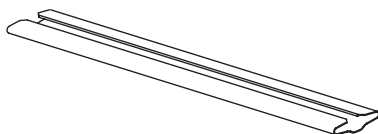

Blade cover x 1



Socket wrench/cross head
screw-driver x 1

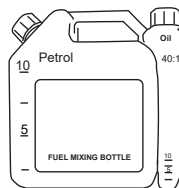

Mix bottle x 1

If you do not have all these items, please contact:

www.coreservice.co.uk

Hotline: +44 01904 947568

Email support@coreservice.co.uk

SPECIFICATION

Technical Data	
Property	Value
Engine type	Single-cylinder, 2-stroke
Displacement (cc)	26cm ³
Max. power/engine speed	0.75 kW/10000 min ⁻¹
Cutting capacity	27mm
Tank capacity	460ml
Idle speed	3000min ⁻¹
Clutch speed	5230min ⁻¹
Ignition	C.D.I
Cutting length	550mm
Fuel ratio (petrol: 2 cycle motor oil)	40:1
Net weight	5.3kg
Sound pressure level L _{PA} (dB)	94.6dB(A) K=3dB(A)
Sound power level L _{WA} (dB)	105.6dB(A) K=2.04dB(A)
Vibration (m/s ²)	Front handle 3.378m/s ² Rear handle 7.152m/s ² ; K=1.5 m/s ²
Spark plug type	Torch L8RTC

The declared vibration value has been measured in accordance with a standard test method and may be used for comparing one tool with another. The declared vibration value may also be used in a preliminary assessment of exposure.

EXPLANATIONS AND SYMBOLS, CAUTIONS AND WARNINGS



IMPORTANT!

Please read all of the safety and operating instructions carefully before using this tool. Please pay particular attention to all sections of this user guide that carry warning symbols and notices.



WARNING!

This is a warning symbol. This symbol is used throughout the user guide whenever there is a risk of personal injury. Ensure that these warnings are read and understood at all times.



The product complies with the applicable European directives, and an evaluation method of conformity for these directives was done.



The exhaust gas is poisonous and asphyxiating. If inhaled, it may even be lethal. Do not operate the engine in closed or poorly ventilated places.



Petrol and petrol vapours are extremely flammable.



To prevent burns, do not touch.



Keep fingers away from moving cutting device!



Wear robust footwear when using the device.



Wear respiratory protection.



Wear hearing protection and eye protection (PPE) when using the device.



Wear protective gloves when using the device.



Guaranteed sound power level.



UK conformity assessed



The direction to close the choke
Position: TOP COVER



The direction to open the choke
Position: TOP COVER



Press the prime bulb



The recommended mixing ratio for petrol:oil is 40:1.

IMPORTANT SAFETY WARNINGS

General Safety Warnings

Safety warnings



WARNING! Read all safety warnings and instructions.



WARNING! Read all safety warnings and instructions designated by the symbol. Save all warnings and instructions for future reference.

- Always ensure anyone intending to operate this machine is fully conversant with the contents of this instruction manual prior to assembling, maintaining or operating the machine.
- Perform assembly operations as described in this manual. Failure to observe this warning may lead to serious injury, death, or damage to the machine.
- Always take care when removing the packaging, to prevent damage to you or to the machine.

IMPORTANT! Before assembling the machine, check all the parts indicated in the manual are in the box. Inspect all the parts for signs of damage. Do not assemble the machine if you observe any damaged components.

General safety

- Keep this operating and maintenance manual in a safe place for reference at a later date.
- Read the instructions carefully. Be familiar with the controls and the proper use of the equipment.

- Never allow children or people unfamiliar with these instructions to use the hedge trimmer. Local regulations can restrict the age of the operator.
- Never trim while people, especially children or pets, are nearby. Keep in mind that the operator or user is responsible for accidents or hazards occurring to other people or their property.
- This appliance is not intended for use by persons (including children) with reduced physical, sensory or mental capabilities, or lack of experience and knowledge, unless they have been given supervision or instruction concerning the use of the appliance by a person responsible for their safety.
- Do not touch the blade.

Personal safety

- Never start or run the engine in a closed or poorly ventilated area; breathing exhaust fumes can kill.
- Clear the work area before each use. Remove all objects, such as rocks, broken glass, nails, wire, or other such debris, which can be thrown or become entangled in the cutting line or blade.
- Wear Personal Protective Equipment (PPE), such as safety glasses or goggles, when operating this unit.
- Wear heavy, long trousers, boots, and gloves. Do not wear loose fitting clothing, shorts, or go barefoot. Do not wear jewellery of any kind.

Operational safety

- Be careful about the environmental conditions you work under. When starting the motor, it will produce toxic gases. The gas can be invisible and odourless; therefore, you should never operate the machine in an enclosed or poorly ventilated area.

- When trimming, ensure that the area is well lit. If you are trimming when it is raining, snowing or freezing on slopes, or on uneven terrain, make sure you have a stable position.
- Don't leave the machine unattended. Visitors and onlookers, especially children and the infirm, should be kept at a safe distance from your workplace. Make sure that other people cannot access an unattended machine.
- Ensure safe tool storage. Machines that are not in use should be stored in a dry place, high up if possible, or they should be locked away so that other people cannot gain access to them.
- Hedge trimmer transport. The hedge trimmer is transported with a blade protection cover. When not in use, replace this cover to prevent accidents. Secure the machine against tilting, damage and fuel leakage.
- Remove tool keys. Before switching the hedge trimmer on, remove all keys, etc.
- Always be careful and watch what you are doing.
When working, use common sense. Do not use machinery if you are tired. Do not use the hedge trimmer under the influence of alcohol, drugs or medicines that lower the ability to concentrate.
- Fuel replenishment. Before refuelling, switch off the engine. Carefully open the fuel cap so that excess pressure can escape slowly, and the fuel does not splash. The use of the trimmer results in high temperatures. Let the machine cool down before refuelling, otherwise the fuel could ignite, and people could get burnt. When refuelling, make sure the fuel tank is not over filled, to allow room for expansion. If the fuel leaks, it is important to wipe up any leaked fuel and clear the machine. After refuelling, ensure the fuel cap is sufficiently tight to prevent being loosened by the vibrations when the machine is in use.

- Usage period and breaks. After a longer period of usage, you might experience problems with blood circulation in your hands due to the vibrations. The period of usage can be extended by wearing suitable gloves and taking regular breaks. Please be aware that the time of usage is lowered by personal dispositions to bad circulation, a low outside temperature, or a firm grip of the tool when working.
- Watch for damaged parts. The machine should be carefully inspected before use. Are any of the parts damaged? In case of slight damage, consider if the machine is still going to work safely and without any problems. Make sure it is properly adjusted and movable parts are properly regulated. Are any elements interlocked improperly? Is everything well installed: Are all requirements for trouble-free operation fulfilled? Damaged protective devices, etc., must be repaired or replaced by the authorised service centres, unless expressly stated otherwise in the manual. Faulty switches should also be replaced in the authorised service centre. If you need to have your machine repaired, contact your nearest store.
- Make sure that the protective cover of the hedge trimmer works perfectly, and it is installed in such a way that the blade teeth are always covered.
- Before adjustments or machine maintenance, switch off the engine. This is valid mainly if the cutting blade is being replaced.
- Use only approved components. During maintenance and repairs, use only identical spare parts. Contact your authorised service centre for this purpose.



Caution! Using different cutting blades, and other fixtures and extensions that are expressly not recommended, can endanger people and property.



WARNING! The cutting blade can hurt your hands and fingers and cause life threatening injuries!

Always secure adequate lighting.

The manufacturer cannot be liable if the machine was modified or used unprofessionally, and damage arose as the result of these actions.

When handling the machine professionally, there is always some risk that cannot be eliminated. The machine type and construction might present the following potential risks:

- a) Contact with an unprotected cutting blade (danger of cutting yourself).
 - b) Touching the trimmer in operation (danger of cutting yourself).
 - c) Unexpected, sudden movements of the cut material and its parts (danger of cutting yourself).
 - d) Spurning of faulty blade teeth and parts of cutting blade (danger of cutting yourself).
 - e) Hearing injuries if appropriate safety aids are not worn.
 - f) Creation of harmful dust or gas when using the machine in closed premises (sickness).
 - g) Do not use deformed or damaged cutting blades (cutting blade destruction).
- Switch off the engine before you start adjusting or maintaining the machine.
 - Make this instruction manual available to everybody who is working with the machine.
 - Use this machine only for trimming hedges and foliage, and cutting wood, max. 27mm.
 - Do not use trimmers in the vicinity of flammable fluid or gas.
 - Have the machine repaired in an authorised service centre. Do not attempt to repair it yourself.

- Repairs and part replacements can be carried out only by an authorised service centre.
- Keep your workplace clean; remove trimmed waste and clear away objects you no longer require.
- Ensure a good foothold; be careful not to stumble in the vicinity of the trimmer.
- The person working with the machine should not get disturbed.
- Use only perfect cutting blades, e.g. well sharpened, without cracks, clinks, or deformations, etc.
- Faulty cutting blades should be replaced immediately.
- Never use cutting blades that do not correspond with technical data stated in this instruction manual.
- Make sure the cutting blade is installed in the right position.
- The machine's protective device cannot be disassembled or made dysfunctional in any way.
- Damaged or faulty protective devices should be replaced immediately.
- If you get disturbed when working with the trimmer, act with prudence until you adapt your attention to a new situation.
- At regular intervals, check all screws, nuts and fittings are tight enough.
- Never deposit tools or materials above the machine so that they could fall down on it.
- Make sure your hands are in the right positions, e.g. make sure they can not slide and suddenly come in contact with the cutting blade.
- The material you want to cut should not include nails or other similar foreign matters.
- Do not overload the machine so it does not slow down and get overheated.
- Never attempt to remove loose trimmings or wood fragments or jammed material when the machine is working.

- If you want to remove some defects or clean the machine of jammed pieces of wood, you must switch it off first.
- Machine adjustment, measuring, cleaning, etc., is allowed only when the engine is switched off.
- Do not leave an active engine unsupervised.
- After a repair or maintenance of safety or protective devices, the devices must be reinstalled correctly in the machine.
- It is essential to know the regulations regarding accident prevention that are valid in a specific workplace, and all other generally acknowledged safety regulations.
- When working, pay attention to stability and maintain good balance.
- Check the machine on a regular basis for signs of wear and damage.
- Before using the machine, you must check safety devices. Make sure that components that might seem slightly worn or damaged still perform correctly.
- Check if all movable parts work perfectly. Concentrate mainly on the damaged and jammed components.
All components must be installed properly and must comply with conditions for trouble-free operation.
- Unless stated otherwise in the instruction manual, the damaged components and safety devices should be repaired or replaced in an authorised service centre.
- Damaged switches should also be replaced in an authorised service centre.
- The machine complies with all relevant safety provisions. Repairs can be carried out only by qualified repair staff in authorised centres using original spare parts. In case of non-compliance with the provision, there is a danger of accident.

- Do not use the hedge trimmer if your concentration is lowered, after taking medication, or if you are under the influence of alcohol, or are tired.
- The machine can be used only for the intended purpose. Any machine usage at variance with its intended purpose is considered unprofessional usage.
- The user is liable for the damage caused to property and injuries resulting from this unprofessional handling, and not the manufacturer.

PRODUCT DESCRIPTION AND IDENTIFICATIONS

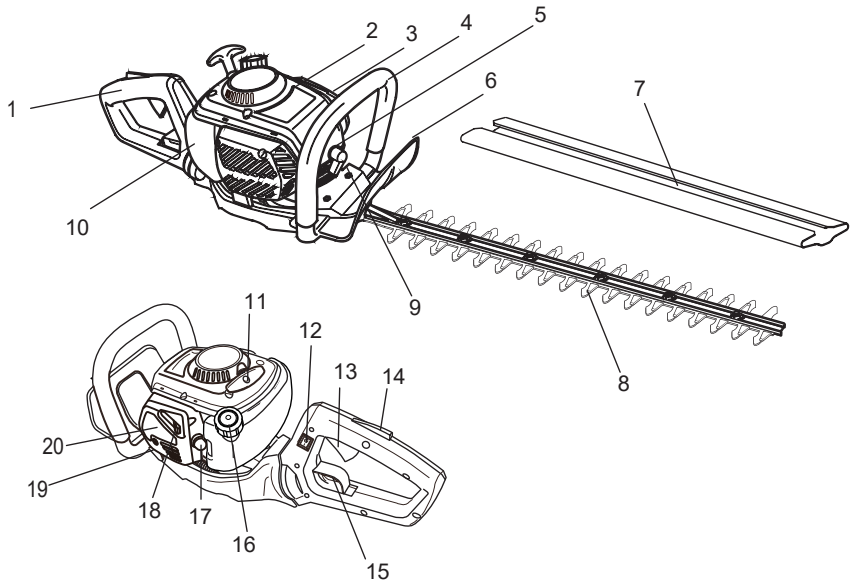

- | | | | |
|----|----------------------|----|-------------------------|
| 1 | Handle | 11 | Recoil starter handle |
| 2 | Motor housing | 12 | Ignition switch |
| 3 | Exhaust outlet | 13 | Throttle trigger |
| 4 | Front handle | 14 | Throttle interlock |
| 5 | Spark plug | 15 | Unlock lever |
| 6 | Front guard | 16 | Fuel tank cap |
| 7 | Blade cover | 17 | Primer |
| 8 | Cutting device | 18 | Chock lever |
| 9 | Spark plug connector | 19 | Air filter fixing screw |
| 10 | Fuel tank | 20 | Air filter cover |

Not all the accessories illustrated or described are included in standard delivery.

ASSEMBLY AND USE



WARNING! Depending on the actual use of the product the vibration values can differ from the declared total! Adopt proper measures to protect yourself against vibration exposures! Take the whole work process including times the product is running under no load or switched off into consideration!

Proper measures include among others regular maintenance and care of the product and cutting attachments, keeping hands warm, periodical breaks and proper planning of work processes!

INTENDED USE

This petrol hedge trimmer is designated with an engine displacement of 26 cm³. The product is intended for trimming hedges, bushes and shrubs. Observe the technical data for the maximum cutting capacity. Do not cut branches exceeding the stated maximum capacity.

For safety reasons it is essential to read the entire instruction manual before first operation and to observe all the instructions therein.

This product is intended for private domestic use only, not for any commercial trade use. It must not be used for any purposes other than those described.

Assembly instructions



WARNING! Before using the product, familiarise yourself with the operating features read the entire instruction manual paying particular attention to the safety rules and operating procedures.

UNPACKING

1. Unpack all parts and lay them on a flat, stable surface.
2. Remove all packing materials and shipping devices if applicable.
3. Make sure the delivery contents are complete and free of any damage. If you find that parts are missing or show damage do not use the product but contact your dealer. Using an incomplete or damaged product represents a hazard to people and property.
4. Ensure that you have all the accessories and tools needed for assembly and operation. This also includes suitable personal protective equipment.

BLADE COVER

1. Remove the blade cover (7) from the cutting device (8) before operation (Fig. 1).

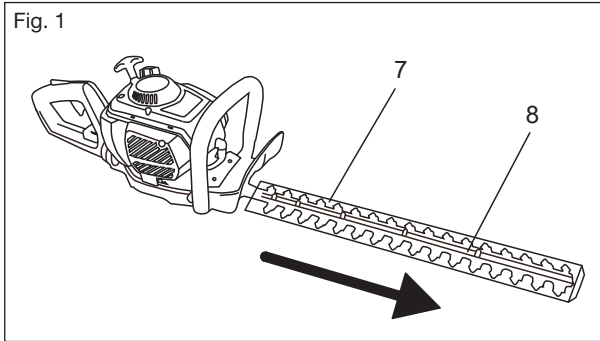

NOTE: Always attach the blade cover (7) when the product is not in use, for and transportation.

To attach the blade cover, align and push the blade cover onto the cutting device (8).

HANDLE ADJUSTMENT

Adjust the handle to fit the application.

1. Pull the unlock lever (15) backward and hold it in position (Fig. 2).

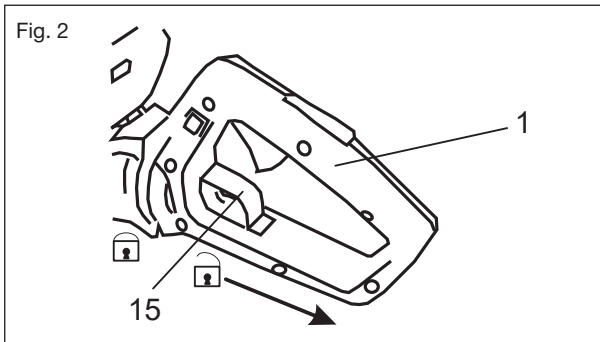

2. Adjust the handle (1) to required position and release the unlock lever (15). Keep turning the handle until it snaps securely into place (Fig. 3-6).

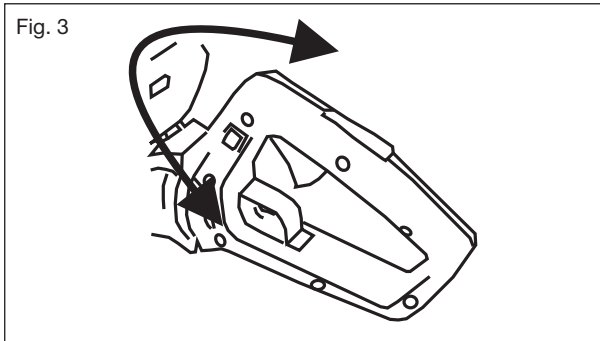

WARNING! Only adjust the handle position when the engine is switched off!
Always ensure that the handle locks in one of the end positions, never use it in any intermediate position!

Fig. 4

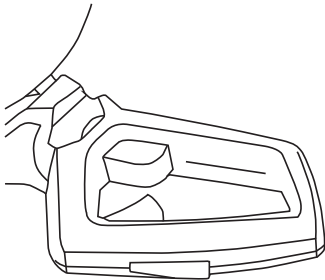

left position (-90°)

Fig. 5

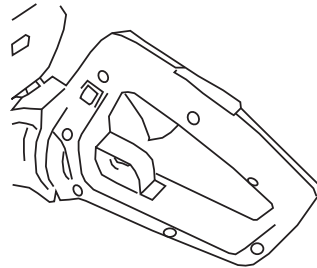

initial position (0°)

Fig. 6

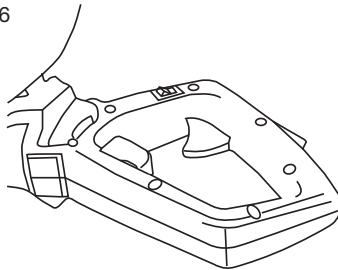

right position (90°)

FUEL AND ENGINE OIL



NOTE: This product is not supplied with fuel-oil mixture in the engine! Before operating this product it is essential to fill it with fuel-oil mixture!

This product is equipped with a 2-stroke engine, the fuel and oil tank are combined and it is essential to fill a fuel-oil mixture before operating this product. Observe the technical specifications for suitable fuel and engine oil.



WARNING!



Fuel and oil are highly inflammable! Fumes will explode if lit! Ensure that there are no naked flames around the product! Do not smoke while filling fuel and oil!



1. Place the product on a stable, level surface. We recommend laying a non-flammable sheet under the product.
2. Mix a regular-grade unleaded petrol and a quality engine oil for air cooled 2-stroke engines in a suitable container (Fig. 7).

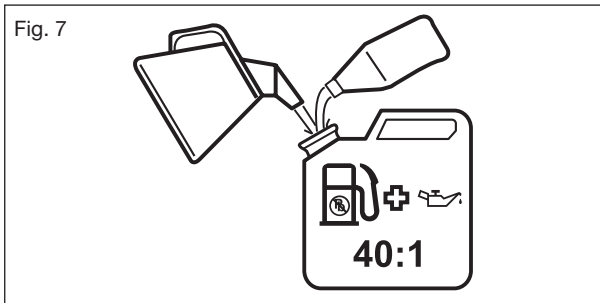

Fill half the quantity of the petrol to be used into the container. Then add the entire quantity of oil and shake the prepared fuel mixture. Add the remaining quantity of petrol. Shake the fuel mixture thoroughly before filling the fuel tank.

3. Use an anti-oxidant added quality oil expressly labelled for air-cooled 2 stroke engine use (JASO FC GRADE OIL or ISO EGC GRADE).
4. Do not use BIA or TWC (2 stroke water-cooling type) mixed oil.
5. The recommended mixing ratio for petrol:oil is 40:1.



NOTE: Never mix fuel and oil directly in the tank of the product. Use a fuel mixing container that helps to ensure the correct mixing ratio. Shake gently to ensure a thorough mix of fuel and oil.

6. Unscrew and remove the fuel tank cap (16).

7. Fill correctly mixed fuel/oil into the tank using a fuel funnel fitted with a filter to avoid debris entering the tank. Do not overfill. Leave a minimum 5 mm of space between the top of the fuel and the inside edge of the tank (10) to allow for expansion (Fig. 8).

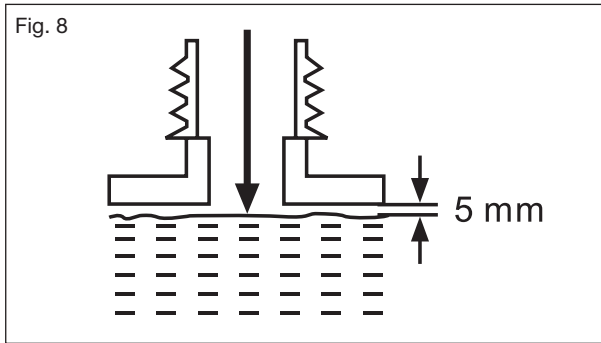

8. Avoid spilling and overfilling the tank.
9. Wipe up spilled fuel with a soft cloth and refit the fuel tank cap (16).
10. Always dispose of fuel, used oil and soiled objects according to local regulations (see section "Recycling and disposal").



NOTE: Fuel and oil deteriorate over time. It may be difficult to start the engine if you use fuel which has been kept for more than 30 days.



Towards the end of the season, it is advisable to put only as much fuel in the tank as you need for each use, since it should be completely used up before storing the product.

Empty remaining fuel from the tank when storing the product for over 30 days.

HANDLE CONTROLS

There are three controls at the handle (1) with the following function:

1. The ignition switch (12) electrically stops the engine. Before you start the engine, you always need to put the ignition switch (12) to the "I" position.
2. The throttle interlock (14) prevents unintentional activation of the throttle trigger (13) until manually pressed.
3. Adjust the engine speed with the throttle trigger (13).



NOTE: The throttle trigger will not work if the unlock lever (15) did not snap securely into place.

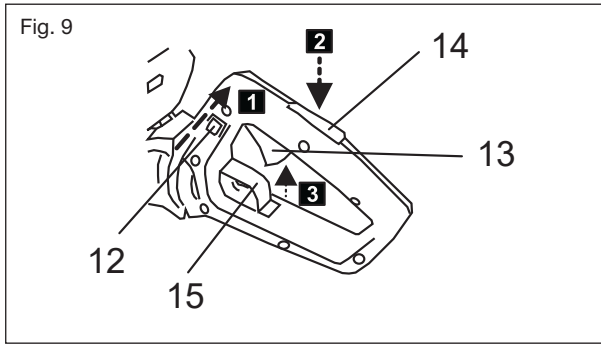

Operating instructions

GENERAL OPERATION

1. Check the product as well as accessories for damage before each use. Do not use the product if it is damaged or shows wear.
2. Double check that accessories or cutting device are properly fixed.
3. Always hold the product on its handles (3,5). Keep the handles dry to ensure safe support.
4. Ensure that the air vents (21) are always unobstructed and clear. Clean them if necessary with a soft brush. Blocked air vents may lead to overheating and damage to the product.
5. Switch the product off immediately if you are disturbed while working by other people entering the working area. Always let the product come to a complete stop before putting it down.
6. Do not overwork yourself. Take regular breaks to ensure you can concentrate on the work and have full control over the product.

TRIMMING TIMES

green leaf hedges	June to October
evergreens	April and August
conifers and other fast growing	every 6 - 8 weeks

STARTING/STOPPING

Cold start (Fig.10, 11)



WARNING! Make sure that the cutting device is not touching the ground or other objects when starting the product!

Make sure that the rear handle is in the upright position.

1. Place the product on level ground and ensure that no objects or obstructions could come in contact with the blades.
2. Set ignition switch (12) to "I" (ON) position.
3. Press the primer (17) 5-6 times.
4. Move the choke lever (18) to "  start" position.
5. Hold the top cover firmly with your left hand and put your right knee onto the rear handle (1).
6. Pull the recoil starter handle (11) lightly until you feel resistance, then pull it briskly 3-4 times. The engine would normally not start at this stage.

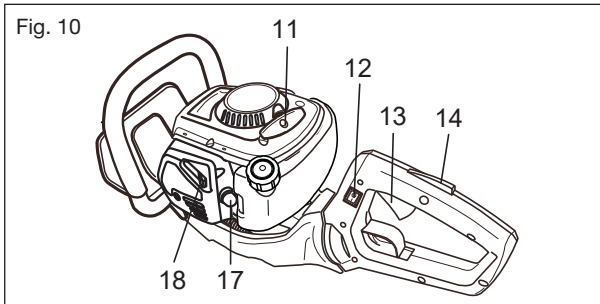

WARNING! Allow the rope to return slowly and in a controlled manner each time it is pulled!

7. Move the choke lever (18) to "  Run" position. Pull the starter handle to start the engine. If it can not start, move on to the next steps. Squeeze the throttle interlock (14) and the throttle trigger (13) 2-3 times, then pull the recoil starter handle (11) to start motor.

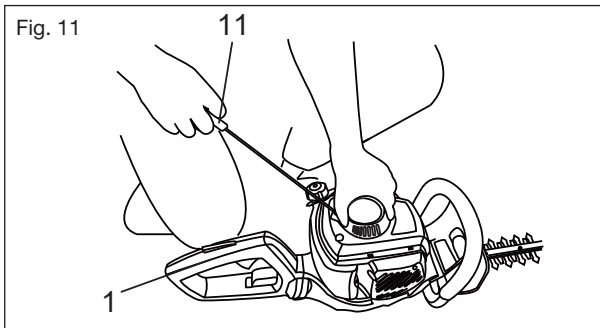

Warm start (Fig.12, 13)



WARNING! Make sure that the cutting device is not touching the ground or other objects when starting the product!

1. Set the ignition switch (12) to "I" (ON) position.
2. Do not press the primer (17).
3. Move the choke lever (18) to "  Run" position.
4. Hold the top cover firmly with your left hand and put your right knee onto the rear handle (1).
5. Pull the recoil starter handle (11) lightly until you feel resistance, then pull it briskly 1-2 times.
Do it again until the engine starts.

Fig. 12

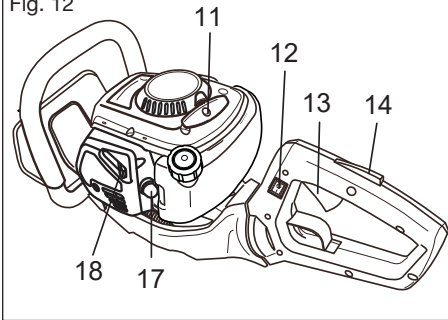
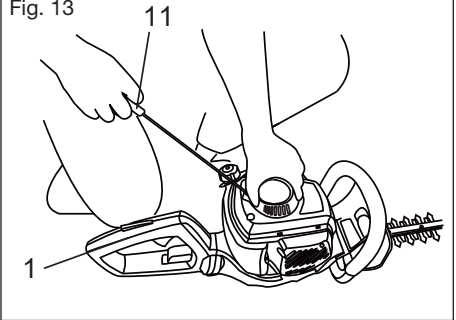

Fig. 13



WARNING! Allow the rope to return slowly and in a controlled manner each time it is pulled!



NOTE: If the engine does not start, the engine may be flooded. Flooding is caused by too much fuel mixture applied at the wrong time and can prevent a product from starting. DO NOT prime the product again. Follow below procedure:

Set the ignition switch (12) to "STOP" (OFF) position. Squeeze the throttle interlock (14) and throttle trigger (13) to release the choke. Remove the spark plug (see "Maintenance and care - Spark plug"). Dry the spark plug. Slowly pull the recoil starter handle (11) for several times to drain the fuel from the combustion chamber. Refit the spark plug. Clean up any spilled fuel and move the product at least 3 metres (10') away before starting the engine. Start the product as described in section "Warm start".

Stopping

1. Release the throttle trigger (13) and let the product run at its idle speed for 10 - 15 seconds.
2. Set the ignition switch (12) to its "STOP" (OFF) position (Fig. 14).

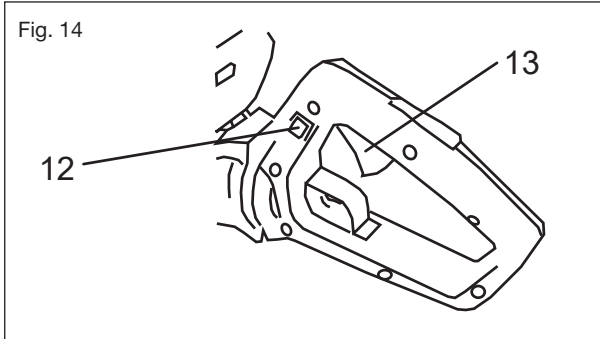

WARNING! The cutting device will continue to run for some time even after the engine has been switched off! Wait until the cutting device has come to a complete stop before placing the product on the ground!

TRIMMING



NOTE: Try to keep the cutting device angled at approximately 15° to the cutting surface.

1. Cut and remove branches exceeding the cutting capacity of this product using a proper pruner before operation.
2. Adjust the handle so that it fits the intended cut.

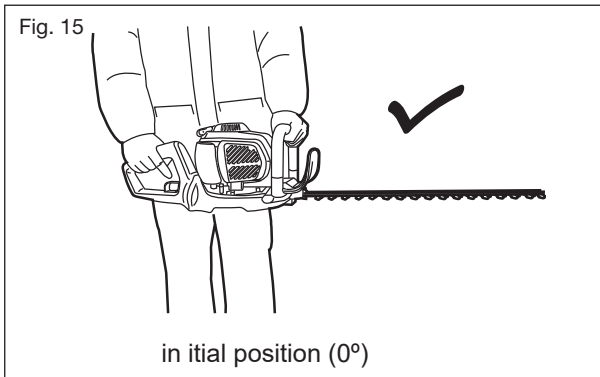



WARNING! When operating the product, keep the exhaust outlet (20) away from your body (Fig. 15-20).

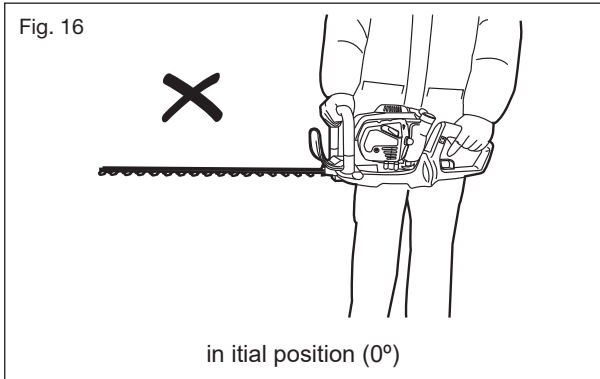

3. Start the product as described. Press the throttle interlock, hold it in position and then press the throttle trigger to engage the cutting blade. Operate the engine at full throttle to maintain a proper cutting speed.
4. Move the cutting device lightly through the cutting surface in a sweeping motion following the shape of the hedge or shrub. A slight tilt downwards of the cutting device in the direction of motion is recommended for optimum cutting performance.
5. Do not to rush and do not attempt to cut too much with one stroke of the cutting device.

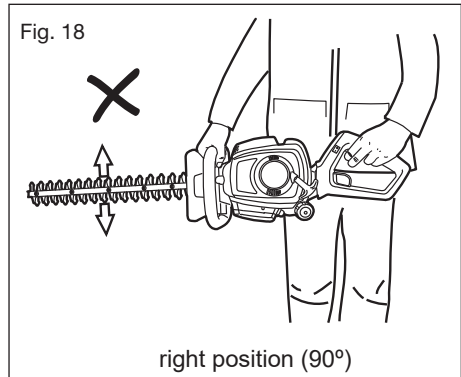
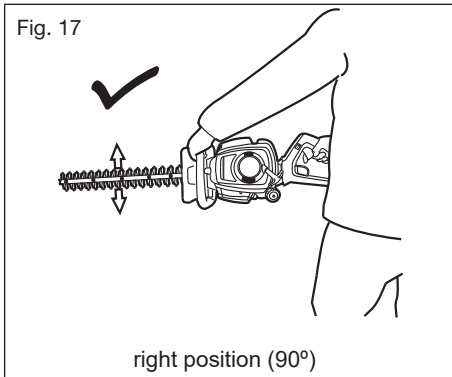

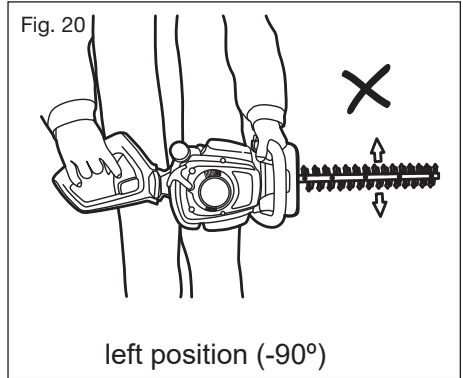
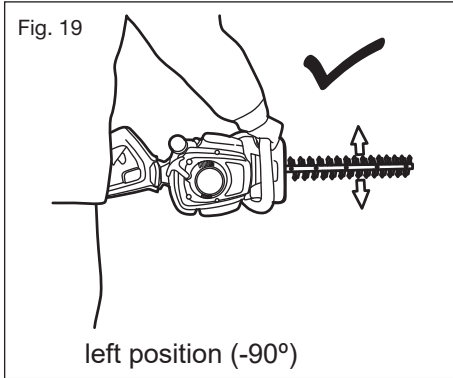

6. First cut both sides from the bottom cutting upwards to the top. This will prevent any of the trimmings falling into the path of the area still to be cut (Fig. 21).

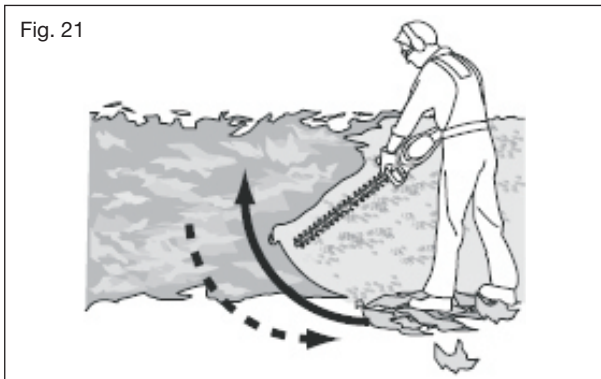

7. After cutting the sides proceed to the top (Fig. 22). Try to keep the cutting device angled at approximately 15° to the cutting surface.

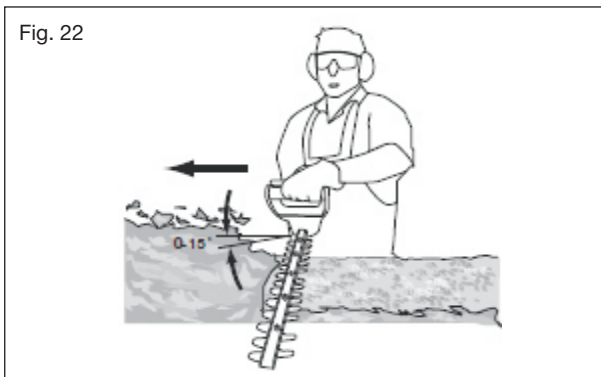

- Cut in a number of stages if the area being cut is particularly long to achieve a better result; smaller trimmings will allow for easy composting.

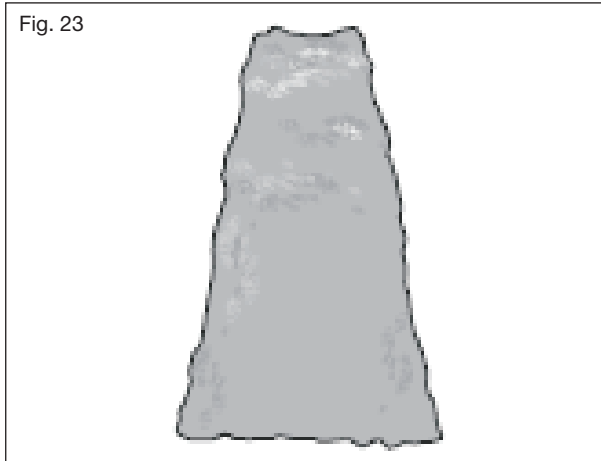

NOTE: When shaping it is advisable to achieve a trapezoidal shape (Fig. 23). A trapezoidal cut corresponds to the natural growth of plants and results in optimal hedge growth, as it will expose more light to the lower end of the hedge.



WARNING! TO STOP THE ENGINE IN AN EMERGENCY:

Press and hold the ignition switch (10) to “STOP” position until engine stops.

AFTER USE

- Switch the product off, allow the engine to cool down and then remove the spark plug connector.
- Check, clean and store the product as described below.

CARE AND CLEANING

MAINTENANCE AND CARE



WARNING! Always switch the product off, let the product cool down and disconnect the spark plug connector before performing inspection, maintenance and cleaning work!

1. Keep the product clean. Remove debris from it after each use and before storage.
2. Regular and proper cleaning will help ensure safe use and prolong the life of the product.
3. Inspect the product before each use for worn and damaged parts. Do not operate it if you find broken and worn parts.



WARNING! Only perform repairs and maintenance work according to these instructions! All further works must be performed by a qualified specialist!

GENERAL CLEANING

1. Clean the product with a damp cloth and mild soap. Use a brush for areas that are hard to reach.
2. In particular clean the air vents (21) after every use with a cloth and brush.
3. Remove stubborn dirt with high pressure air (max. 3 bar).



NOTE: Do not use chemical, alkaline, abrasive or other aggressive detergents or disinfectants to clean this product as they might be harmful to its surfaces.

4. Check for any damage and wear. Repair damages in accordance with this instruction manual or take it to an authorised service centre before using the product again.

Cutting device



WARNING! Wear safety gloves when working on the cutting device and close to it! Use appropriate tools to remove debris, e.g. a brush or wooden stick! Never use your bare hands!



The replacement of the cutting device should be done by a qualified specialist!

Rework or sharpening blades is not recommended unless it is done by a repair service or a similarly qualified specialist!

1. Keep the cutting device (8) clean and free of debris. Remove trimmings.
2. Apply a small amount of suitable lubricant on the cutting device (8) to retain a good cutting performance (Fig. 24).

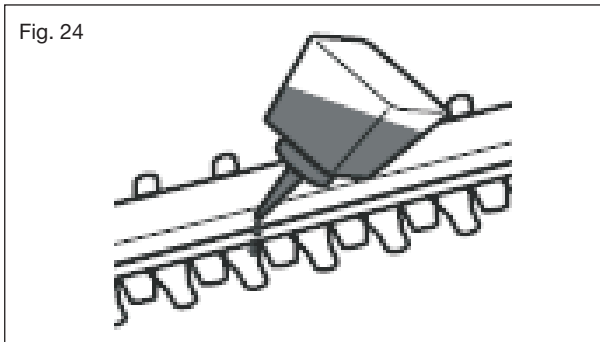

3. Keep the cutting device (8) sharp. Have a worn or damaged cutting device replaced with a new one of the same type by a qualified specialist.
4. Tighten loose nuts on the cutting device (8) with a proper wrench with 5 N.m min, 7 N.m max. to ensure safe operation of your product (Fig. 25).

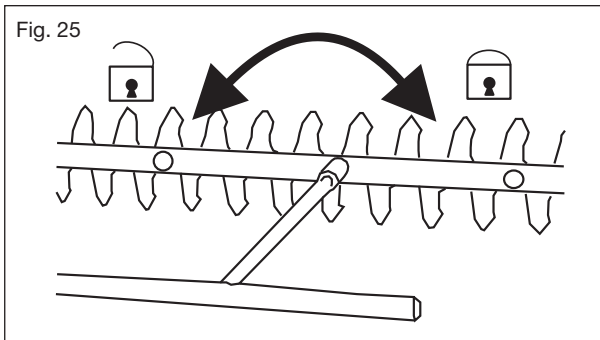

AIR FILTER

1. Inspect the air filter regularly. Replace it with a new one if necessary.
2. Open the air filter case by loosening the fixing screw with the socket wrench/cross head screw-driver.
3. Remove the screw, cover (20) and take the filter (20a) out (Fig. 26).

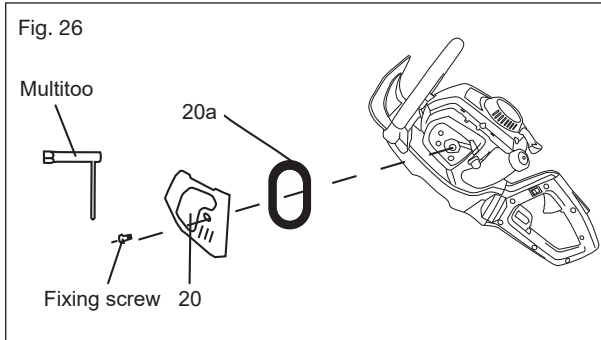

4. Tap the filter on a stable surface to remove dust. Use compressed air (max. 3 bar) to remove stubborn dust.
5. Apply a small amount of air filter oil on the filter to increase the performance of the filter. Wring out surplus oil and put the filter into the case.
6. Put the air filter cover (20) back in place and fix it with the screw.

FUEL TANK

1. Empty the fuel tank when storing the product over 30 days to prevent the fuel from deteriorating.
2. Unscrew and remove the fuel tank cap (16) and use a proper fuel pump to empty the fuel into a suitable container.

FUEL FILTER

The fuel tank (10) of this product is fitted with a filter located at the free end of the fuel pipe.

Ask an authorised service centre or similar qualified person to check and where necessary replace it at regular intervals.

SPARK PLUG

1. Inspect the spark plug (5) at least every 25 hours or prior to long-term storage over 30 days if the use has not been this high. Clean or replace with a new spark plug if necessary, refer to section "TECHNICAL SPECIFICATIONS".

2. Unplug the spark plug connector (9) (Fig. 27).

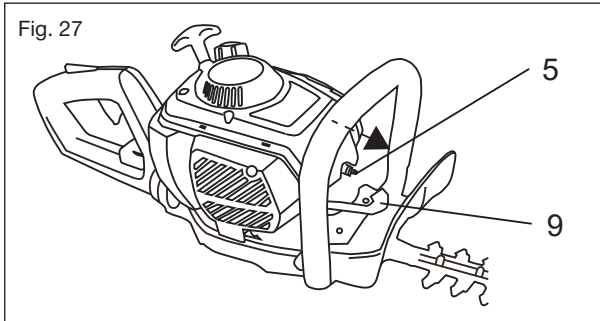

3. Loosen the spark plug with the socket wrench/cross head screw-driver anticlockwise and carefully remove it (Fig. 28).

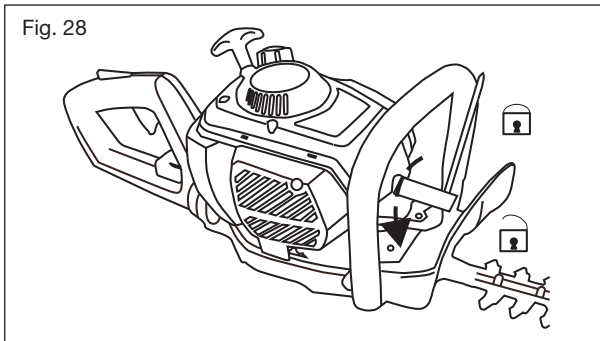

4. Check the spark plug (5) for damage and wear. The colour of the electrode should be light brown coloured.
5. Remove debris from the electrode with a soft wired brush; avoid heavy cleaning of the electrode.
6. Dry the spark plug (5) with a soft cloth if it is wet from fuel.
7. Check the spark plug gap; it should be 0.6 – 0.7 mm (Fig. 29).

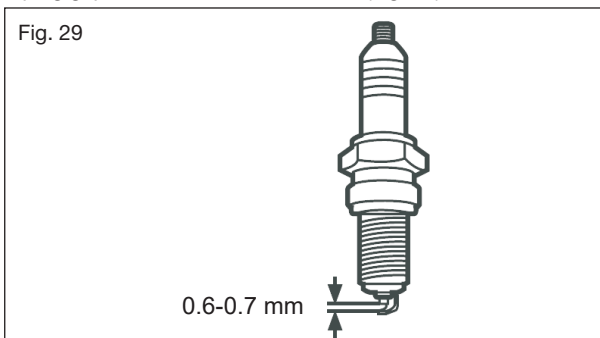

8. Replace with a new spark plug (5) if either the electrode or the insulation is damaged.
9. When replacing the spark plug (5) first screw it in hand tight and then lightly tighten it with the socket wrench/cross head screw-driver.

GEAR BOX

1. Lubricate the gear box every 30 hours or more frequent at heavy use.
2. Add grease through the lubricator (23) with an lubricating gun until the grease comes out between the gear box (22) and the cutting device (8) (Fig. 30).
3. Remove any grease from the product.

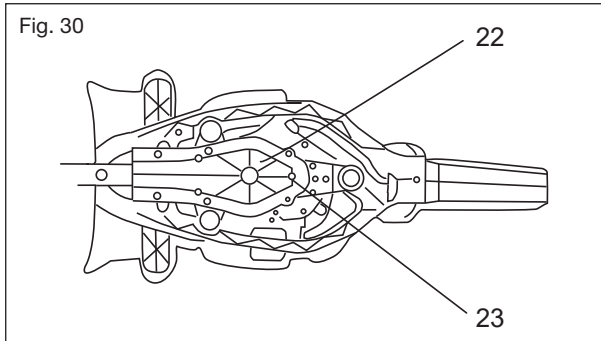

CARBURETTOR

The carburettor is pre-set by the manufacturer. Should it be necessary to make any changes please contact an authorised service centre or a similarly qualified person. Do not attempt to make any adjustments by yourself.

REPAIR

This product does not contain any parts that can be repaired by the consumer. Contact an authorised service centre or a similarly qualified person to have it checked and repaired.

MAINTENANCE TABLE

Part	To do	Before/after each use	10 hours	25 hours	50 hours / half year	100 hours / once a year
Spark plug	check			x		
Spark plug	clean			x		
Spark plug	replace	whenever necessary				
Air filter	check	x				
Air filter	clean			x		
Air filter	replace	whenever necessary				
Fuel filter	check			x		
Fuel filter	clean			x		
Fuel filter	replace	whenever necessary				
Cutting blade	check	x				
Cutting blade	lubricate	x				
Cutting blade	clean	x				
Cutting blade	replace	whenever necessary				

STORAGE

1. Drain all fuel from tank into a container. Run engine until it stops. Always drain the fuel tank outdoors.
2. Switch the product off and disconnect the spark plug connector.
3. Clean the product as described above.
4. Attach the blade cover.
5. Store the product and its accessories in a dry, frost-free place.
6. Always store the product in a place that is inaccessible to children. The ideal storage temperature is between 10 and 30°C.
7. We recommend using the original package for storage or covering the product with a suitable cloth or enclosure to protect it against dust.

TRANSPORTATION

1. Switch the product off and disconnect the spark plug connector.
2. Attach the blade cover.
3. Always carry the product by its handles.
4. Protect the product from any heavy impact or strong vibrations which may occur during transportation in vehicles.
5. Secure the product to prevent it from slipping or falling over.

RECYCLING AND DISPOSAL

1. The product comes in a package that protects it against damage during shipping. Keep the package until you are sure that all parts have been delivered and the product is function properly. Recycle the package afterwards.
2. Old products are potentially recyclable and do not, therefore, belong in your household rubbish. You are requested to assist us and our contribution to saving resources and protecting the environment by handing in this product at an equipped collection centre (if there is one available).
3. Petrol, oil, used oil, mixtures of oil and petrol and objects contaminated with those, e.g. cleaning cloths; do not belong with household waste. Dispose of oil-contaminated items in accordance with the local guidelines and hand them in at recycling centres.

TROUBLE SHOOTING



CAUTION!

- Always switch off the engine and pull the ignition cable before starting any inspection or adjustment work.

- Remember that the exhaust and other parts will get hot after running the engine, even if only for a few minutes.

The following table provides solutions to common problems encountered with the hedge trimmer.

Fault	Possible Cause	Solution
Engine not starting	<ol style="list-style-type: none"> 1. Empty tank 2. Flooded engine 3. Fouled spark plug (remains of carbon on the electrodes) 4. Electrode gap too large 5. Fouled carburettor or its jets 6. Damaged spark plug connection or damaged spark plug 	<ol style="list-style-type: none"> 1. Fill up 2. Close the throttle, pull cord several times. If required, take out the spark plug and dry it 3. Clean the spark plug, check its temperature, replace if needed 4. Adjust at 0.6-0.7mm 5. Clean the carburettor with air 6. Replace the spark plug
Engine runs too fast when idle	<ol style="list-style-type: none"> 1. Cold engine 	<ol style="list-style-type: none"> 1. Warm up slowly; alternatively, close the choke a bit
Engine does not reach its maximum speed.	<ol style="list-style-type: none"> 1. Fouled spark plug (remains of carbon on the electrodes) spark gap to large 2. Fouled carburettor or its jets 3. Fouled air filter 4. Exhaust, exhaust channel 5. Sealing ring in crankcase not sealing properly 6. Worn cylinders, pistons and piston rings 7. Wrong fuel mix (too much oil) 8. Bad ignition 	<ol style="list-style-type: none"> 1. Clean the spark plug, check its temperature, replace if needed. Adjust at 0.6-0.7mm 2. Clean the carburettor with air 3. Clean 4. Take out the exhaust and clean it, remove remains of carbon 5. Replace 6. Replace the cylinder, piston or piston rings, replace the cylinder and piston, assembly 7. Fill up according to the instructions 8. Adjust the ignition coil gap (0.3-0.4mm)
Engine would not stop	<ol style="list-style-type: none"> 1. The switch has failed 2. The wiring terminal was disconnected 	<ol style="list-style-type: none"> 1. Change the switch 2. Connect up the wiring terminal

MAINTAINANCE AND STORAGE

LIST OF VULNERABLE PARTS

Description	Models or specification
Spark plug	BBCH011001
Air filter	BBCH011144
Fuel filter	BBCH011131

DECLARATION OF CONFORMITY / PERFORMANCE



Product Code: 90364/SLK26B-1

Product Description: Hawksmoor 26cc Petrol Hedge Trimmer

1. Toolstation (company number 04372131)

This declaration of conformity is issued under the sole responsibility of Toolstation

2. Object of the declaration

The object of the declaration described above is in conformity with the relevant Community harmonization legislation:

Supply of Machinery (Safety) Regulations 2008

2006/42/EC

Electromagnetic Compatibility Regulations 2016

2014/30/EU

The Restriction of the Use of Certain Hazardous Substances in Electrical and Electronic Equipment Regulations 2012

2011/65/EU&(EU)2015/863

Noise Emission in the Environment by Equipment for use Outdoors Regulations 2001

2000/14/EC amended by 2005/88/EC:

- Conformity Assessment Procedure as per	Annex V
- Measured Sound Power Level	105.6 dB(A)
- Declared Guaranteed Sound Power Level	108 dB(A)

3. References to the relevant standards used (or references to the specifications in relation to which conformity is declared:

BS EN ISO 10517, BS EN ISO 14982

4. Additional information:

Signed for and on behalf of Toolstation Limited

ENVIRONMENTAL INFORMATION

Old products are potentially recyclable and do not, therefore, belong in your household rubbish. You are requested to assist us and our contribution to saving resources and protecting the environment by handing in this product at an equipped collection centre (if there is one available).

Petrol, oil, used oil, a mixture of oil and petrol and objects soiled with oil e. g. cleaning cloths do not belong in the household rubbish. Dispose of oil-contaminated items in accordance with the local guidelines and hand them in at recycling centres.

The product comes in a package that protects it against damage during shipping. Keep the package until you are sure that all parts have been delivered and the product is function properly. Recycle the package afterwards.

GUARANTEE

Toolstation products deliver reliable service for normal, household use in domestic settings. All Toolstation products are individually tested before leaving the factory.

If you are a consumer and you experience a problem with your Toolstation product, which is found to be defective due to faulty materials or workmanship within the Guarantee Period, this Toolstation Guarantee will cover repair or - at the discretion of Toolstation – replacement with a functionally equivalent Toolstation product.

Your product is under guarantee for 2 year from the date of purchase or the date of delivery of the product, if later.

The guarantee is subject to the following provisions:

- The guarantee does not cover accidental damage, misuse, cabinet parts, knobs, or consumable items.
- The product must be correctly installed and operated in accordance with the instructions contained in this manual.
- It must be used solely for domestic purpose.
- The guarantee will be retendered invalid if the product is re-sold or has been damaged by inexpert repair.
- Specifications are subject to change without notice.
- The manufacturer disclaims any liability for the incidental or consequential damages.
- The guarantee is in addition to, and does not diminish your statutory or legal rights.

CUSTOMER SUPPORT

www.coreservice.co.uk

Call us +44 01904 947568

Email: support@coreservice.co.uk

Made in China